

Quick Start Guide 快速操作指南

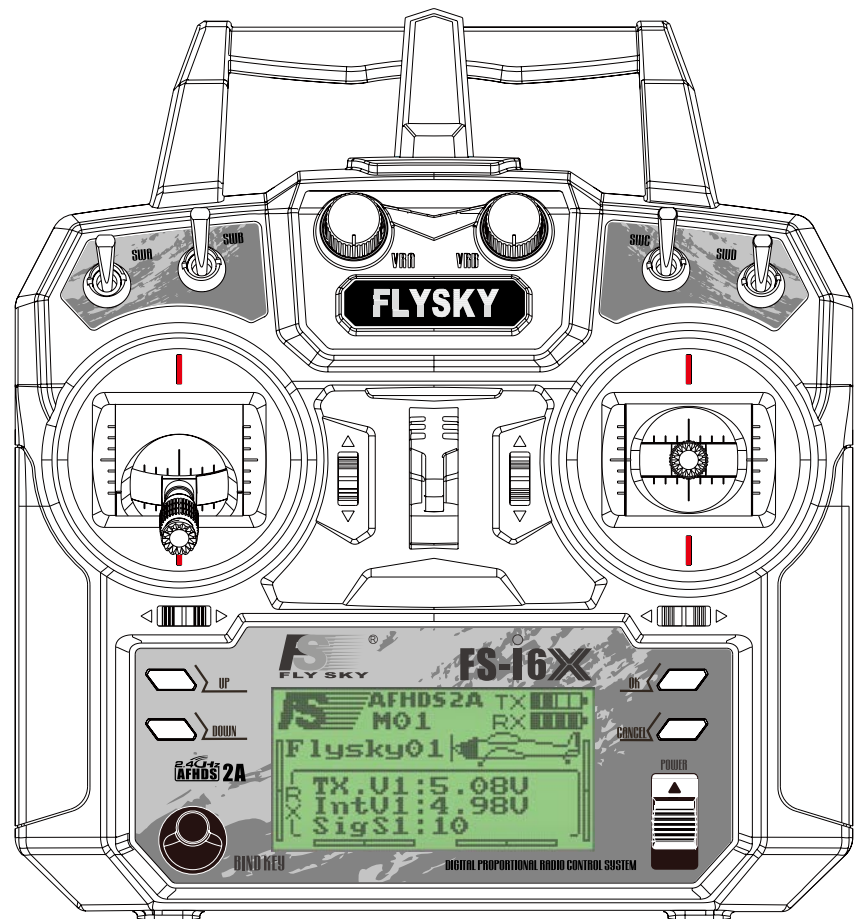

感谢您购买我们公司的产品！欲知更多产品信息，请浏览以下官方网站：www.flysky-cn.com。如果您在使用中遇到任何问题，请先查阅发射机帮助菜单或使用说明书。如果问题仍未得到解决，请直接联系当地经销商或者联系客服人员：flyskycr@flysky-cn.net

注意事项！

开始操作前请务必阅读以下安全信息！

- 请不要在夜晚或雷雨天气使用本产品，恶劣的天气环境有可能导致遥控设备失灵。
- 请不要在能见度有限的情况下使用本产品。
- 请不要在雨雪或有水的地方使用本产品。如果有液体进入到系统内部，可能会导致运行不稳定或设备失灵。
- 信号干扰可能导致设备失控。为保证您和他人的安全，请不要在以下地点使用本产品：



基站附近或其他无线活跃的地方



人多的地方或道路附近



有客船的水域

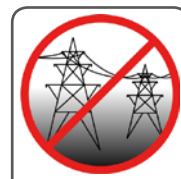

高压电线或通信广播天线附近

- 当你感到疲倦、不舒服，或在摄入酒精或导致麻醉或兴奋的药物后，不要操作本产品，否则可能对自己或他人造成严重的伤害。
- 2.4GHz 无线电波段完全不同于之前所使用的低频无线电波段。使用时请确保模型产品在您的视线范围内飞行，大的障碍物将会阻断无线电频率信号从而导致遥控失灵模型失控。
- 在使用过程中，严禁紧握发射机天线，否则将会大大减弱无线电传播信号的质量和强度，导致遥控失灵模型失控。
- 在操作或使用模型后，请勿触摸任何可能发热的部位，如发动机、电机、定速设定等。这些部件可能非常热，容易造成严重的烧伤。
- 遥控设备使用不当可能导致操作者或他人严重受伤，甚至死亡。为保证您和设备的安全，请仔细阅读使用说明书并按照要求进行操作。
- 使用前必须确保本产品与模型安装正确，否则可能导致模型发生严重损坏。
- 关闭时，请务必先关闭接收机电源，然后关闭发射机。如果关闭发射机电源时接收机仍然在工作，将有可能导致遥控设备失控或者引擎继续工作而引发事故。
- 操控时，请先确认模型所有舵机的动作方向与操控方向一致。如果不一致，请调整好正确的方向。
- 当遥控距离持续较远时，有发生失控的可能。请适当缩短遥控的距离。
- 仅使用厂家指定的电池。
- 请勿打开、拆卸或自行维修电池。
- 请勿挤压、刺穿电池或接触电池的金属部件。
- 请勿将电池置于高温环境或液体中。
- 请注意防止电池跌落、碰撞或振动。
- 请将电池存放在干燥阴凉的环境中。
- 如果电池损坏，请立即停止使用。

发射机概览

▶ 前视图：

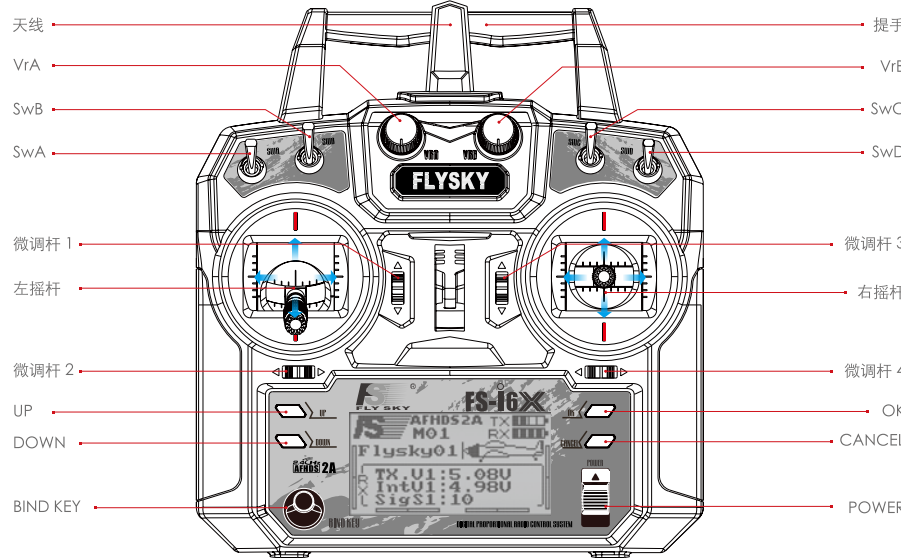

▶ 后视图：

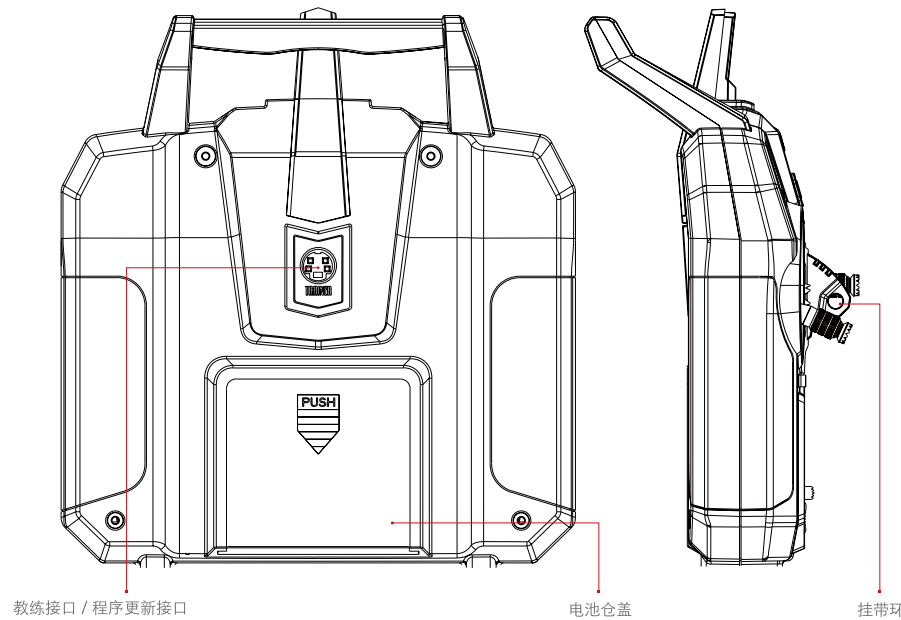

基本操作

▶ 电池安装

1. 打开电池仓盖。
2. 将 4 个充满的 AA 电池装入电池仓内，确保电池上的金属端子与电池仓内的金属端子相接。
3. 盖好电池仓盖。

▶ 开机

1. 检查系统状态，确保电池有电，以及接收机未开机并且安装正确。
2. 确保所有开关都处于最上端位置，油门摇杆处于最低端位置。
3. 向上拨动“POWER”开关，当发射机显示屏显示主界面时，表示已开机。
4. 为接收机连接电源。

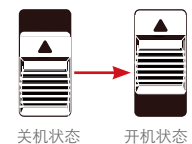

⚠ 如果有开关未拨动到最高档位或油门摇杆没有打到最低位置，系统会弹出“Place all switches in their up position and lower the throttle”的提示，按照要求检查并将开关或摇杆调整到正确位置后方可正常开启发射机。

⚠ 如油门处于安全位置，发射机依然无法开启，请检查您的发射机开关是否安装，或长按“OK”键进入 [Aux. switches] 菜单中关闭未安装的开关。

▶ 对码

本发射机和接收机在出厂前已对码成功。如果您要使用其他的发射机或接收机，请按照如下步骤进行对码：

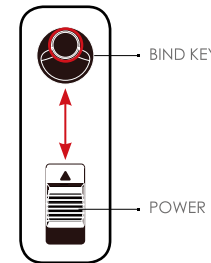

1. 将对码线连接到接收机上的 B/VCC 接口。
2. 将电源线连接到接收机上任意其他接口。
3. 按下发射机“BIND”按键，同时打开发射机电源进入对码状态，发射机显示“RX binding.....”。
- 对码成功后，发射机提示“RX bind ok”后，自动退出对码界面。
4. 将对码线和电源从接收机上断开，然后重新将电源线连接到 B/VCC 接口。
5. 检查发射机、接收机、模型是否正常工作。如有异常，重复以上步骤重新对码。

▶ 关机

1. 断开接收机电源。
2. 将发射机“POWER”键向下拨动，发射机显示屏黑屏后表示发射机电源关闭。
- ⚠ 关闭前，请务必先断开接收机电源，然后关闭发射机。如果强行关闭发射机，将有可能导致遥控设备失控或者引擎继续工作而引发事故。

规格参数

通道个数	6-10 (默认 6)
适用机型	固定翼 / 滑翔机 / 直升机
频率范围	2.408-2.475GHz
发射功率	不高于 20dBm
波段个数	135
波段宽度	500KHz
2.4GHz 模式	第二代增强型自动跳频数字系统 (含第一代系统)
调制方式	GFSK
摇杆分辨率	4096 级
低电压报警	低于 4.2V
数据输出	PS/2 接口
充电接口	无
天线长度	26mm(双天线)
机身重量	392g
输入电源	6V DC 1.5AA*4
显示方式	STN 半透正显 ,LCD128x64 点阵, VA 73x 39mm, LCD 白色背光
外形尺寸	174mm×89mm×190mm
在线更新	有
外形颜色	黑色
认证	CE, FCC ID:N4ZFLYSKYI6X



Thank you for purchasing our product! To find out more about our products, visit our website at www.flysky-cn.com. If you encounter any problem during use, refer to the transmitter's on-board help files or instruction manual first. If the problem persists, contact your local dealer or visit our service for help: flyskycn@flysky-cn.net

Precautions !

Read the safety messages listed below before operation!

Do not use the product at night or during bad weather conditions, like rain or thunderstorms. It can cause erratic operation or loss of control.

Do not use the product when visibility is limited.

Do not use the product in rain or snow. Any exposure to moisture (water or snow) may cause erratic operation or loss of control.

Interference may cause loss of control. To ensure the safety of you and others, do not operate in the following places:



Near any site where other radio control activity may occur



Near people or roads



On any pond/lake when passenger boats are present

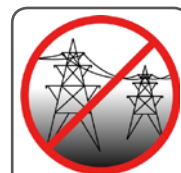

Near power lines or communication broadcasting antennas

Do not use this product when you are tired, uncomfortable, or under the influence of alcohol or drugs. Doing so may cause serious injury to yourself or others.

The 2.4GHz radio band is limited to line of sight. Always keep your model in sight as a large object can block the RF signal and lead to loss of control.

Never grip the transmitter antenna during operation. It significantly degrades signal quality and strength and may cause loss of control.

Do not touch any part of the model that may generate heat during operation, or immediately after use. The engine, motor or speed control, may be very hot and can cause serious burns.

Misuse of this product may lead to serious injury or death. To ensure the safety of you and your equipment, read this manual and follow the instructions.

Make sure the product is properly installed in your model. Failure to do so may result in serious injury.

Make sure to disconnect the receiver battery before turning off the transmitter. Failure to do so may lead to unintended operation and cause an accident.

Ensure that all motors operate in the correct direction. If not, adjust the direction first.

Make sure the model stays within the transmitters range. Otherwise, it would cause loss of control.

Only use specified battery.

Do not open, disassemble, or attempt to repair the battery.

Do not crush/puncture the battery, or short the external contacts.

Do not expose to excessive heat or liquids.

Do not drop the battery or expose to strong shocks or vibrations.

Always store the battery in a cool, dry place.

Transmitter Overview

► Front view:

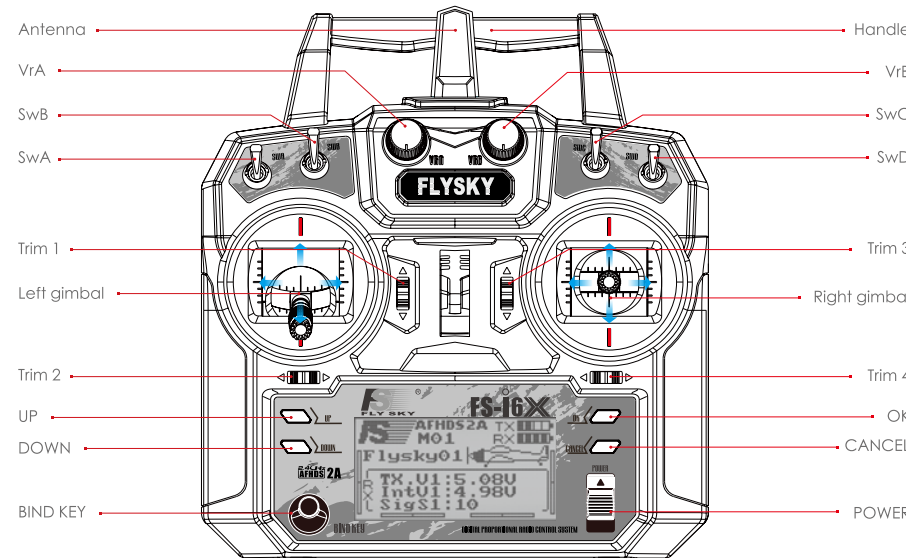

► Rear view:

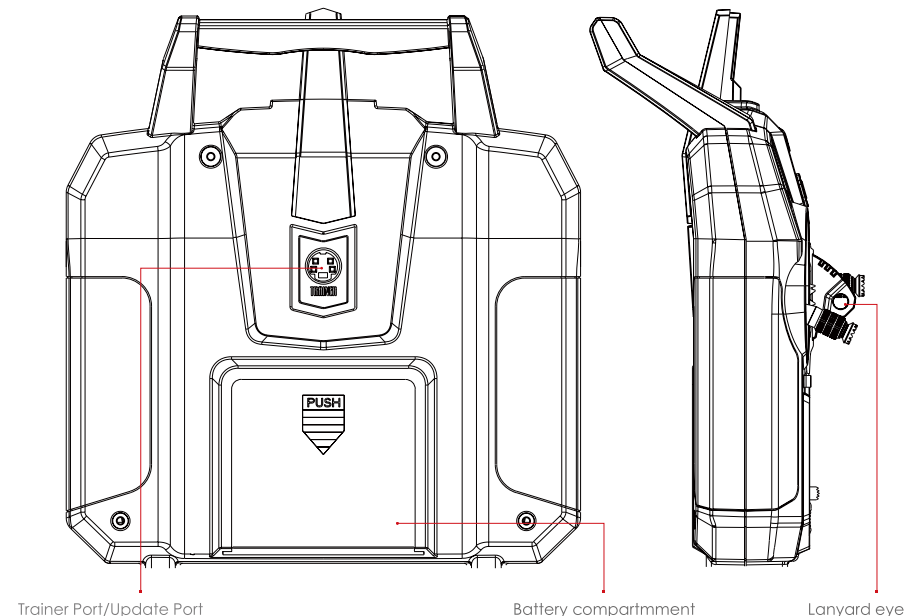

Basic Operations

► Install the Battery

1. Remove the battery compartment cover.
2. Insert 4 fully-charged AA batteries into the compartment. Make sure that the batteries make good contact with the battery compartments' contacts, with the correct polarity.
3. Replace the battery compartment cover.

► Power On

1. Make sure that the receiver is powered off and correctly installed with a fully charged battery.
2. Make sure that all switches are at their highest position and the throttle is at its lowest position.
3. Toggle the power switch to its upward position.
4. Connect the receivers' power supply.

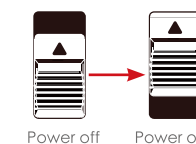

! If the switches and throttle are not in their correct positions, the system will display a warning message.

! If a switch has been activated in the AUX switches function but has not been installed on the system, the transmitter may not turn on. In this case to turn on the transmitter, toggle the power switch to its on position, press the ok key to bring up AUX switches and deactivate the switch.

► Bind with Receiver

The transmitter and receiver have been pre-bound before delivery. If you are using another transmitter or receiver, follow the steps below to bind the transmitter and receiver:

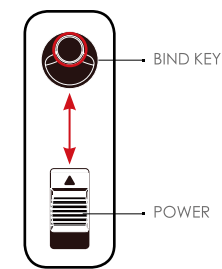

1. Connect the supplied bind cable to the B/VCC port on the receiver.
2. Insert power into any other port.
3. Hold the "BIND KEY" while powering on the transmitter to enter bind mode. The transmitter will then display "RX binding".
4. Remove the power and bind cable from the receiver, then connect the power cable to the B/VCC port.
5. Test the servos range of movement. If anything does not work as expected, restart this procedure from the beginning.

► Power off

1. Disconnect the receiver power.
 2. Toggle the transmitter's power switch to its low position.
- ! Make sure to disconnect the receiver's power before turning off the transmitter. If the receiver is still on, the system will prompt "For your safety, please turn off the receiver first.". If you turn off the transmitter forcefully, it may lead to unintended operation and cause an accident.

Specifications

Channels	6-10 (Default 6)
Model Type	Fixed-Wing/Glider/Helicopter
RF Range	2.408-2.475GHz
RF power	< 20dBm
RF Channel	135
Bandwidth	500KHz
2.4GHz System	AFHDS 2A / AFDHS
Modulation Type	GFSK
Stick Resolution	4096
Low Voltage Warning	< 4.2V
DSC port	PS/2 Port
Chargeable	No
Antenna Length	26mm(Dual Antenna)
Weight	392 g
Power	6V DC 1.5AA*4
Display	STNTransflective Display ,LCD128x64 Lattice, VA 73x 39mm , LCD with white backlight
Size	174x89x190mm
On-line Update	Yes
Color	Black
Certificate	CE, FCC ID:N4ZFLYSKYI6X



Digital Proportional Radio Control System

CE FCC ID:N4ZFLYSKYI6X

[Http://www.flysky-cn.com](http://www.flysky-cn.com)

Copyright © 2017 Flysky Technology co., Ltd

Release date: 2017-07-13