

Front Suspension:

Ride Height: _____
 Camber: _____
 Toe: _____
 Anti-Roll Bar: _____
 Arm Type: _____
 Tower Type: _____
 Wheelbase Shim: _____
 Wheel Hex: _____
 Caster Block: 8° 9° 10°
 Chassis Brace Support: _____
 Top Plate Brace: _____
 Front Axles: CVA DCV
 Notes: _____

Front Chassis Brace Screws:



Steering Rack:



Axle Height: +3 +2 +1 0
 Ball Stud Spacing: _____
 Steering Plate: _____

Arm Mount A:



Ball Stud Spacing:

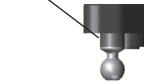

Ball Stud Spacing:

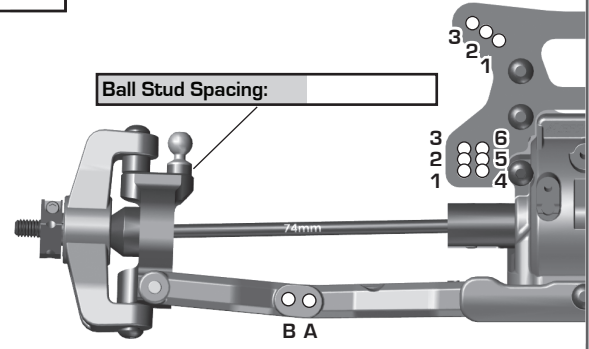

Arm Mount B:



Diff Height:

+2
 +0

Rear Suspension:

Ride Height: _____
 Camber: _____
 Anti-Roll Bar: _____
 Arm Type: _____
 Wheelbase Shim: _____
 Wheel Hex: _____
 Chassis Brace Support: _____
 Hub Spacing: Fwd Mid Back
 Notes: _____

Rear Chassis Brace Screws:

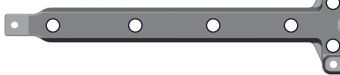

Diff Height:

+3
 +2
 +1
 +0

Vertical Ball Stud Mount:



Ball Stud Spacing:

Arm Mount C:



Camber Link Spacing:

Ball Stud Spacing:

Axle Height:

▼0 3 ▲ +3
 ▼1 2 ▲ +2
 ▲1 2 ▼ +1
 ▲0 3 ▼ +0

Arm Mount D:

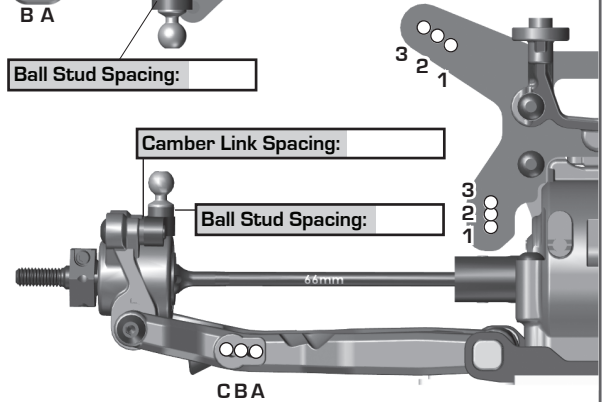

Electronics:

Radio: _____ Servo: _____
 EPA: Throttle: _____ % Brake: _____ %
 ESC: _____
 ESC Settings: _____
 Motor / Wind: _____ Timing: _____
 Pinion: _____ Spur: _____
 Battery: _____
 Battery Position: Back 1 2 3 4 Forward
 Battery Weight: _____

Differential:

	Front	Center	Rear
Fluid:	_____	_____	_____
Gears:	_____	_____	_____
Type:	_____	_____	_____
Notes:	_____		

Shocks:

	Front	Rear
Piston:	_____	_____
Thickness:	_____	_____
Fluid:	_____	_____
Spring:	_____	_____
Limiters:	Int: _____ Ext: _____	Int: _____ Ext: _____
Stroke:	_____	_____
Eyelet Length:	_____	_____
Cup Offset:	_____	_____
Notes:	_____	



Slipper Clutch:

Type: _____
 # of Pads: _____
 Setting: _____

Track Info:

Size: Small Medium Large Extra Large
 Surface: Dirt Carpet Astroturf Multi Surface
 Traction: Low Medium High Very High
 Moisture: Dry Damp Wet
 Condition: Indoor Outdoor Bumpy Smooth
 Temperature: Ambient: _____ Track: _____
 Vehicle Comments: _____

Tires:

Front Tires / Compound / Insert / Wheel: _____

 Rear Tires / Compound / Insert / Wheel: _____

 Notes: _____

Body, Wing, Weight:

Body: _____
 Front Wing: Yes No
 Rear Wing: _____
 Wing Angle: 0° 6°
 Wing Mount Height: 0 -2
 Total Vehicle Weight: _____