

**Front Suspension:**

Ride Height: \_\_\_\_\_  
 Camber: \_\_\_\_\_  
 Toe: \_\_\_\_\_  
 Anti-Roll Bar: \_\_\_\_\_  
 Arm Type: \_\_\_\_\_  
 Tower Type: \_\_\_\_\_  
 Wheel Hex: \_\_\_\_\_  
 Steering Block KPI: \_\_\_\_\_  
 Caster Block Insert: 0  +2.5  +5   
 Bulkhead Type: \_\_\_\_\_  
 Kick-Up Angle: -2.5  0  +2.5   
 Steering Stop Spacing: \_\_\_\_\_  
 Caster Block Spacing: Fwd  Back   
 Notes: \_\_\_\_\_

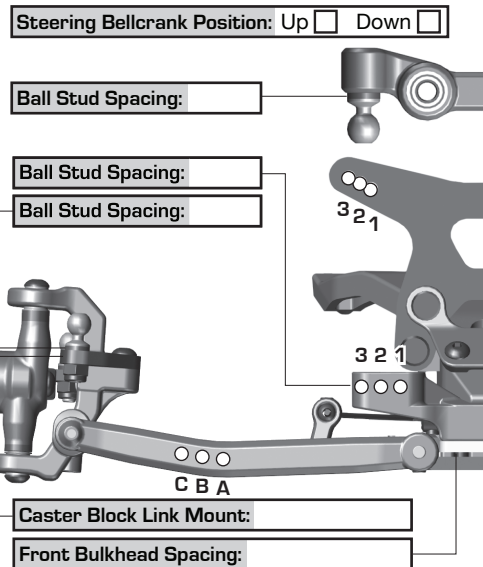
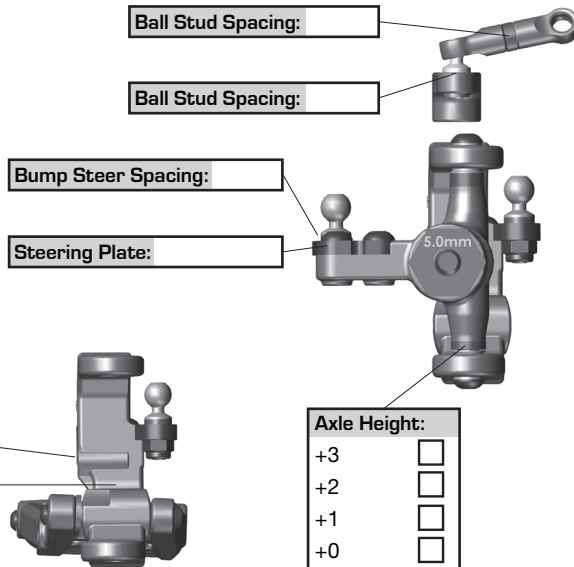

**Rear Suspension:**

Ride Height: \_\_\_\_\_  
 Camber: \_\_\_\_\_  
 Anti-Roll Bar: \_\_\_\_\_  
 Arm Type: \_\_\_\_\_  
 Tower Type: \_\_\_\_\_  
 Arm Spacing: Fwd  Mid  Back   
 Wheel Hex: \_\_\_\_\_  
 Hub Type: Std  HRC   
 Hub Spacing: Fwd  Mid  Back   
 Drive Shaft: CVA's  Universals   
 Notes: \_\_\_\_\_

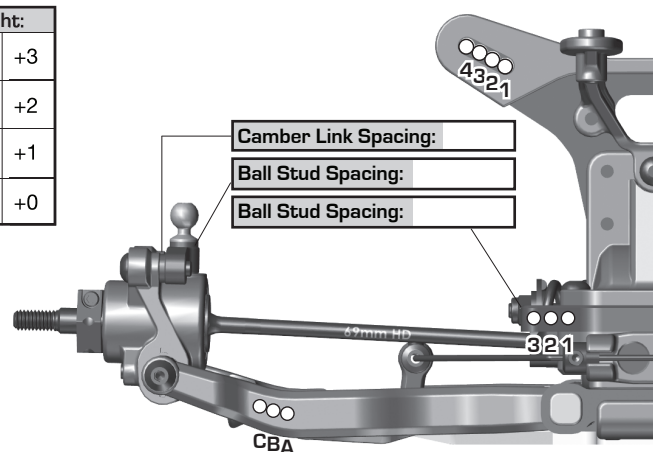
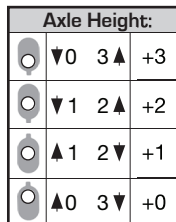
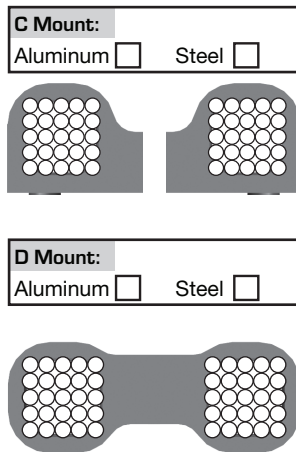

**Electronics:**

Radio: \_\_\_\_\_ Servo: \_\_\_\_\_  
 EPA: Throttle: \_\_\_\_\_ % Brake: \_\_\_\_\_ %  
 ESC: \_\_\_\_\_  
 ESC Settings: \_\_\_\_\_  
 Motor / Wind: \_\_\_\_\_ Timing: \_\_\_\_\_  
 Pinion: \_\_\_\_\_ Spur: \_\_\_\_\_  
 Battery Mount: Std  Offset   
 Back 1  2  3  4  5  Forward  
 Battery: \_\_\_\_\_ Weight: \_\_\_\_\_  
 Notes: \_\_\_\_\_

**Drivetrain:**

Differential: Ball Diff:   
 Height: \_\_\_\_\_ Gear Diff:   
 Diff Setting: \_\_\_\_\_  
 Notes: \_\_\_\_\_

**Slipper Clutch:**

Type: \_\_\_\_\_  
 # of Pads: \_\_\_\_\_  
 Setting: \_\_\_\_\_  
 Notes: \_\_\_\_\_

**Shocks:**

	Front	Rear
Piston:	_____	_____
Thickness:	_____	_____
Fluid:	_____	_____
Spring:	_____	_____
Limiters: Int: _____ Ext: _____ Int: _____ Ext: _____		
Stroke:	_____	_____
Eyelet:	_____	_____
Cup Offset: 0 <input type="checkbox"/> +5 <input type="checkbox"/> +9 <input type="checkbox"/> 0 <input type="checkbox"/> +5 <input type="checkbox"/> +9 <input type="checkbox"/>		
Kashima Bodies: <input type="checkbox"/> Chrome Shafts: <input type="checkbox"/> Machined Spacers: <input type="checkbox"/>		
Notes:		

**Track Info:**

Size: \_\_\_\_\_  
 Surface: \_\_\_\_\_  
 Traction: \_\_\_\_\_  
 Moisture: \_\_\_\_\_  
 Condition: \_\_\_\_\_  
 Temperature: \_\_\_\_\_  
 Notes: \_\_\_\_\_

**Tires:**

Front Tires: \_\_\_\_\_  
 Front Compound: \_\_\_\_\_  
 Front Insert: \_\_\_\_\_  
 Rear Tires: \_\_\_\_\_  
 Rear Compound: \_\_\_\_\_  
 Rear Insert: \_\_\_\_\_  
 Wheel (F/R): \_\_\_\_\_  
 Notes: \_\_\_\_\_

**Body, Weight:**

Body: \_\_\_\_\_  
 Front Wing: \_\_\_\_\_  
 Rear Wing: \_\_\_\_\_  
 Wing Angle: 0°  3°  6°   
 Chassis Length: \_\_\_\_\_  
 Servo Weights: \_\_\_\_\_  
 Electronic Weights: \_\_\_\_\_  
 Total Vehicle Weight: \_\_\_\_\_

**Vehicle Comments:**

Notes: \_\_\_\_\_  
 \_\_\_\_\_  
 \_\_\_\_\_  
 \_\_\_\_\_  
 \_\_\_\_\_