

## Front Suspension:

Ride Height: \_\_\_\_\_  
 Camber: \_\_\_\_\_  
 Toe: \_\_\_\_\_  
 Anti-Roll Bar: \_\_\_\_\_  
 Arm Type: \_\_\_\_\_  
 Tower Type: \_\_\_\_\_  
 Wheelbase Shim: \_\_\_\_\_  
 Wheel Hex: \_\_\_\_\_  
 Caster Block: 8°  9°  10°   
 Chassis Brace Support: \_\_\_\_\_  
 Top Plate Brace: \_\_\_\_\_  
 Front Axles: CVA  DCV   
 Notes: \_\_\_\_\_  
 \_\_\_\_\_  
 \_\_\_\_\_

### Front Chassis Brace Screws:



### Steering Rack:



Axle Height: +3  +2  +1  0

Ball Stud Spacing: \_\_\_\_\_

Steering Plate: \_\_\_\_\_

### Arm Mount A:



### Ball Stud Spacing:

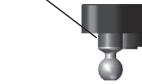

Ball Stud Spacing: \_\_\_\_\_

### Arm Mount B:



### Diff Height:

+2   
 +0

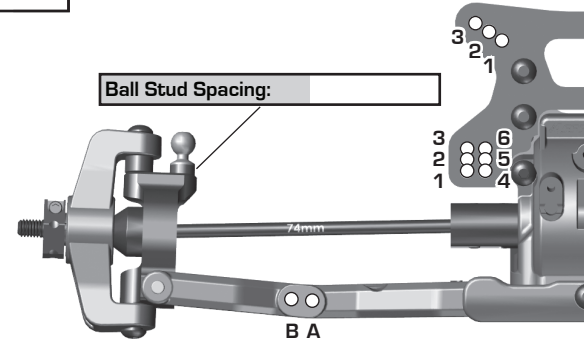

## Rear Suspension:

Ride Height: \_\_\_\_\_  
 Camber: \_\_\_\_\_  
 Anti-Roll Bar: \_\_\_\_\_  
 Arm Type: \_\_\_\_\_  
 Wheelbase Shim: \_\_\_\_\_  
 Wheel Hex: \_\_\_\_\_  
 Chassis Brace Support: \_\_\_\_\_  
 Hub Spacing: Fwd  Mid  Back   
 Notes: \_\_\_\_\_  
 \_\_\_\_\_  
 \_\_\_\_\_

### Rear Chassis Brace Screws:

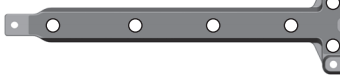

### Diff Height:

+3   
 +2   
 +1   
 +0

### Vertical Ball Stud Mount:



Ball Stud Spacing: \_\_\_\_\_

### Arm Mount C:



Camber Link Spacing: \_\_\_\_\_

### Arm Mount D:



### Axle Height:

▼0 3 ▲ +3  
 ▼1 2 ▲ +2  
 ▲1 2 ▼ +1  
 ▲0 3 ▼ +0

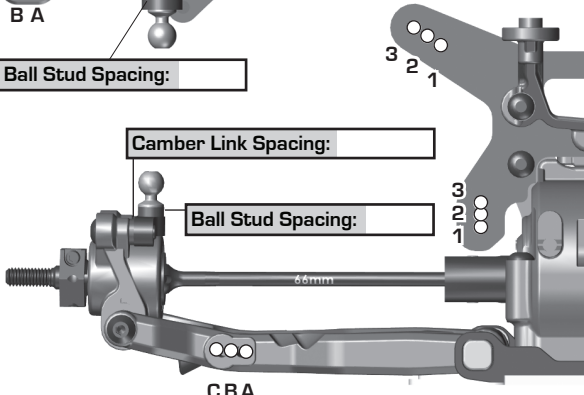

## Electronics:

Radio: \_\_\_\_\_ Servo: \_\_\_\_\_  
 EPA: Throttle: \_\_\_\_\_ % Brake: \_\_\_\_\_ %  
 ESC: \_\_\_\_\_  
 ESC Settings: \_\_\_\_\_  
 Motor / Wind: \_\_\_\_\_ Timing: \_\_\_\_\_  
 Pinion: \_\_\_\_\_ Spur: \_\_\_\_\_  
 Battery: \_\_\_\_\_  
 Battery Position: Back 1  2  3  4  Forward  
 Battery Weight: \_\_\_\_\_

## Differential:

	Front	Center	Rear
Fluid:	_____	_____	_____
Gears:	_____	_____	_____
Type:	_____	_____	_____
Notes:	_____		

## Shocks:

	Front	Rear
Piston:	_____	_____
Thickness:	_____	_____
Fluid:	_____	_____
Spring:	_____	_____
Limiters:	Int: _____ Ext: _____	Int: _____ Ext: _____
Stroke:	_____	_____
Eyelet Length:	_____	_____
Cup Offset:	_____	_____
Notes:	_____	



## Slipper Clutch:

Type: \_\_\_\_\_  
 # of Pads: \_\_\_\_\_  
 Setting: \_\_\_\_\_

## Track Info:

Size: Small  Medium  Large  Extra Large   
 Surface: Dirt  Carpet  Astroturf  Multi Surface   
 Traction: Low  Medium  High  Very High   
 Moisture: Dry  Damp  Wet   
 Condition: Indoor  Outdoor  Bumpy  Smooth   
 Temperature: Ambient: \_\_\_\_\_ Track: \_\_\_\_\_  
 Vehicle Comments: \_\_\_\_\_

## Tires:

Front Tires / Compound / Insert / Wheel: \_\_\_\_\_  
 \_\_\_\_\_  
 Rear Tires / Compound / Insert / Wheel: \_\_\_\_\_  
 \_\_\_\_\_  
 Notes: \_\_\_\_\_

## Body, Wing, Weight:

Body: \_\_\_\_\_  
 Front Wing: Yes  No   
 Rear Wing: \_\_\_\_\_  
 Wing Angle: 0°  6°   
 Wing Mount Height: 0  -2   
 Total Vehicle Weight: \_\_\_\_\_