

Front Suspension:

Ride Height: _____
 Toe: _____ Hex: _____
 Anti-Roll Bar
 Size: _____
 Gap: _____
 Ackerman
 1 2 3 4 01
 Steering Arm Plate:
 Drive Shaft: CVAs: Universals:
 Notes: _____

Caster Shim: _____
 Insert Type: _____
 Upper Ball Type: _____
 Upper Ball Shim: _____
 Washers: _____
 Lower Ball Shim: _____

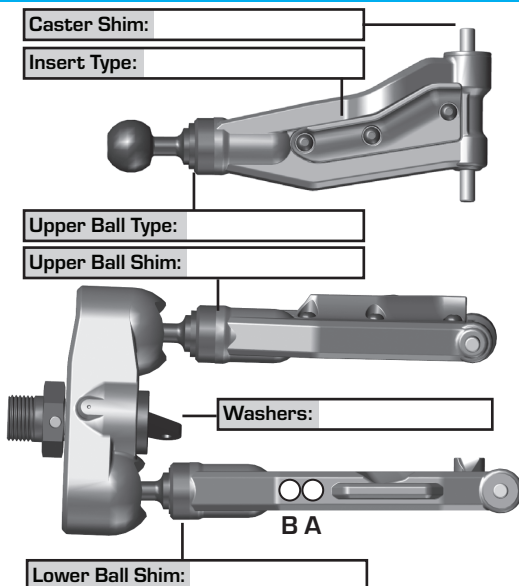

Wheelbase Shim: _____
 Lower Ball Type: _____
 Insert Type: _____
 Insert Location: Top: Bottom:
 Upper Arm Mount: _____
 Arm Mount A: _____
 Arm Mount B: _____

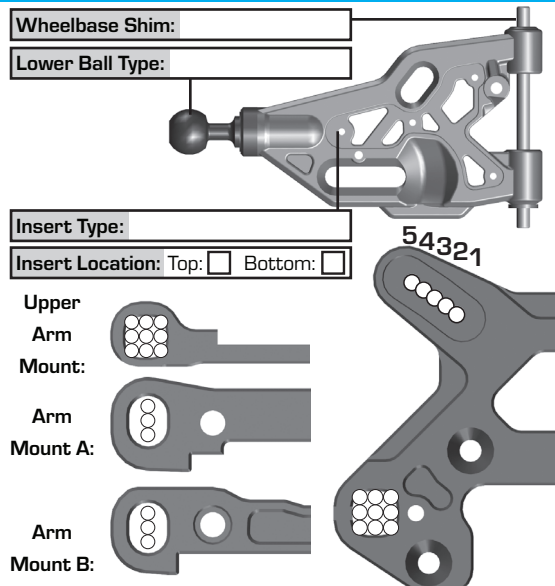

Rear Suspension:

Ride Height: _____
 Camber: _____ Hex: _____
 Anti-Roll Bar
 Size: _____
 Gap: _____
 Drive Shaft: CVAs: Universals:
 Chassis Brace:
 Ball:
 Inserts:
 Notes: _____

Hub Shim: _____
 Wheelbase Shim: _____
 CBA
 B A
 Insert Type: _____
 Insert Location: Top: Bottom:

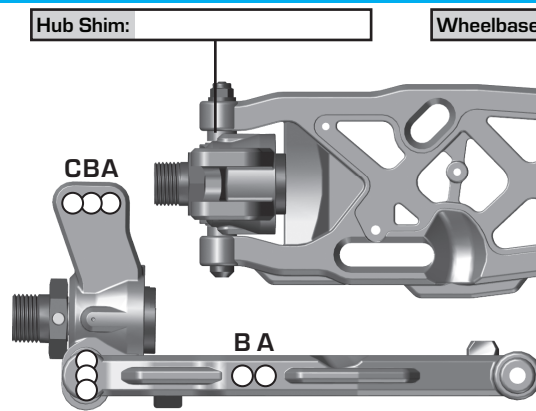

Arm Mount C: _____
 Arm Mount D: _____
 Wing Height:
 High:
 Low:
 6 5 4 3 2 1

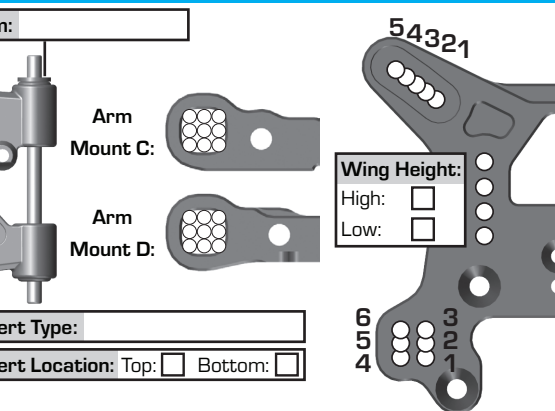

Electronics:

Radio: _____ Servo: _____
 EPA: Throttle: _____ % Brake: _____ %
 EXPO: Throttle: _____ % Brake: _____ %
 ESC: _____ Motor: _____
 Battery: Saddle Brick
 Battery Position: Rear Center Forward
 Battery Tray Position: Rear Forward
 Notes: _____

Differential:

	Front	Center	Rear
Fluid:			
Gears:			
Mass:			
Notes:	_____		

Gearing:
 Spur Gear: _____ Pinion: _____
 Notes: _____

Shocks:

	Front	Rear
Piston:		
Fluid:		
Bladder:		
Rebound:		
Spring:		
Length:		
Notes:	_____	

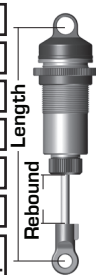

Track Info:

Size: Small Medium Large Extra Large
 Surface: Dirt Carpet AstroTurf Multi Surface
 Traction: Low Medium High Very High
 Moisture: Dry Damp Wet
 Condition: Indoor Outdoor Dusty Hard Packed
 Bumpy Grooved Smooth Loamy
 Temperature: Ambient: _____ Track: _____
 Notes: _____

Tires:

Front Tire/Compound/Insert/Wheel: _____
 Rear Tire/Compound/Insert/Wheel: _____
 Notes: _____
Radio Tray Flex Assembly:
 Transponder Mount: None:
 Radio Tray Brace:

Body and Wing:

Body: _____
 Nose Cone: _____
 Rear Wing: _____
 Angle: 0° 2° 4° Button: Flat Fin
 Vent Holes: _____
Weight:
 Total Weight: _____
 Notes: _____

Vehicle Comments:

Notes: _____