

Engine	Gasket	mm	Plug	Muffler	Fuel						
Clutch ball	<input checked="" type="checkbox"/> 131	<input type="checkbox"/> 14T	<input type="checkbox"/> Other T	Spur gear	<input type="checkbox"/> T	<input type="checkbox"/> Other T	Shoes	<input checked="" type="checkbox"/> 3	<input type="checkbox"/> 4	Spring	mm
Diff Front:	<input type="checkbox"/> LSD	Oil #	Center:	<input type="checkbox"/> LSD	Oil #	Rear:	<input type="checkbox"/> LSD	Oil #			

Front Suspension

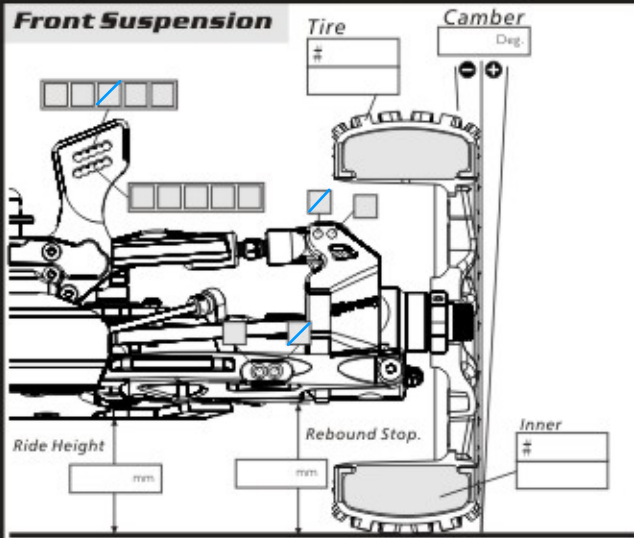

Front

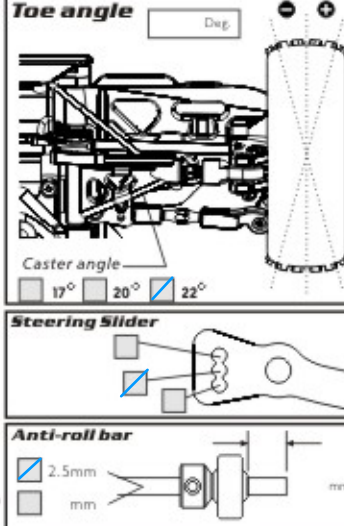

Front Shock

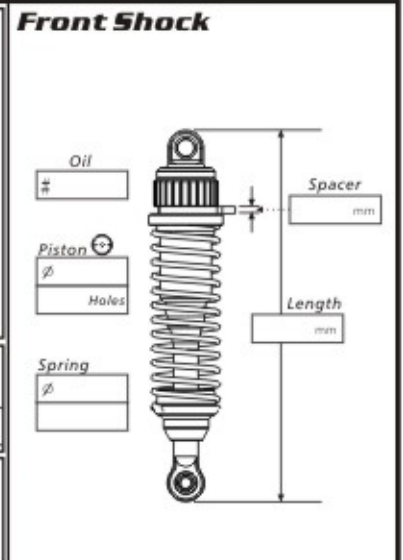

Rear Suspension

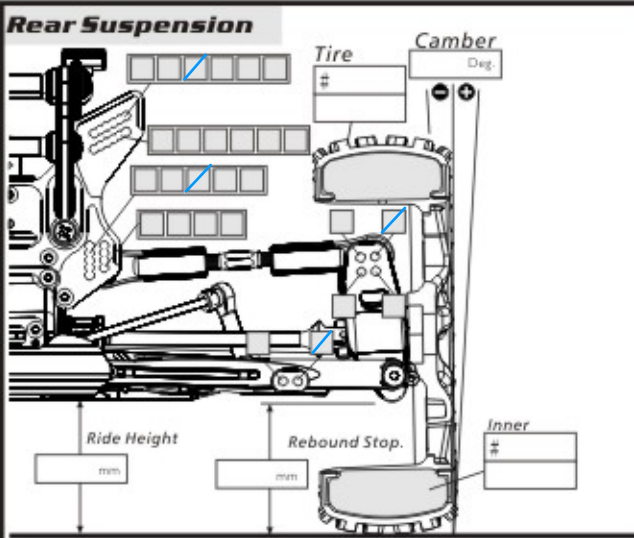

Rear

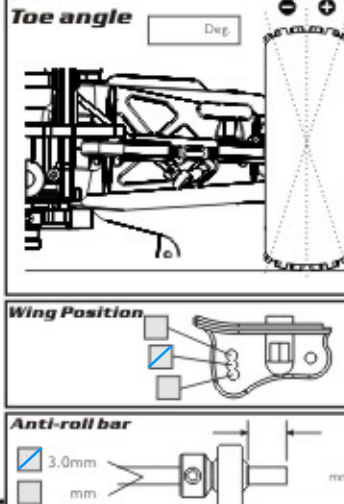

Rear Shock

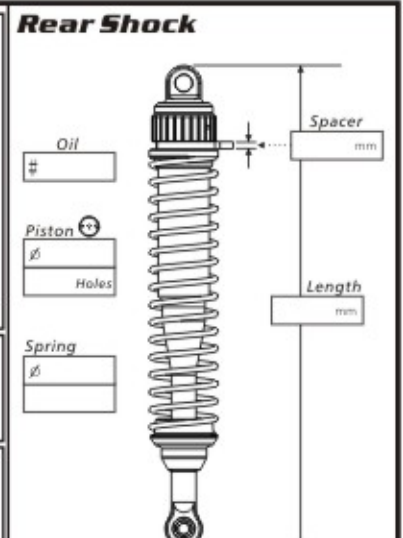

Notes:

Result	Position	Laps	Time	Fastest Lap
Run				Lap
Qualifier				Lap
				Lap
				Lap
				Lap
Main#				Lap

