

## Setup Sheet

### Front Suspension

#### Anti Roll Bar:

- 0.047" Black   
 0.055" Silver   
 None



Bumpsteer Washer: \_\_\_\_\_

Camber: \_\_\_\_\_

Toe: \_\_\_\_\_

Ride Height: \_\_\_\_\_

Steering rack Washer: \_\_\_\_\_

Washers: \_\_\_\_\_



Steering Rack: Kit  Option: \_\_\_\_\_

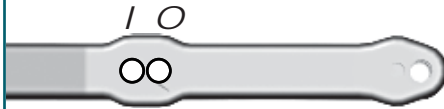

Notes: \_\_\_\_\_

### Rear Suspension

#### Anti Roll Bar:

- 0.047" Black   
 0.055" Silver   
 None

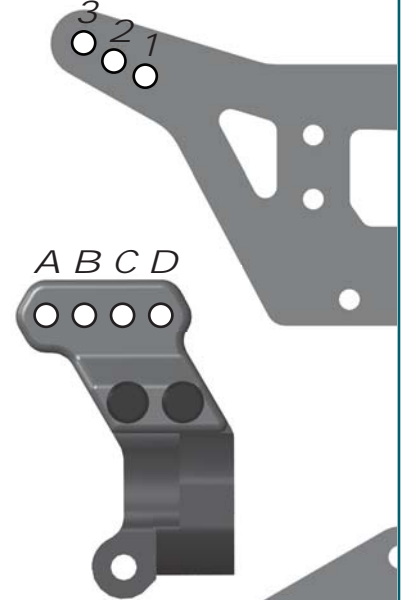

Camber: \_\_\_\_\_

Toe: \_\_\_\_\_

Ride Height: \_\_\_\_\_

Anti-Squat: \_\_\_\_\_

#### Aluminum

#### Hub Tower:

- A   
 B   
 C

#### Wheelbase:

- Long   
 Medium   
 Short

Washers: \_\_\_\_\_

Notes: \_\_\_\_\_

### Front Shocks

Spring: \_\_\_\_\_ Piston: \_\_\_\_\_  
 Shock Oil: \_\_\_\_\_ Limiter: \_\_\_\_\_ Stroke: \_\_\_\_\_

### Rear Shocks

Spring: \_\_\_\_\_ Piston: \_\_\_\_\_  
 Shock Oil: \_\_\_\_\_ Limiter: \_\_\_\_\_ Stroke: \_\_\_\_\_

### Drivetrain

Slipper: Yes  No   
 Type: \_\_\_\_\_  
 Pads: \_\_\_\_\_  
 Notes: \_\_\_\_\_

### Differentials

Front: \_\_\_\_\_  
 Center: \_\_\_\_\_  
 Rear: \_\_\_\_\_  
 Notes: \_\_\_\_\_

### Electronics

Radio: \_\_\_\_\_  
 Throttle / Brake E.P.A.: \_\_\_\_\_  
 Throttle / Brake Expo: \_\_\_\_\_  
 Servo: \_\_\_\_\_ Steering Expo: \_\_\_\_\_  
 ESC: \_\_\_\_\_  
 ESC Settings: \_\_\_\_\_  
 Motor & Wind: \_\_\_\_\_  
 Pinion: \_\_\_\_\_ Spur Gear: \_\_\_\_\_  
 Batteries: \_\_\_\_\_  
 Motor Placement: Front  Back   
 Battery Placement: Front  Back  Shorty

### Tires

Tire (F/R): \_\_\_\_\_ / \_\_\_\_\_  
 Compound (F/R): \_\_\_\_\_ / \_\_\_\_\_  
 Insert (F/R): \_\_\_\_\_ / \_\_\_\_\_  
 Wheel (F/R): \_\_\_\_\_ / \_\_\_\_\_  
 Notes: \_\_\_\_\_

### Body & Wing

Body Type: \_\_\_\_\_  
 Wing Type: \_\_\_\_\_ Wing Angle: \_\_\_\_\_

### Weight

Ballast Weight: \_\_\_\_\_  
 Chassis Weight: \_\_\_\_\_ Total: \_\_\_\_\_

### Race and Vehicle Comments

Qualify: \_\_\_\_\_ Main: \_\_\_\_\_ Finish: \_\_\_\_\_ TQ: \_\_\_\_\_  
 Comments: \_\_\_\_\_

### Track Info

Composition: Astroturf  Blue Groove  Carpet  Clay   
 Grass  Soft Dirt  Other: \_\_\_\_\_  
 Traction: High  Medium  Low  Dusty   
 Surface: Bumpy  Smooth  Dry  Wet   
 Comments: \_\_\_\_\_