

B4.2RS

RACE - SPEC



#9042 B4.2 RS RTR

**BRUSHLESS
POWERED**
Ready-To-Run

1:10 Scale Electric 2WD Off Road Race Buggy Manual & Catalog

TEAM ASSOCIATED



Designed in California, USA

:: Introduction

Thank you for purchasing this Team Associated product. This assembly manual contains instructions and tips for building and maintaining your new RC10 B4.2. Please take a moment to read through this manual to help familiarize yourself with these steps.

We are continually changing and improving our designs; therefore, actual parts may appear slightly different than in the illustrations. New parts will be noted on supplementary sheets located in the appropriate parts bags. Check each bag for these sheets before you start to build.

:: KIT Features

Features in the B4.2 RS RTR:

- Fully assembled 2WD buggy based on the 5-time I.F.M.A.R. World Champion and 6-time R.O.A.R. National Champion platform
- XP SC500-BL Brushless water resistant speed control with LiPo cutoff
- Powerful Reedy 3300kV brushless motor
- XP 2.4 GHz 2-channel radio system with digital metal gear servo
- Water-resistant enclosed receiver box
- Blue anodized aluminum V2 coil-over shock absorbers
- Heavy-duty sealed gear differential with adjustable slipper clutch
- Factory finished Interceptor 2.0 polycarbonate body
- High traction tires pre-mounted on white hex drive wheels
- Molded composite chassis and battery strap that fits NiMH or LiPo battery packs
- Rugged steel turnbuckles for adjustable camber and front toe-in
- Vertical ball ends for roll center adjustments, front & rear

:: Additional

Your new B4.2 RS RTR comes factory assembled including radio gear, motor, and ESC. However, there are some items you will need to complete your kit (refer to catalog for suggestions):

- AA-size batteries for transmitter (x8)
- 6 cell NiMH battery pack or 2 cell LiPo battery pack
- Battery charger (we recommend a peak detection charger)

Tools included:

- Allen wrenches #6950 (.050", 1/16", 3/32", 5/64")
- 1.5mm allen wrench
- Molded tools #6956
- Camber gauge #1719
- Shock building tool #6429

:: Other Helpful Items

- Silicone Shock Fluid (Refer to catalog for complete listings)
- Body Scissors (AE Part # 1737)
- FT Hex Wrenches (AE Part # 1655)
- Soldering Iron
- Reamer / Hole Punch
- Needle Nose Pliers
- Calipers or a Precision Ruler
- Wire Cutters
- Multi Tool (AE Part #7494)
- Green Slime shock lube (AE Part # 1105)
- Hobby Knife

Associated Electrics, Inc.
26021 Commercentre Dr.
Lake Forest, CA 92630



Customer Service
Tel: 949.544.7500
Fax: 949.544.7501

:: Table of Contents

1..... Cover	15 - 18..... Electronics Build
2..... Introduction	18 - 19..... Wheels, Tires and Body Install
3..... Table of Contents	19..... Servo Chart
4 - 5..... Steering Build	20 - 21..... Tuning Tips
5 - 7..... Front Suspension Build	22 - 30..... Catalog
7 - 9..... Transmission Build	31..... Setup Sheet "Kit Setup"
10 - 11..... Rear End Build	32..... 1:1 Hardware "Fold Out"
12..... Rear Hub Build	33..... Setup Sheet "Blank"
13 - 14..... Shocks Build	34..... Back Cover

:: Notes

This symbol indicates a special note or instruction in the manual.



There is a 1:1 hardware foldout page in the back of the manual. To check the size of a part, line up your hardware with the correct drawing until you find the exact size. Each part in the foldout has a number assigned to it for ordering replacement parts.

**Associated Electrics, Inc.
26021 Commercentre Dr.
Lake Forest, CA 92630**



**Customer Service
Tel: 949.544.7500
Fax: 949.544.7501**

<http://www.TeamAssociated.com> • <http://www.RC10.com> • http://twitter.com/Team_Associated • <http://bit.ly/AEonFacebook>

:: Steering Build - Step 1

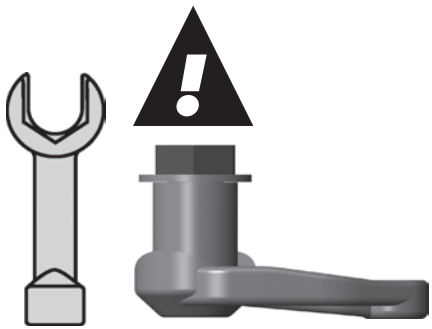

* With supplied wrench, tighten servo saver bolt completely, **until it hits bottom**. Do not overtighten.

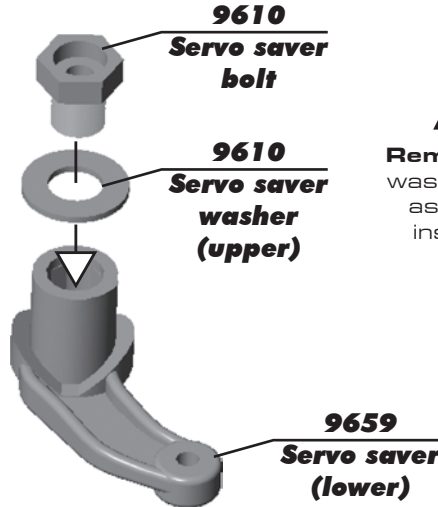

!
Remove bolt and washer, continue assembly per instructions.

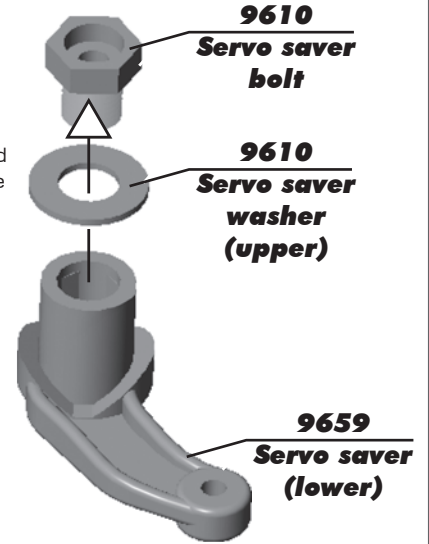

:: Steering Build - Step 2

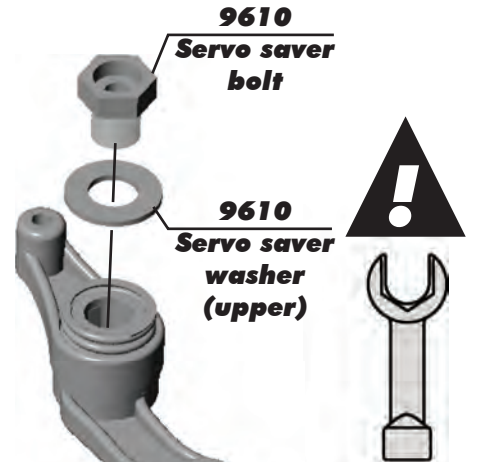
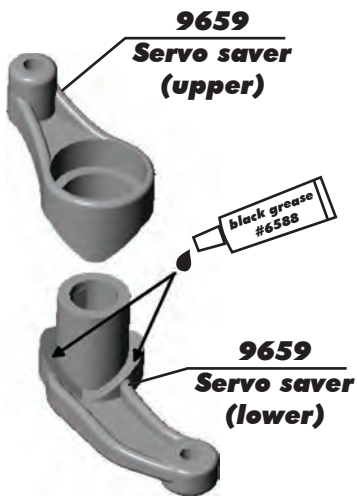

* With supplied wrench, tighten servo saver bolt completely. Do not overtighten.

:: Steering Build - Step 3

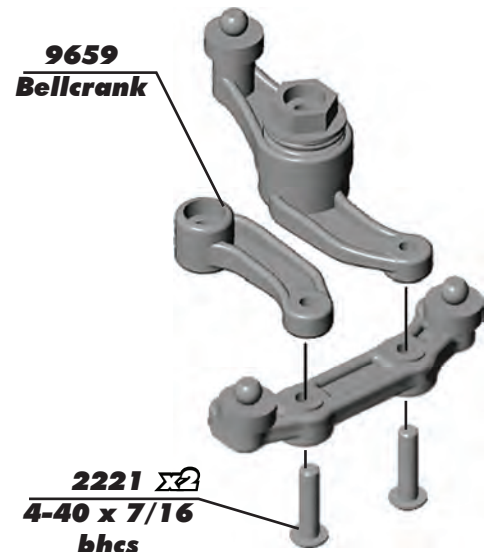
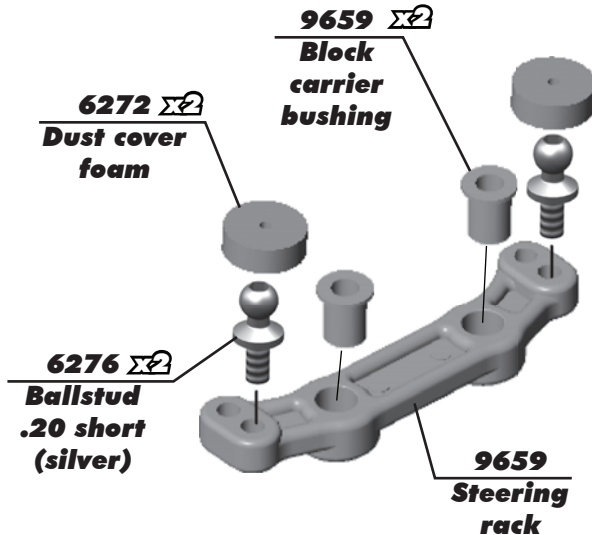

:: Steering Build - Step 4

9566
Top plate

3856
Steering rack bushing

9659
Steering brace

9640
Steering bolt (right)

9640
Steering bolt (left)

9563
Front bulkhead

9560
B4 chassis

6925
4-40 x 1/2 shcs

6915
4-40 x 5/8 fhcs

!

Do not overtighten steering bolts. Make sure there is free movement in the steering rack.

:: Front Suspension Build - Step 1

6272
Foam dust cover

6277
Ballstud .30 long (silver)

4187
.030 washer (nylon)

9880
Steering blocks hex style (left, right)

4449
4-40 x 3/16 aluminum locknut

7496
B4 front axle, hex

3977
3/16x3/8 bearing

9882
C-clip, 3/16

Build 2 (1 left, 1 right)

Build 2!

!

Install the C Clip into the groove shown below.

:: Front Suspension Build - Step 2

3977
3/16 x 3/8 bearing

7497
B4 wheel hex adapter (thin)

7369
1/16" universal roll pin

Build left and right sides!

!

Align the C clip on the front axes with the D shape inside the steering blocks.

:: Front Suspension Build - Step 3

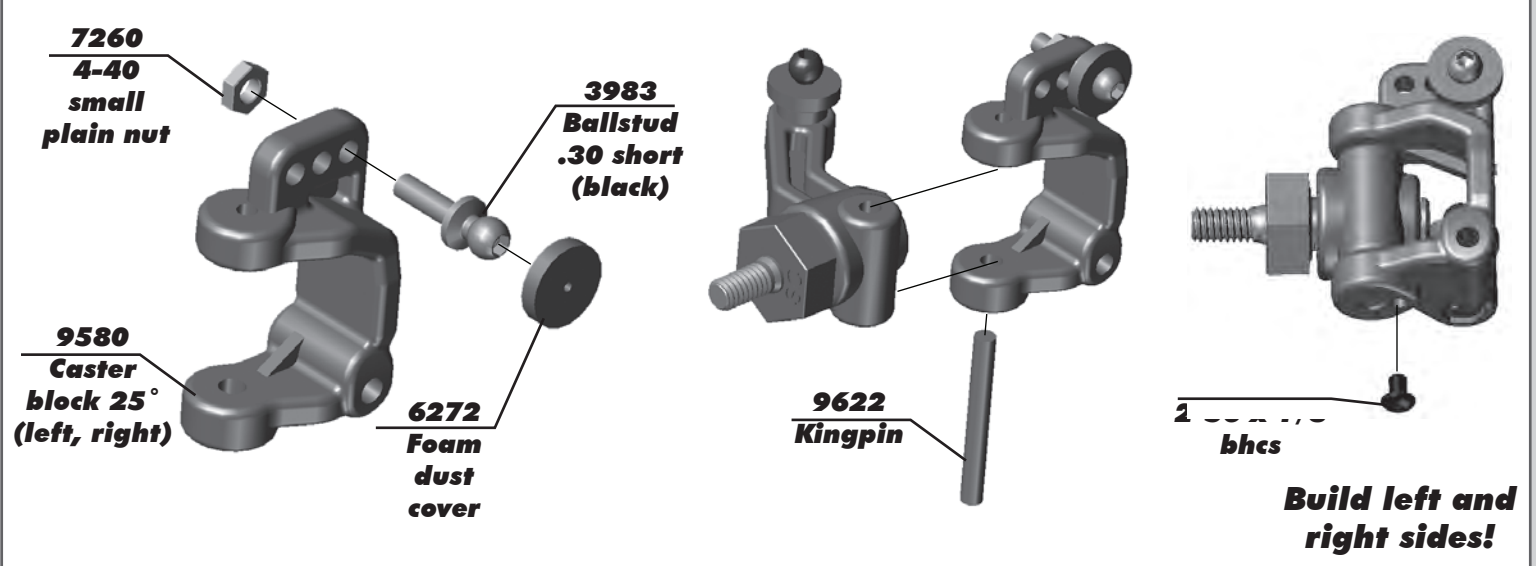

:: Front Suspension Build - Step 4

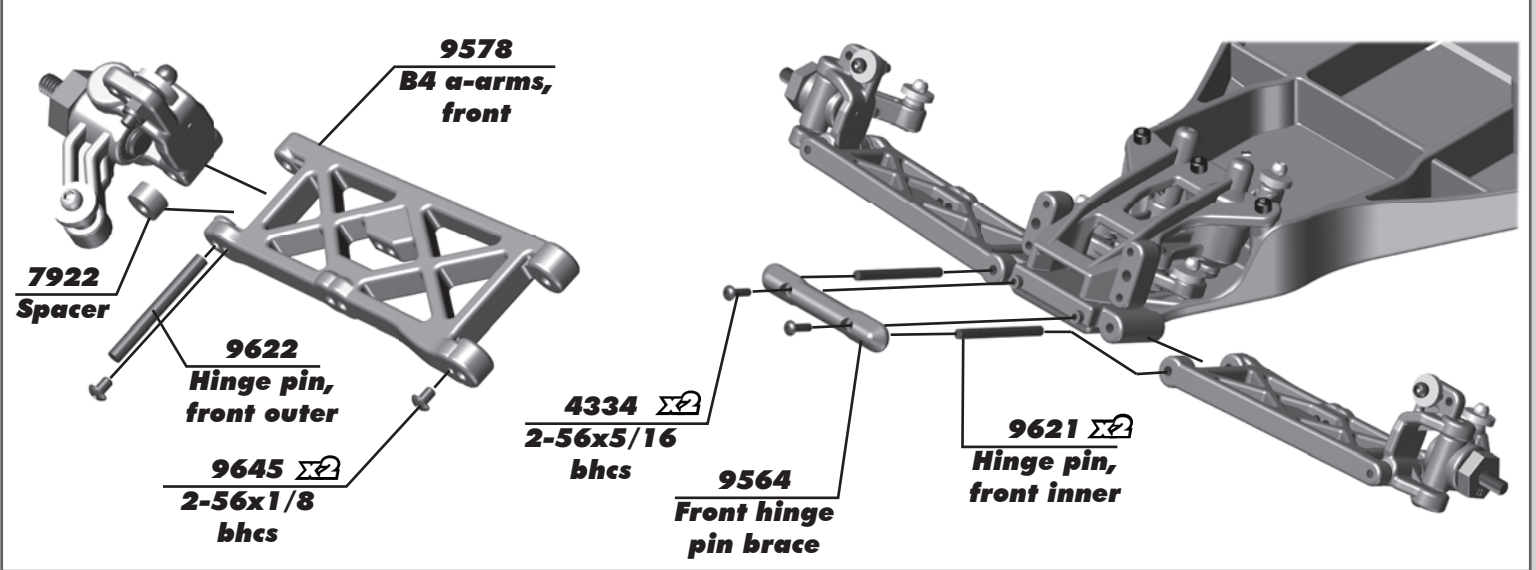

:: Front Suspension Build - Step 5

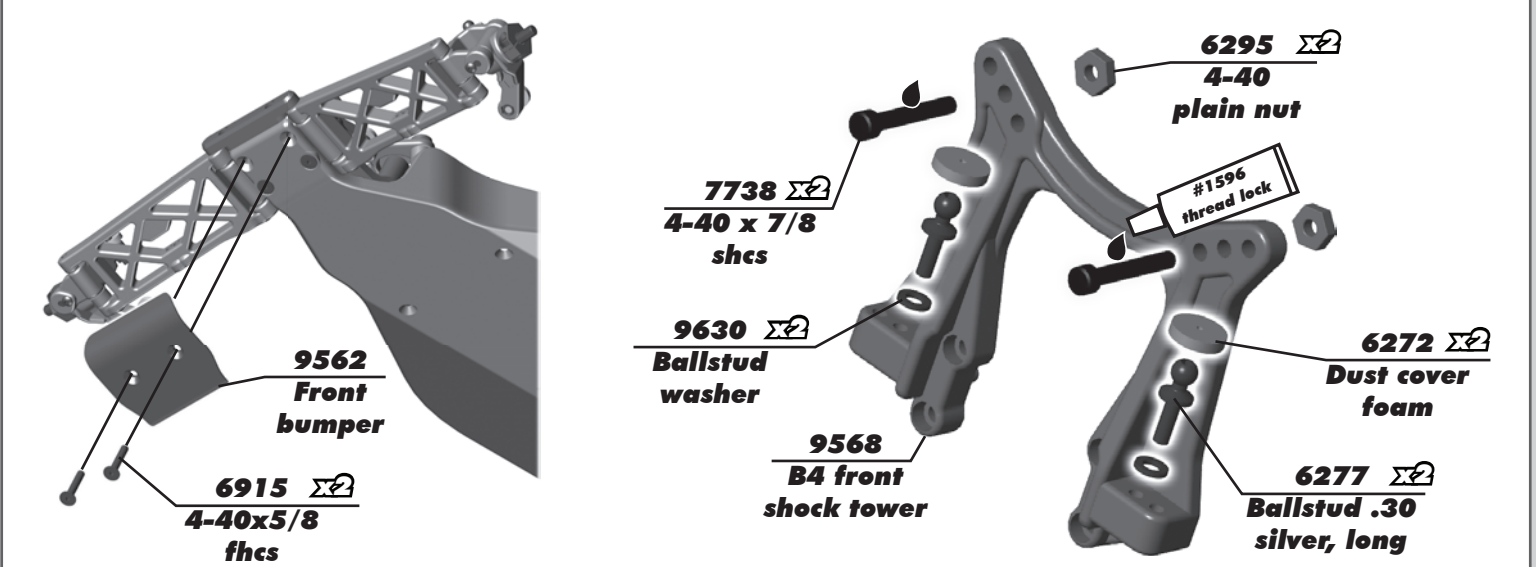

:: Front Suspension Build - Step 6

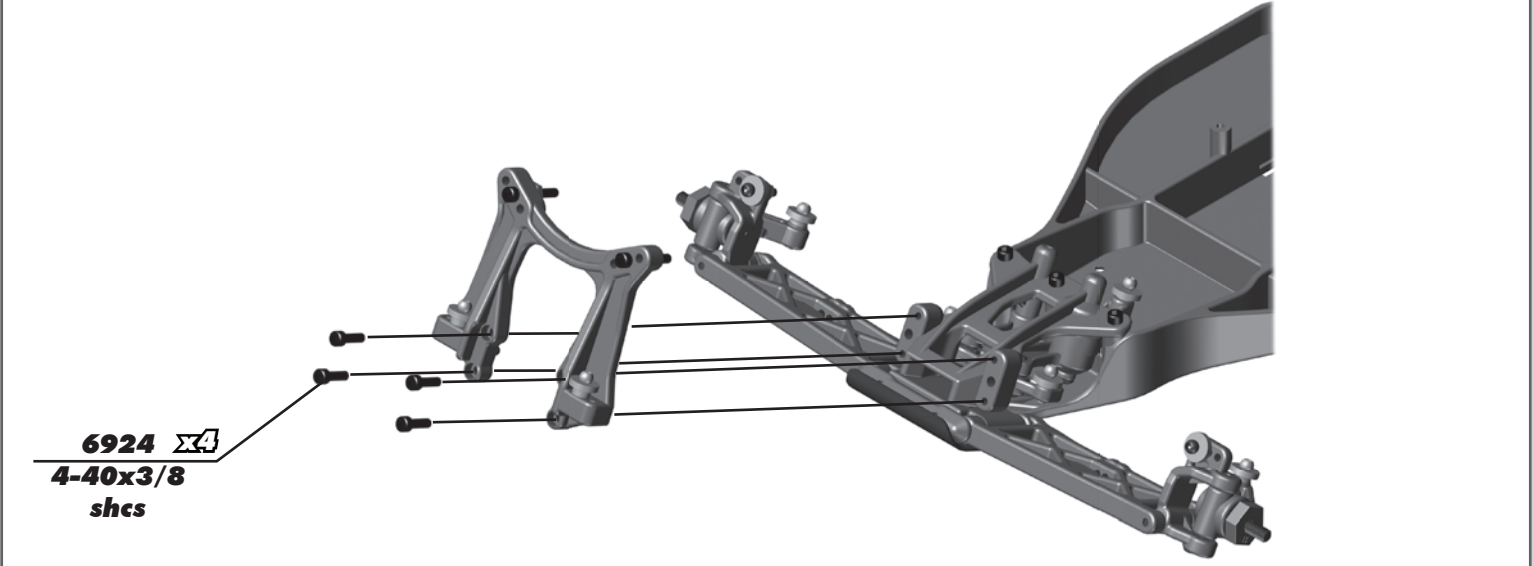

:: Front Suspension Build - Step 7

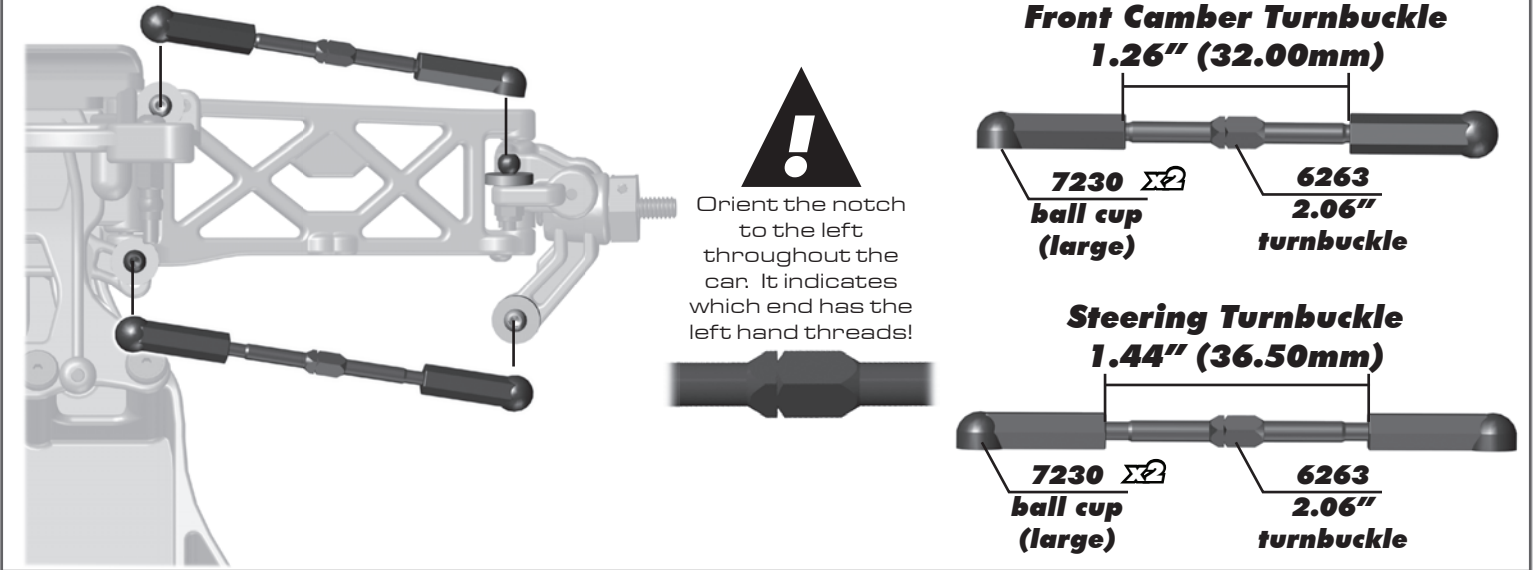

:: Transmission Build - Step 1

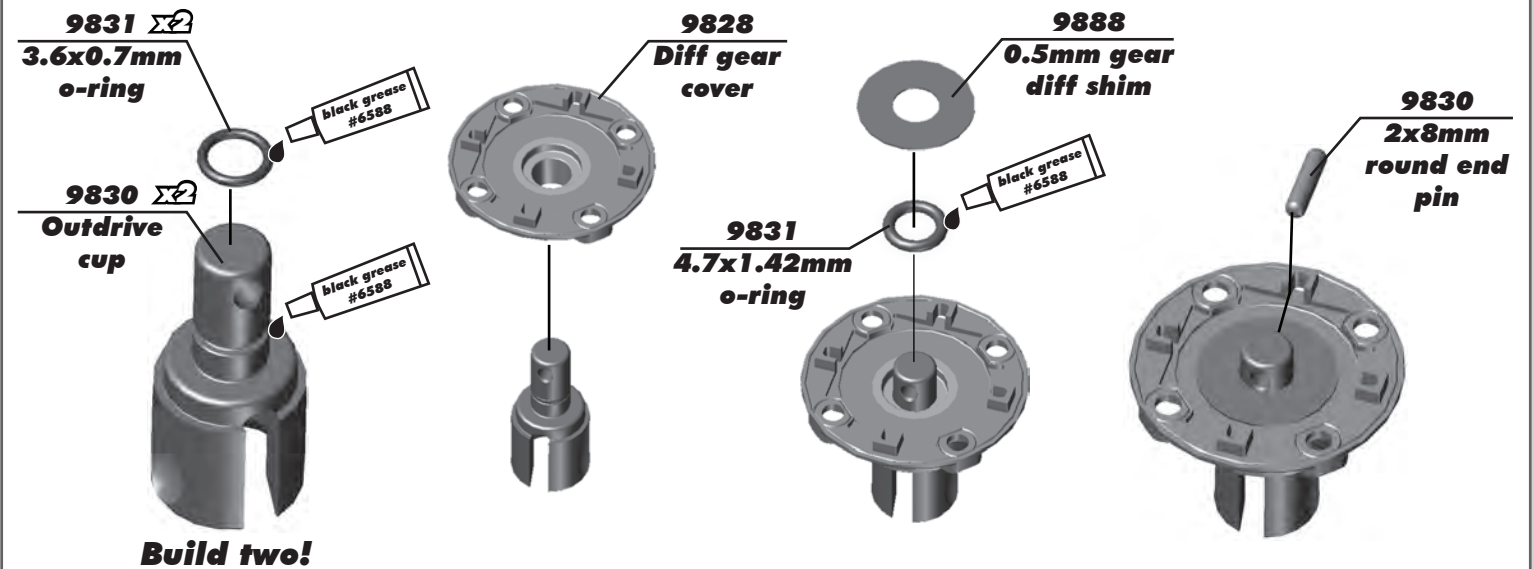

:: Transmission Build - Step 2

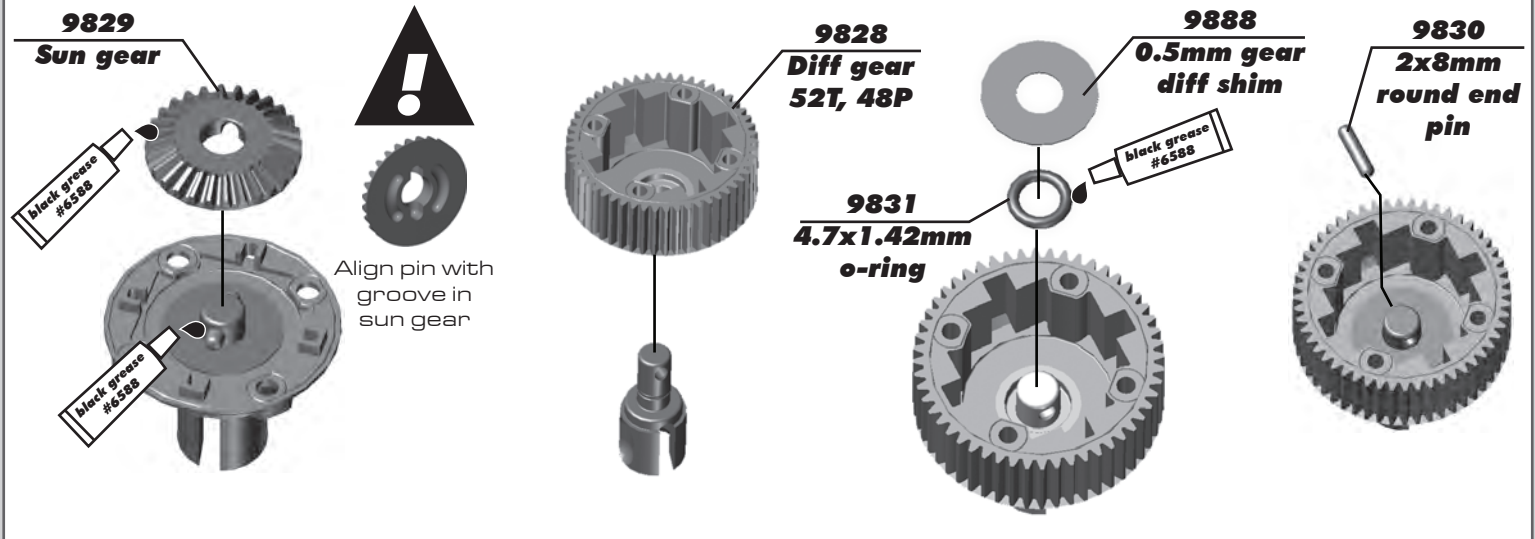

:: Transmission Build - Step 3

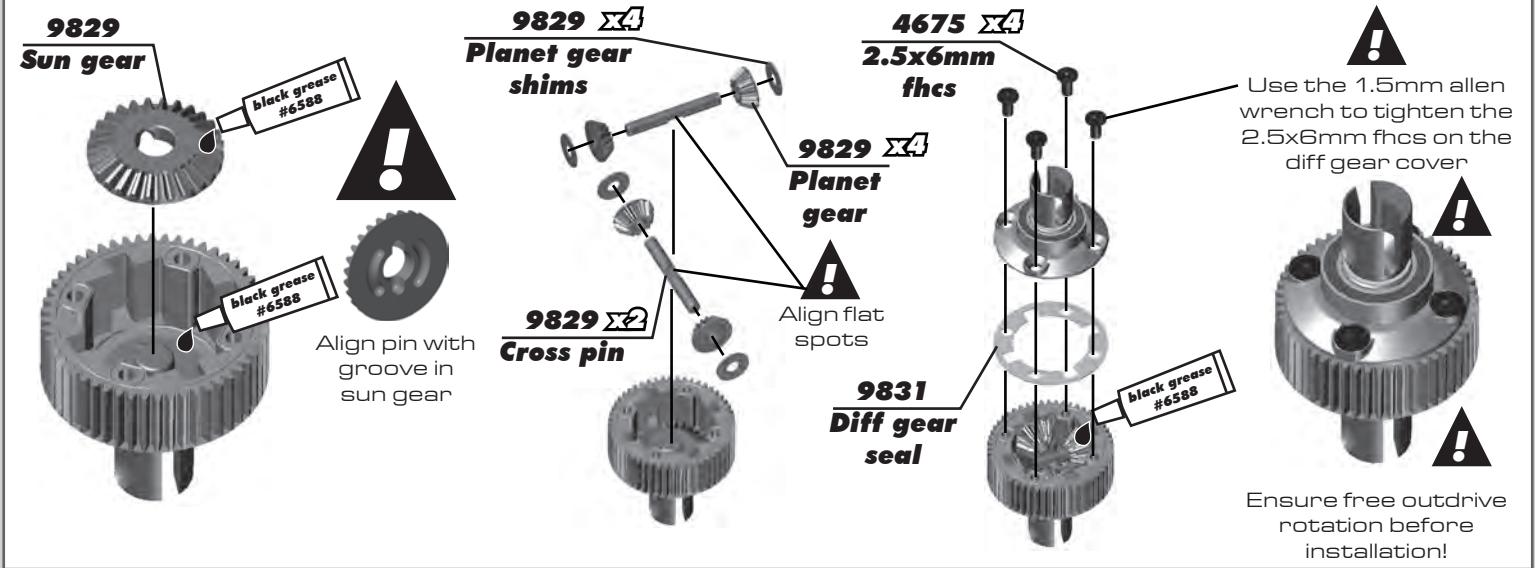

:: Transmission Build - Step 4

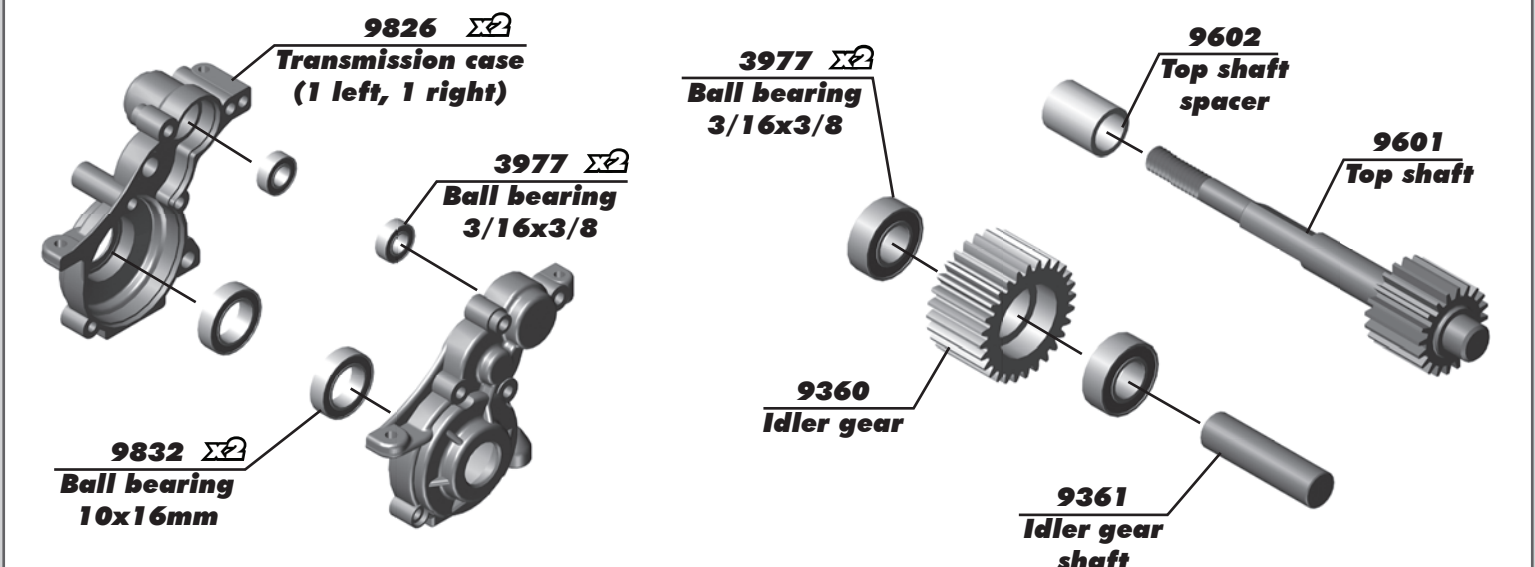

:: Transmission Build - Step 5

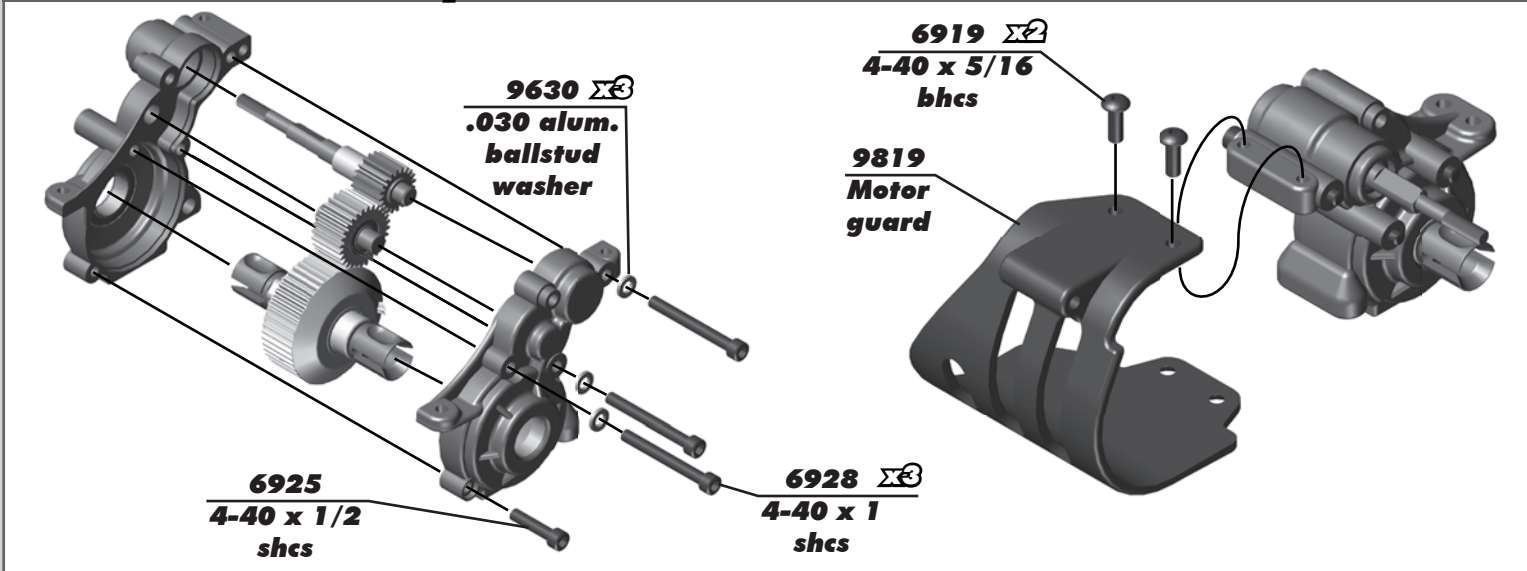

:: Transmission Build - Step 6

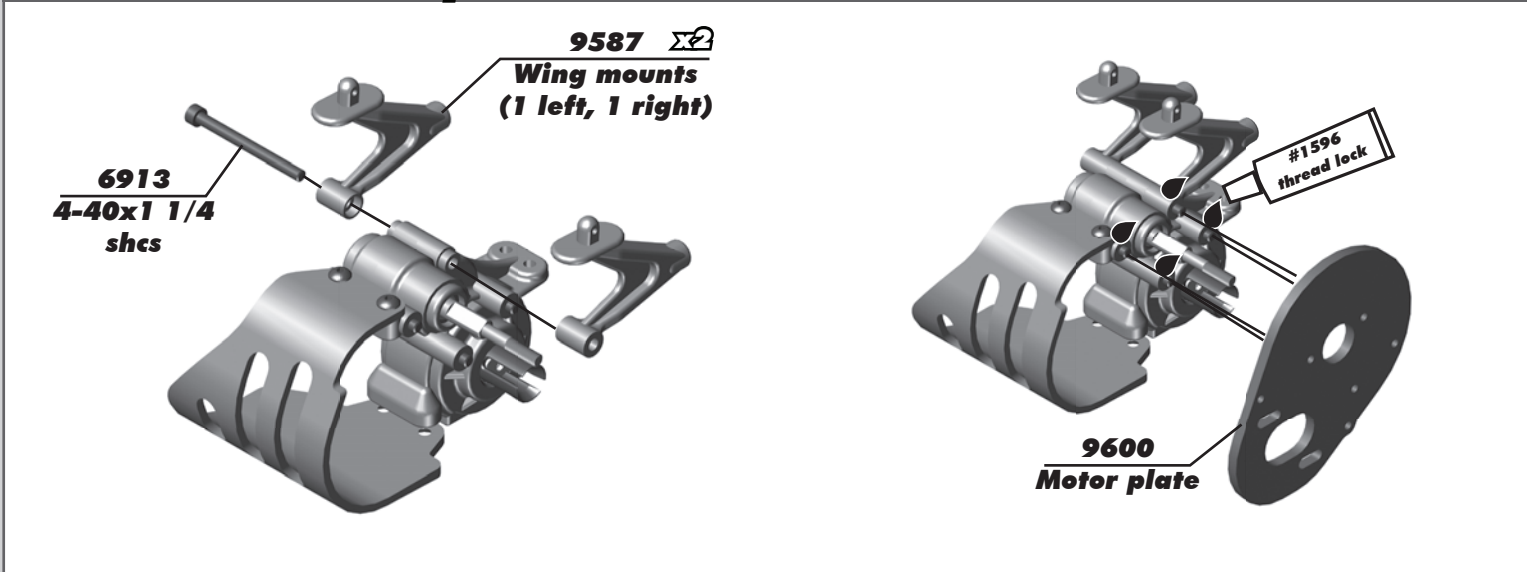

:: Transmission Build - Step 7



:: Rear End Build - Step 1

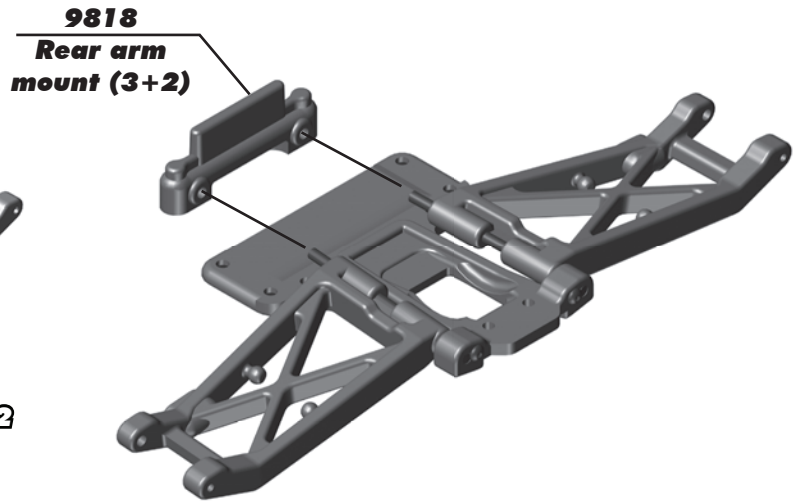
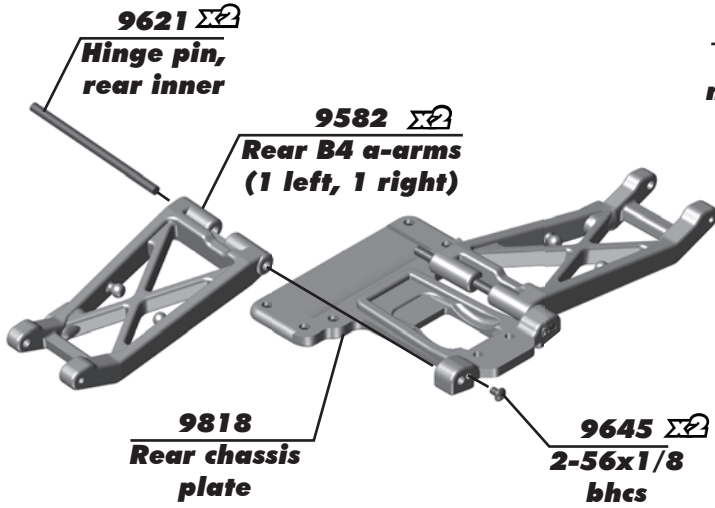

:: Rear End Build - Step 2

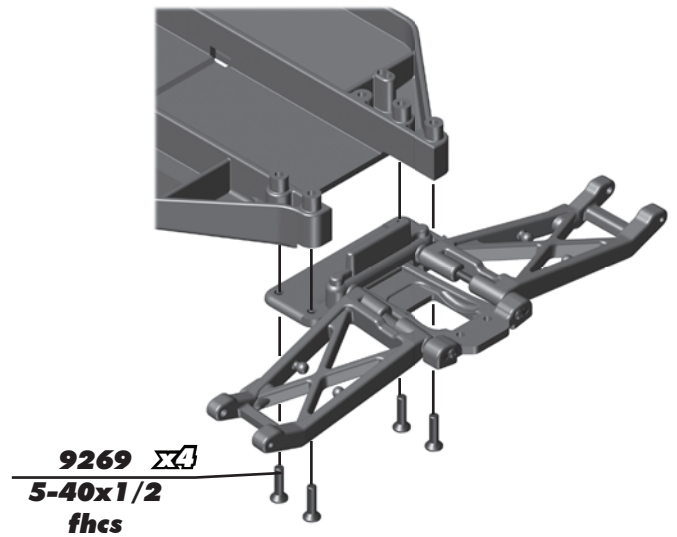
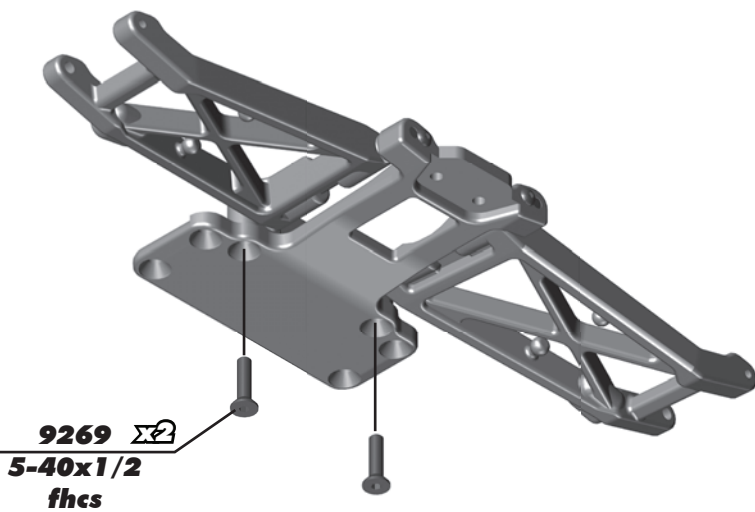

:: Rear End Build - Step 3

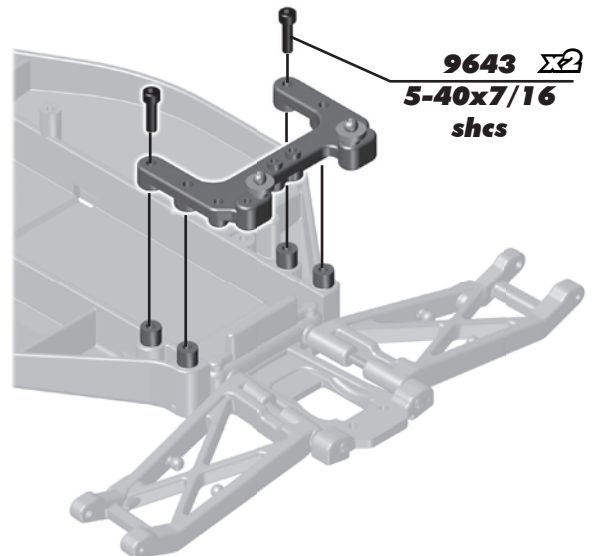
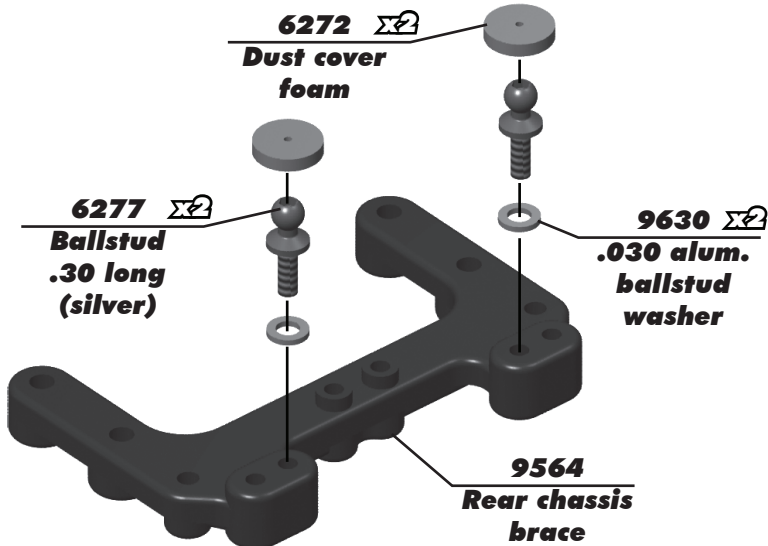

:: Rear End Build - Step 4

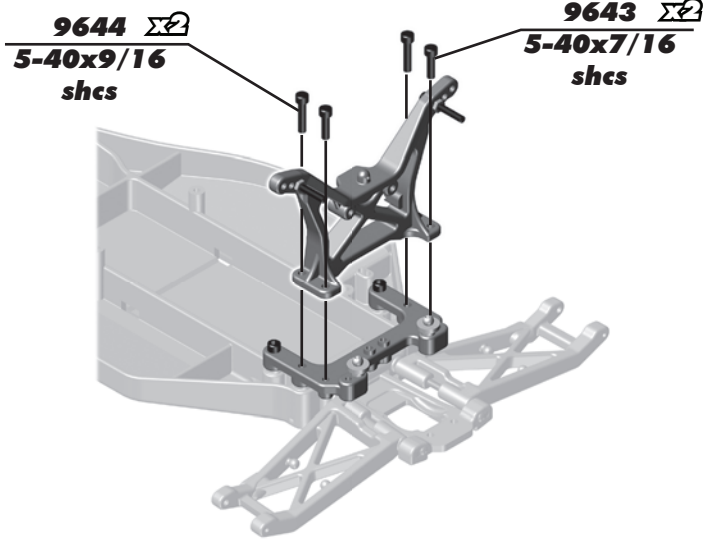
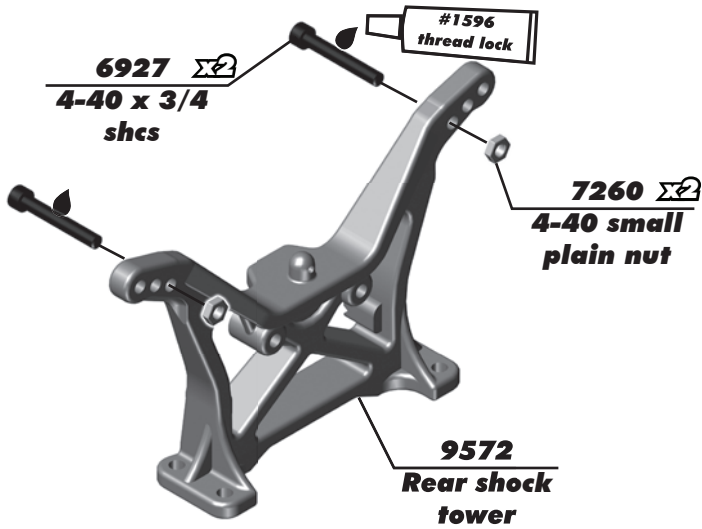

:: Rear End Build - Step 5

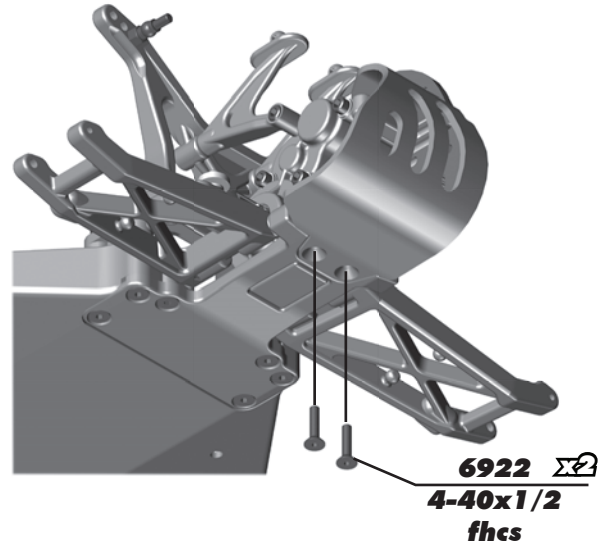
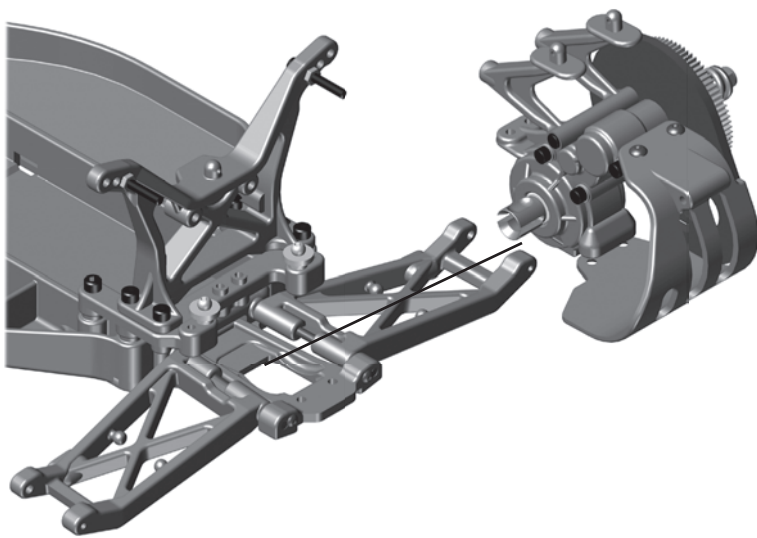

:: Rear End Build - Step 6

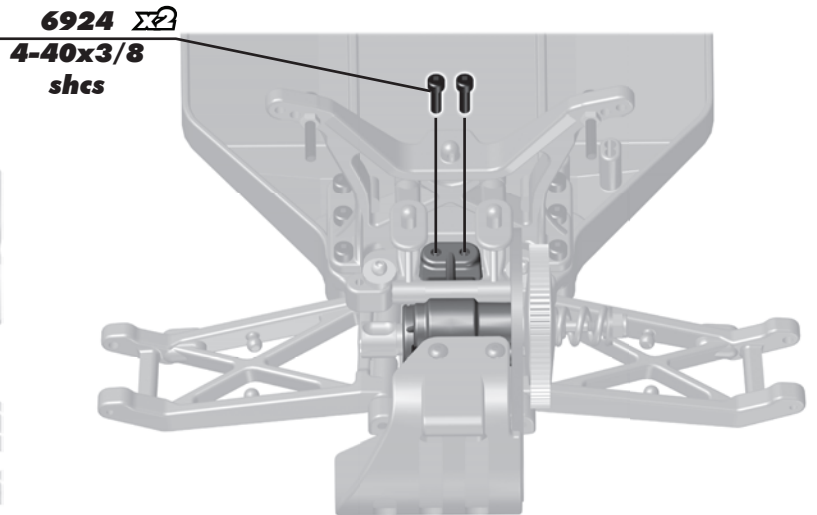
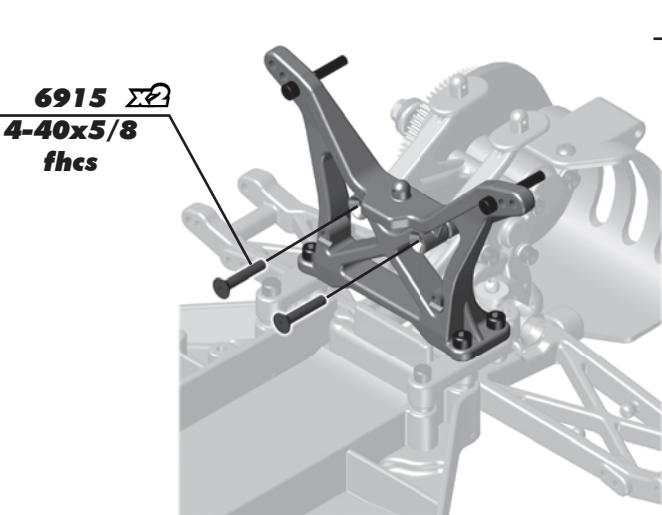

:: Rear Hub Build - Step 1

6272 Dust cover foam

3983 Ballstud .30 short (black)

9584 Rear hub carrier (left, right)

7260 4-40 small plain nut

3977 $\Sigma 2$ Ball bearing 3/16 x 3/8

7377 Bearing spacer

7368 3/16 axle shim

9670 Rear axle

7497 B4 wheel hex adapter (thick)

7369 1/16 universal roll pin

LEFT SIDE SHOWN

! Build left and right sides!

:: Rear Hub Build - Step 2

4187 $\Sigma 2$ Spacer

9671 B4 dogbone

5407 $\Sigma 2$ O-ring

Build x2 (right and left side)

9645 2-56x1/8 bhcs

9622 Hinge pin, rear outer

Build x2 (right and left side)

:: Rear Hub Build - Step 3

! Orient the notch to the left throughout the car. It indicates which end has the left hand threads!

Rear Camber Turnbuckle 1.28" (32.25mm)

7230 $\Sigma 2$ ball cup (large)

6263 2.06" turnbuckle

Build x2 (right and left side)

:: Shocks Build - Step 1

Front Shock

- 6469 Shock cap o-ring
- 9680 V2 RTR front shock body 0.89" stroke (blue)
- 7484 Shock internal spacer
- 5407 Red o-ring
- 7484 Lower shock seal cap

Rear Shock

- 6469 Shock cap o-ring
- 9681 V2 RTR rear shock body 1.18" stroke (blue)
- 7484 Shock internal spacer
- 5407 Red o-ring
- 7484 Lower shock seal cap

Piston

Remove spurs

Piston number here
Use #1 = front shocks
Use #1 = rear shocks

:: Shocks Build - Step 2

Front Shock

- 6465 Shock piston #1
- 6460 Shock shaft 0.71" stroke
- 6299 E-clip

Rear Shock

- 6465 Shock piston #1
- 6459 Shock shaft 1.02" stroke
- 6299 E-clip

:: Shocks Build - Step 3

Front Shock

- 7217 Eyelet
- 7217 Pivot ball

Rear Shock

- 4187 Downstop thin 1/32"
- 7217 Eyelet
- 7217 Pivot ball

:: Shocks Build - Step 4

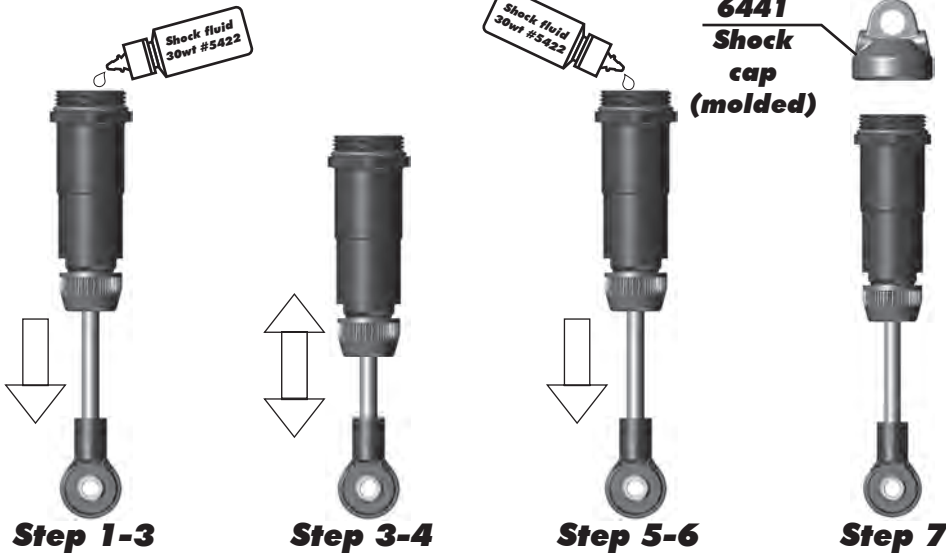

*** Shock Bleeding Steps:**

1. Pull shock shaft down.
2. Fill shock body 3/4 full with silicone fluid.
3. Slowly move the shock shaft up and down to remove air from under piston.
4. Wait for bubbles to come to surface.
5. Fill shock body to top with silicone fluid.
6. Place several drops of oil in the cap and on cap threads.
7. Install cap and tighten completely.
8. Slowly compress shaft all the way to the top. If there is pressure at the top of the stroke, there is too much oil or air. You must bleed it out.
9. Slowly pull shaft down.
10. Unscrew the cap 3/4 turn and tilt the shock at a slight angle.
11. Slowly compress the shaft to push out excess oil and air. You should see bubbles coming out from under the cap.
12. With the shaft compressed, tighten the cap and re-check for pressure at the top of the stroke. If there is still pressure, repeat steps 9 thru 11.

:: Shocks Build - Step 5

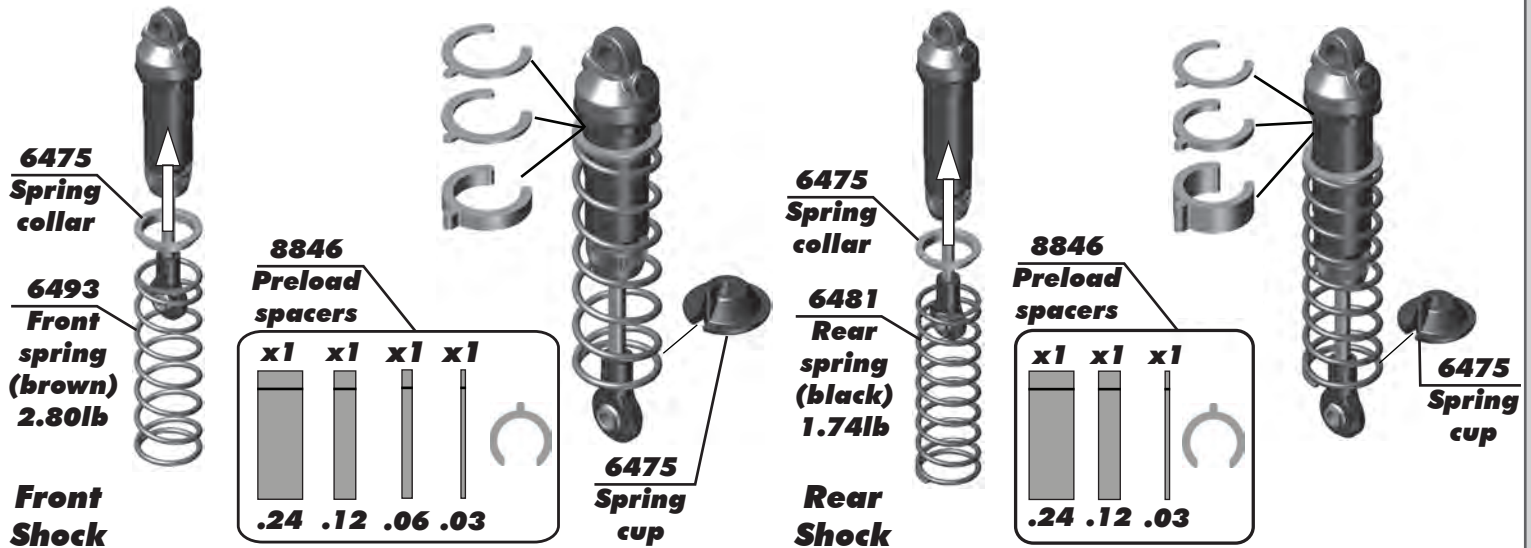

:: Shocks Build - Step 6

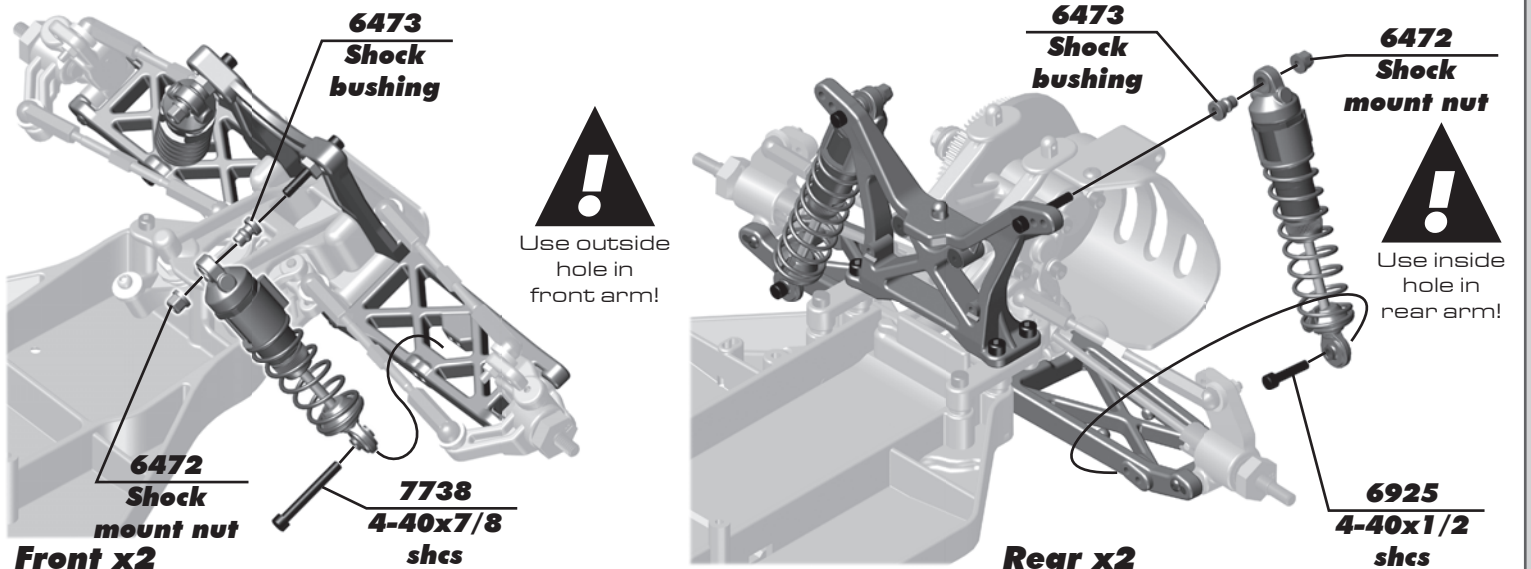

:: Electronics Build - Step 1

3981
Ballstud, .20
black, short

6272
Dust cover
foam

Servo

9180
Servo
horn
Screw supplied
with servo!

6917 $\Sigma 4$
4-40x3/8
bhcs

7336 $\Sigma 2$
Servo
mount

7336 $\Sigma 2$
Servo
spacers

7337 $\Sigma 4$
Gold
washer

Offset the servo horn by
5-10 degrees
(approximately one notch)

See page 19 for correct
servo spacing on the
servo chart!

:: Electronics Build - Step 2

9170
Servo link

Leave a
2mm gap!

6292 $\Sigma 2$
4-40x3/8
fhcs

:: Electronics Build - Step 3

Motor

6936 $\Sigma 2$
Washer #4
aluminum

31531 $\Sigma 2$
3x6mm
bhcs

8258
21T, 48P
pinion
(w/setscrew)

:: Electronics Build - Step 4

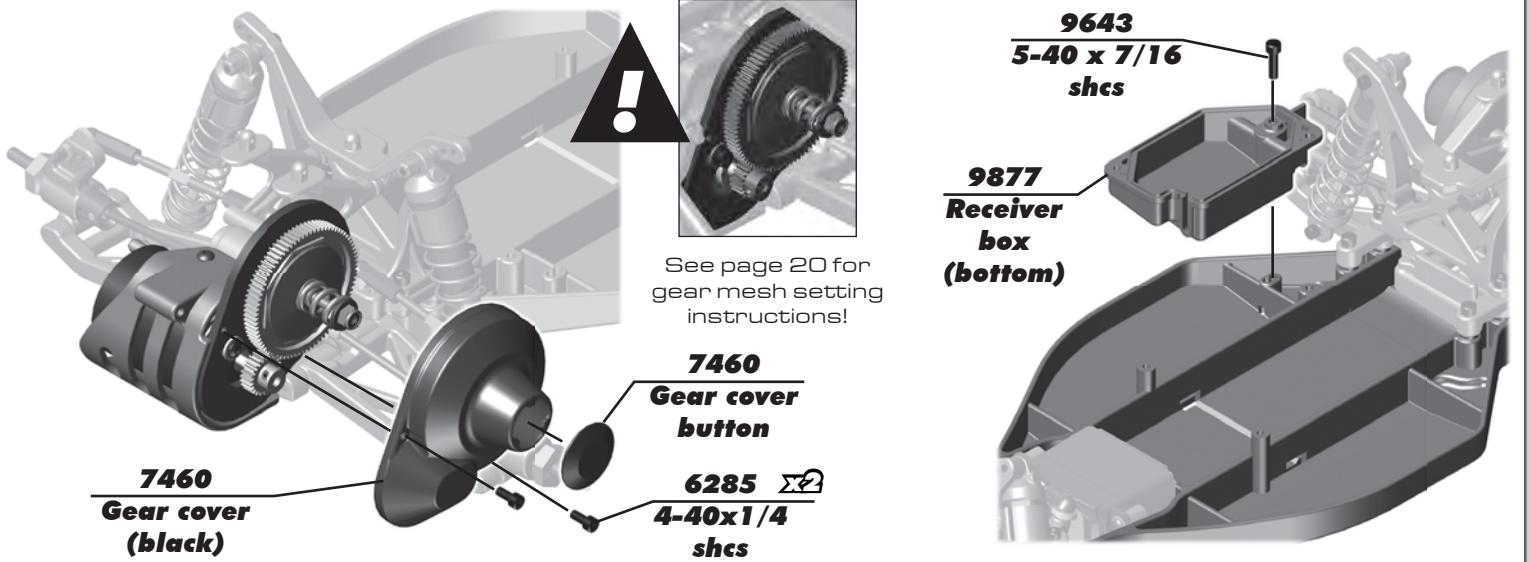

:: Electronics Build - Step 5



:: Electronics Build - Step 6



:: Electronics Build - Step 7

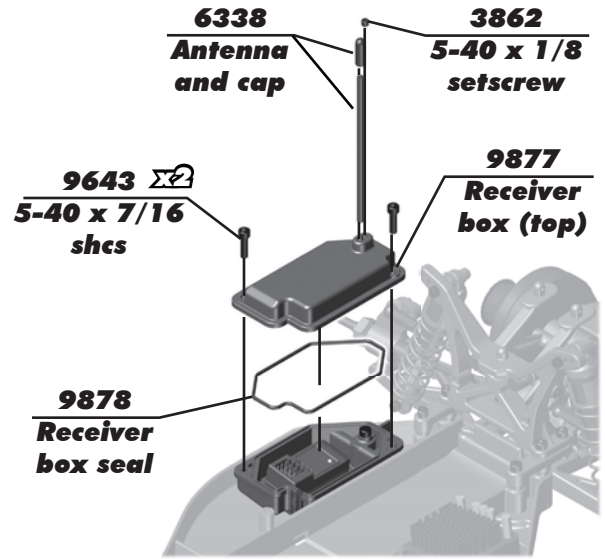
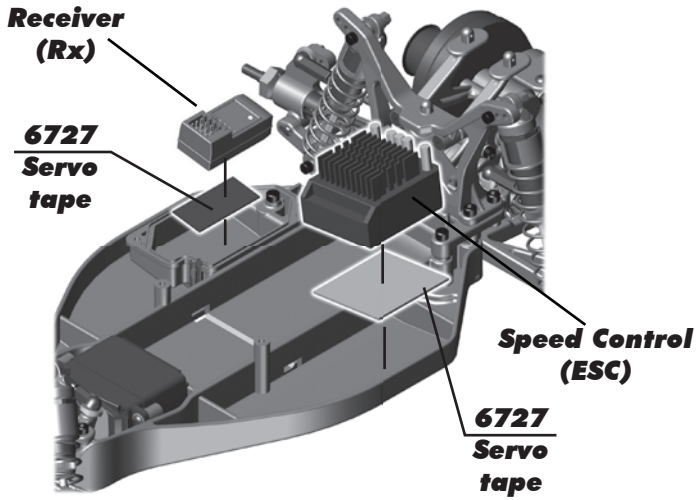

:: Electronics Build - Step 8

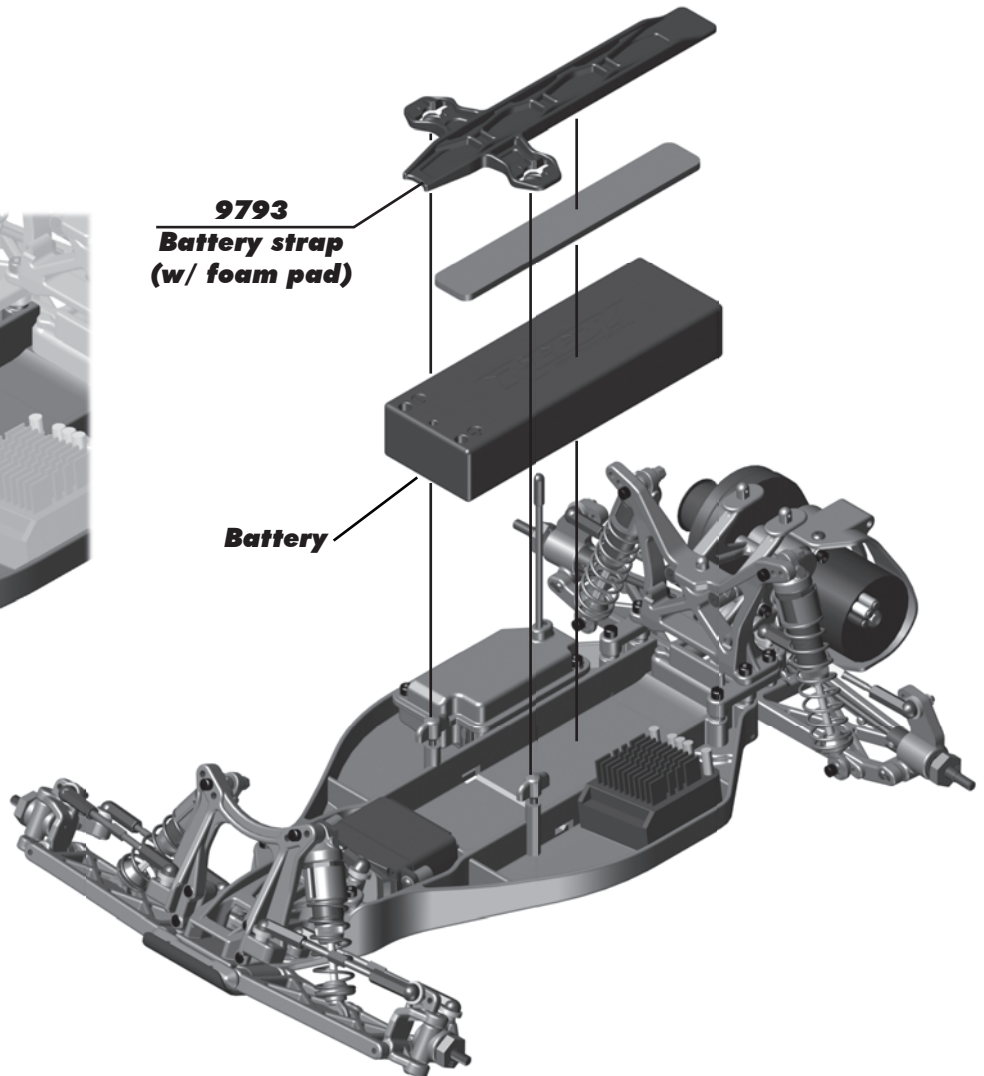
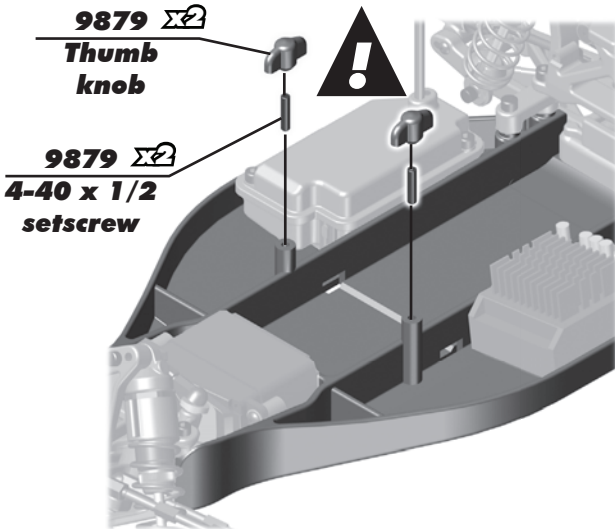
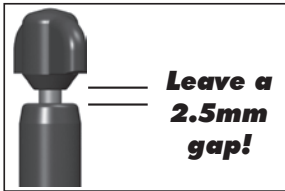

:: Electronics Build - Step 9

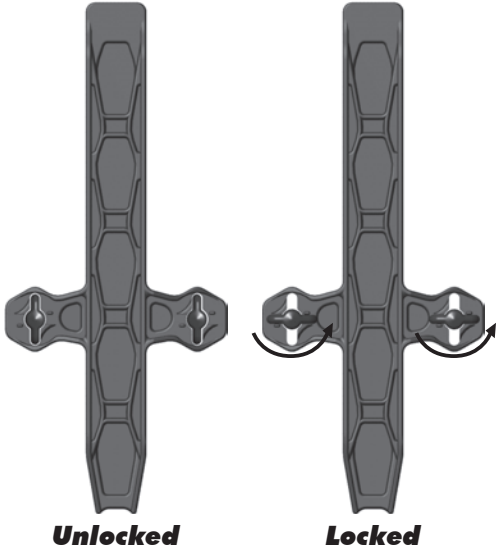

To remove your battery pack from the vehicle, twist the thumb knobs to the unlocked position, remove the battery strap, and then remove the battery. When you install the battery, make sure the thumb knobs are locked before operation.

You may need to adjust the height of the thumb knobs and/or the set screws that the thumb knobs are attached to for your specific battery pack type.

:: Wheels / Tires and Body - Step 1

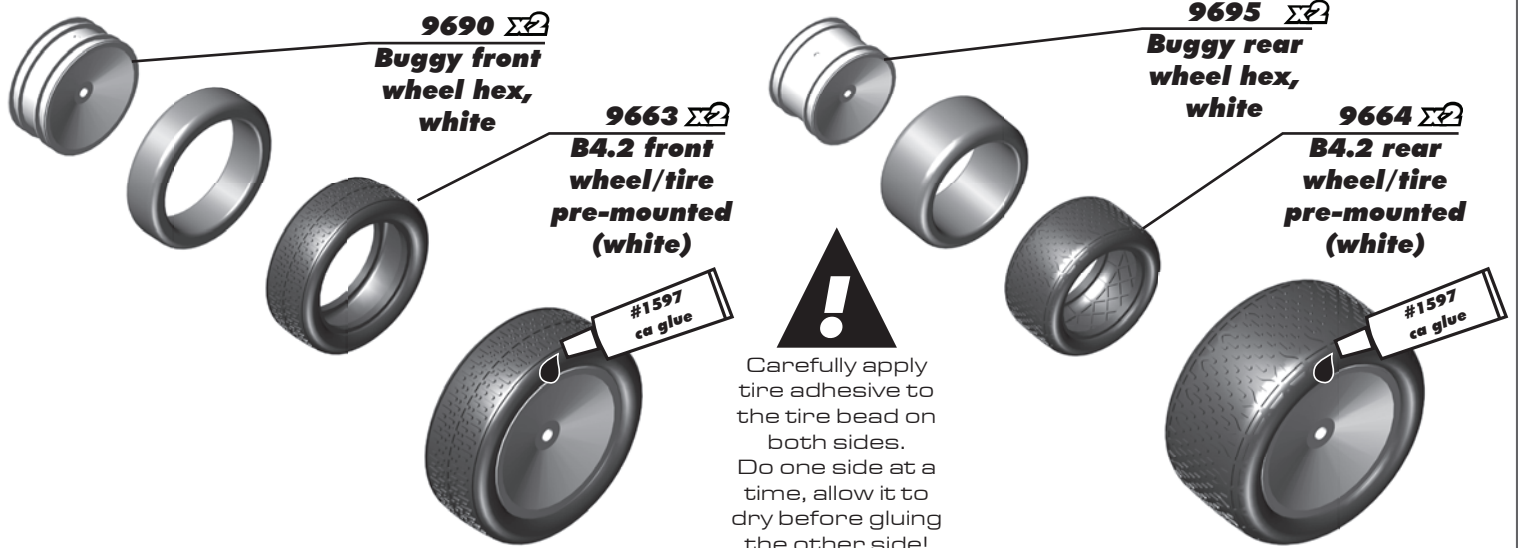

:: Wheels / Tires and Body - Step 2

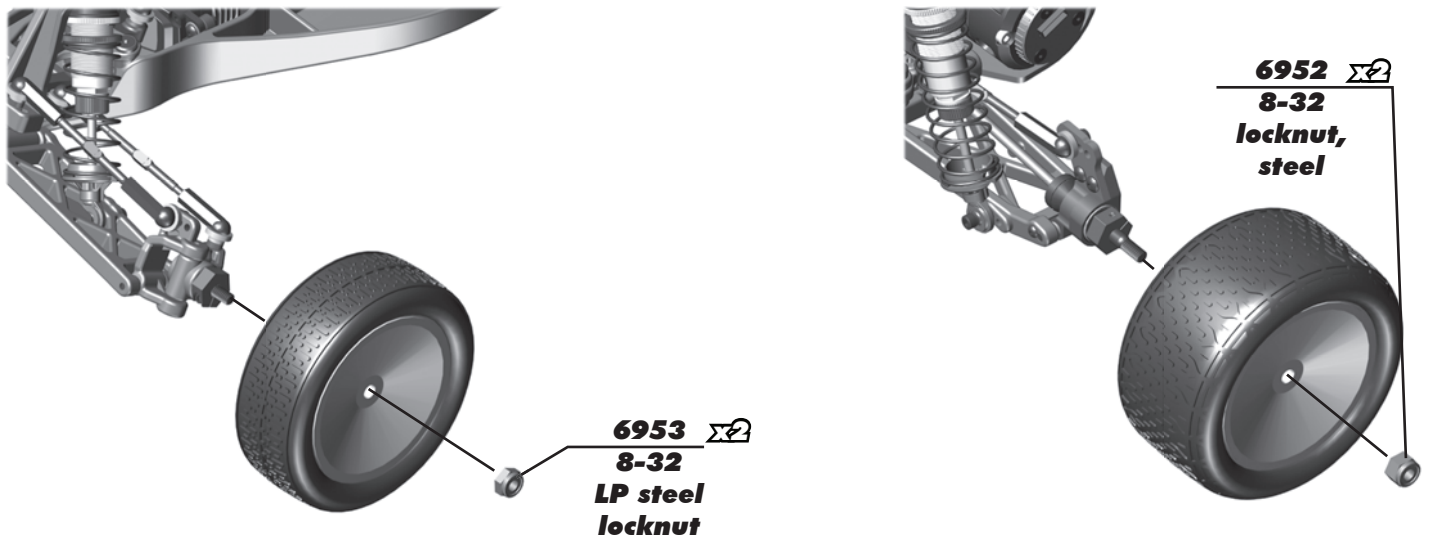

:: Wheels / Tires and Body - Step 3

6929
4-40x3/8
shcs
(w/hole)

RTR Body
(#9682 - Red)
(#9683 - Blue)

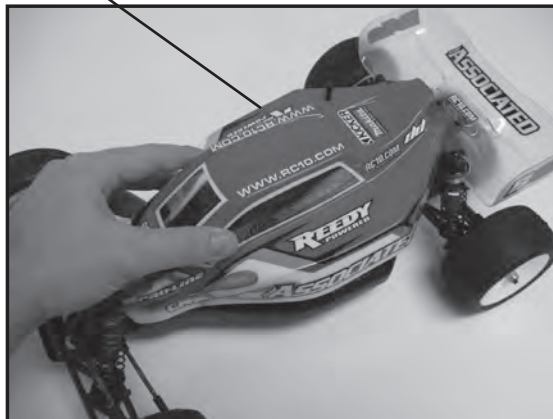
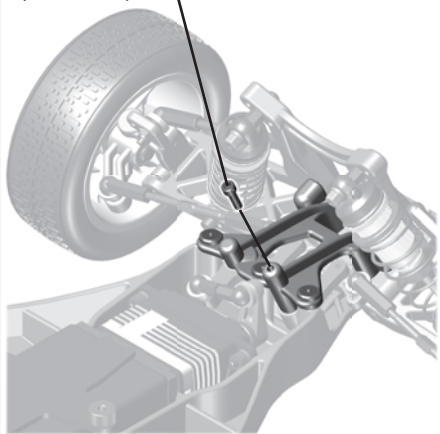

***Racers Tip:**
Instead of using the included body clips (#6332) and the #6929 SHCS for the top plate to install your body, you can use hook and loop tape on the inside of the body, and the sides of the chassis to keep your body in place!

:: Wheels / Tires and Body - Step 4

9587 
Wing
shims

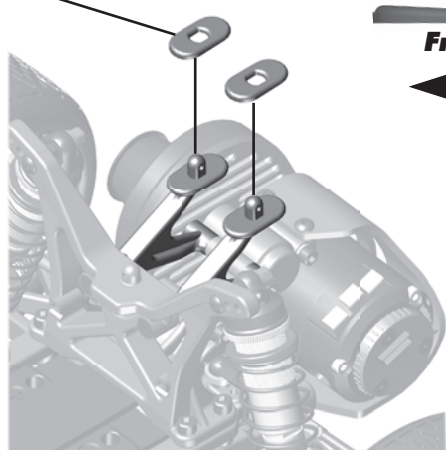

RTR Wing
(#9682 - Red)
(#9683 - Blue)

6332 
Body
clips

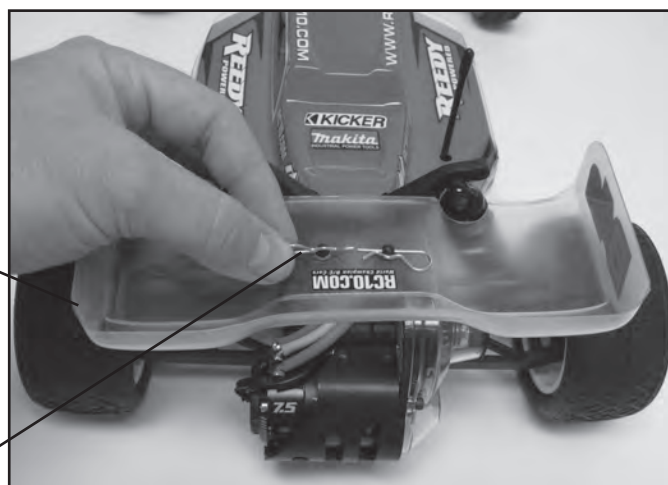

:: Servo Chart

Steering Servo Chart

		# 9180 servo arm 
Associated	XP-1015, XP-1313	F
Airtronics	94102	A
Airtronics	94257, 94258, 94357, 94358, 94452, 94453, 94755	A
Hitec	HS-5625MG, HS-5645MG, HS645MG	H
Hitec	HS-965, HS-985MG, HS-5965, HS-5985MG	H
JR	Z4750, Z2750	J
JR	Z250, Z550	J
Futaba	S9204, S9250, S9450	F
Futaba	S9404	F
KO	PS-401, PS-2001, PS-2004, PS-2015, PS-2173, PS-2174, PS-2123, PS-2143, PS-2144	J

* Not all servo's are listed
* Make sure servo linkage clears the servo through full travel in both directions.
Use #7336 servo spacers to adjust the servos position
(to make the steering link as straight as possible)

:: Tuning Tips

Tips for Beginners:

Before making any changes to the standard setup, make sure you can get around the track without crashing. Changes to your vehicle will not be beneficial if you can't stay on the track. Your goal is consistent laps.

Once you can get around the track consistently, start tuning your vehicle. Make only ONE adjustment at a time, testing it before making another change. If the result of your adjustment is a faster lap, mark the change on the included setup sheet (make additional copies of the sheet before writing on it). If your adjustment results in a slower lap, revert back to the previous setup and try another change.

When you are satisfied with your vehicle, fill in the setup sheet thoroughly and file it away. Use this as a guide for future track days or conditions.

Periodically check all moving suspension parts. Suspension components must be kept clean and move freely without binding to prevent poor and/or inconsistent handling.

Motor Gearing:

Proper motor gearing will result in maximum performance and run time while reducing the chance of overheating and premature motor failure. The gear ratio chart lists recommended starting gear ratios for the most widely used motor types. Gear ratios will vary depending upon motor brand, wind, and electronic speed control. Consult your motor and electronic speed control manufacturers for more information. Team Associated is not responsible for motor damage due to improper gearing. * These gearings are for use with advanced timing speed control settings!

B4.2 Gear Ratio Chart (Internal Gear Ratio 2.60:1)

Motor	Pinion	Spur	FDR
27T Reedy Stock	23	81	9.15:1
19T Reedy Super Stock	22	81	9.57:1
17.5 Reedy Sonic Brushless *	23	78	8.82:1
17.5 Reedy Sonic Brushless	32	75	6.09:1
13.5 Reedy Sonic Brushless *	22	81	9.57:1
13.5 Reedy Sonic Brushless	30	75	6.50:1
10.5 Reedy Sonic Brushless	24	81	8.78:1
9.5 Reedy Sonic Brushless	23	81	9.15:1
8.5 Reedy Sonic Brushless	22	81	9.57:1
7.5 Reedy Sonic Brushless	21	81	10.02:1
6.5 Reedy Sonic Brushless	21	81	10.02:1
3300kV Brushless	21	81	10.02:1
3900kV Brushless	21	81	10.02:1
4900kV Brushless	19	81	11.08:1
6100kV Brushless	18	81	11.70:1

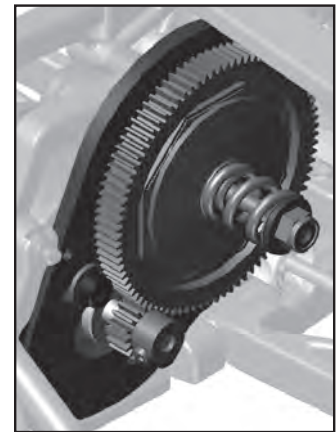

Set The Gear Mesh:

You should be able to rock the spur gear back and forth in the teeth of the pinion gear without making the pinion gear move. If the spur gear mesh is tight, then loosen the #31532 screws and move the motor away, then try again. A gear mesh that is too tight or too loose will reduce power and damage the gear teeth.

Motor Maintenance:

Brushed motors require frequent maintenance to keep performance levels at their maximum. Between runs and after letting the motor cool completely, inspect the brushes to ensure that they are moving freely in their holders.

Remove the springs and slide the brushes in and out of their holders checking for any resistance or rough spots.

If found, remove the brush and carefully wipe it clean. Removing buildup will allow the brush to slide freely and create maximum contact with the commutator resulting in maximum power output.

After every 3-5 runs, remove the brushes from their holders and inspect the tips for wear or burning. If there is noticeable wear (less than 75% of the brush remaining), it is best to cut the commutator and replace the brushes with a new pair. If the tips become a burned blue color, the lubricant in the brush has been burned away and new brushes should be installed.

Occasionally, the motor should be cleaned with a soft brush to prevent dirt build up around the brush hood area and ball bearings. At this time, it is a good idea to add one drop of bushing / bearing oil to each bushing or ball bearing.

If using a brushless motor, please refer to the motor manufacturer's guidelines for proper maintenance.

Slipper Clutch:

The assembly instructions give you a base setting for your clutch. Turn the nut on the shaft so that the end of the top shaft is even with the outside of the nut. At the track, tighten or loosen the nut in 1/8 turn increments until you hear a faint slipping sound for 1-2 feet on takeoffs. Another popular way to set the clutch is to hold both rear tires firmly in place and apply short bursts of throttle. If the clutch is properly set, the front tires should lift slightly up off the surface.

:: Tuning Tips (cont.)

Front Camber Links:

Changing the length of the camber link is considered a bigger step than adjusting the ball end height on the tower. Shortening the camber link (or lowering the ball end) will give the front end less roll and quicken steering response. Lengthening the camber link (or raising the ball end) will give the front more roll and slower steering response. Longer camber links are typically used on high grip tracks and shorter links tend to work better on medium-grip loose tracks.



*Raise or lower the ball end by adding or subtracting washers here

Front Camber:

Camber describes the angle at which the tire and wheel rides when looked at from the front. Negative camber means that the tire leans inward at the top. A good starting camber setting is -1° . Use the included #1719 camber gauge to set your camber. Positive camber, where the top of the tire is leaning out, is not recommended.



*Testing camber with camber gauge

Caster:

Caster describes the angle of the kingpin as it leans toward the rear of the vehicle. Positive caster means the kingpin leans rearward at the top. The supplied 30° caster blocks (#7922) are recommended in most cases. For less corner entry steering and more exit steering, try the optional 25° blocks (#7919).

Rear Camber Link:

Changing the length of the camber link is considered a bigger step than adjusting the ball end height on the rear chassis brace. Shortening the camber link (or lowering the ball end) will give the rear end less roll and the car will tend to accelerate or "square up" better. Lengthening the camber link (or raising the ball end) will give the rear more roll and more cornering grip. Longer camber links are typically used on high grip tracks, while shorter links tend to work better on medium grip loose tracks. The kit setting is the best compromise of cornering grip and acceleration.

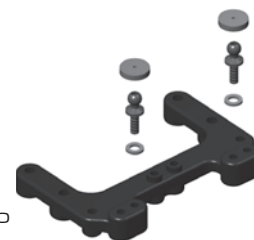

*Raise or lower the ball end by adding or subtracting washers here

Rear Camber:

Camber describes the angle at which the tire and wheel rides when looked at from the back. Negative camber means that the tire leans inward at the top. A good starting camber setting is -1° . Use the included #1719 camber gauge to set your camber. Adding a small amount of positive camber, where the top of the tire is leaning out, will tend to improve straight-line acceleration on loose tracks.

Ride Height:

Ride height is the distance from the ground to the bottom of the chassis. The standard front ride height setting is with the front arms level (referred to as "arms level") or 24mm (Ride Height Gauge #1449). Check the ride height by lifting up the entire car about 8-12 inches off the bench and drop it. After the suspension "settles" into place, measure ride height (Ride Height Gauge #1449). Raise or lower the shock collars as necessary so that the left & right arms appear to be level.

The rear ride height setting you should use most often is with the outdrive, driveshaft, and axles all on the same imaginary horizontal line (referred to as "bones level") or 24mm (Ride Height Gauge #1449). Check the ride height by lifting up the entire car about 8-12 inches off the bench and drop it. After the suspension "settles" into place, measure ride height (Ride Height Gauge #1449). Raise or lower the shock collars as necessary so that the left & right driveshafts appear to be level.

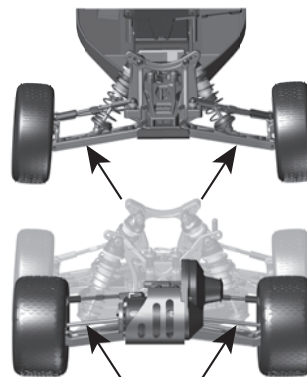

*Front arms should be in a straight line when ride height is set at "arms level"



*CVA bones should be in a straight line when ride height is set at "CVA bones level"

Wheelbase Adjustment:

You have three options for rear hub spacing, Forward, Middle, & Back. The kit setting provides the most rear traction, and will be used most often. For improved handling in bumps or rhythm sections, try moving the hubs to the Middle or Back position. This can also make the car handle better in 180° turns.

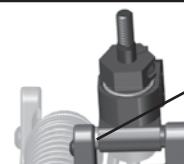

*Spacers to the rear will place hubs forward, shortening the wheelbase

Anti-Roll Bars:

The optional #9635 rear anti-roll bar kit (also called the "swaybar") allows you to add roll resistance to the rear end with minimal effect on handling over bumps and jumps. It is an especially helpful tuning item on high-grip tracks (try the gold bar). The silver and black anti-roll bars are typically used on medium-grip loose tracks.

:: Shocks

5407	Red O-Rings	8
6299	1/8" E-Clips	12
6441	Shock Cap, Molded	4
6459	Shock Shaft, 1.02" stroke	1
6460	Shock Shaft, 0.71" stroke	1
6465	Shock Pistons, 4 each	1
6466	Shock Down Stops, Set	1
6469	Black Shock Cap O-Ring	4
6473	Shock Bushings	4
6475	Preload Spacers 5 thicknesses, Collars & Cups, 4 each	1
6925	4-40 x 1/2" SHCS	6
7217	Shock Rod Ends / Plastic Pivot Balls	2
7484	V2 1/10 Shocks Rebuild Kit	1
7738	4-40 x 7/8" SHCS	6
8846	Preload Spacers, 4 each	1
9680	V2 RTR Front Shock Bodies 0.89"	Pr.
9681	V2 RTR Rear Shock Bodies 1.18"	Pr.



:: Springs

1581	Factory Team Buggy Front Spring Kit. 1 pr 1 of green, silver, blue, black front springs	1
1582	Factory Team Truck Rear Spring Kit. 1 pr of 1 green, silver, blue, gold, red rear springs	1
6493	Front Buggy Spring Brown 2.80 lb (Kit)	Pr.
6494	Front Buggy Spring Green 3.50 lb	Pr.
6496	Front Buggy Spring Silver 3.85 lb	Pr.
6497	Front Buggy Spring Blue 4.20 lb	Pr.
8232	Front Buggy Spring Black 3.20 lb	Pr.
6478	Rear Spring Silver 2.10 lb	Pr.
6480	Rear Spring Green 1.90 lb	Pr.
6481	Rear Spring Black 1.74 lb (Kit)	Pr.
6482	Rear Spring Gray 2.33 lb	Pr.
7434	Rear Spring Blue 2.55 lb	Pr.
7435	Rear Spring Gold 2.75 lb	Pr.
7436	Rear Spring Red 2.95 lb	Pr.

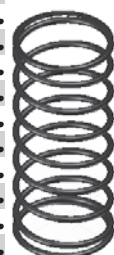

:: Shock Fluid

5420	10 Weight Silicone Shock Fluid	2oz.
5421	20 Weight Silicone Shock Fluid	2oz.
5422	30 Weight Silicone Shock Fluid	2oz.
5423	40 Weight Silicone Shock Fluid	2oz.
5424	22.5 Weight Silicone Shock Fluid	2oz.
5425	80 Weight Silicone Shock Fluid	2oz.
5426	27.5 Weight Silicone Shock Fluid	2oz.
5427	15 Weight Silicone Shock Fluid	2oz.
5428	25 Weight Silicone Shock Fluid	2oz.
5429	35 Weight Silicone Shock Fluid	2oz.
5430	45 Weight Silicone Shock Fluid	2oz.
5431	55 Weight Silicone Shock Fluid	2oz.
5432	32.5 Weight Silicone Shock Fluid	2oz.
5433	37.5 Weight Silicone Shock Fluid	2oz.
5434	42.5 Weight Silicone Shock Fluid	2oz.
5435	50 Weight Silicone Shock Fluid	2oz.
5436	60 Weight Silicone Shock Fluid	2oz.
5437	70 Weight Silicone Shock Fluid	2oz.
5438	47.5 Weight Silicone Shock Fluid	2oz.



:: Optional Ball Differential

6573	Diff Thrust Washer & Bolt	2
6574	Precision Diff Thrust Balls, 5/64"	6
6575	Locking T-Nut, Diff Thrust Bolt, & Cover	1
6581	3/32" Carbide Diff Balls	12
6582	Diff Thrust Spring	1
6589	Ball Bearing, 5/32 x 5/16" unflanged	2
7664	Diff Gear 52T	1
7666	Diff Drive Rings, 2.60:1	2
7677	B4 / T4 / GT Diff Rebuild Kit	1
9852	SC10 Ball Diff Outdrives	1
9853	SC10 Complete Ball Differential	1

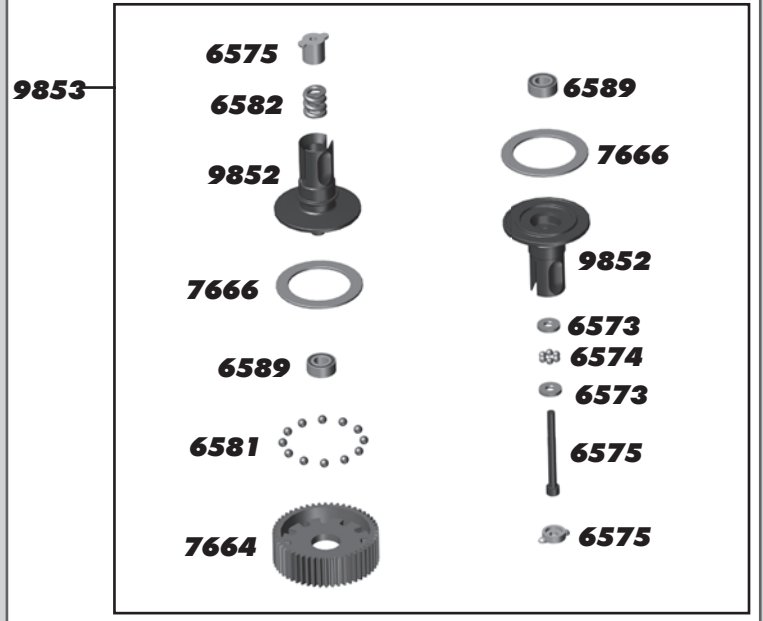

:: Slipper Clutch / Pinions

6285	4-40 x 1/4 SHCS	12	8253	16T 48P Pinion Gear	1
6629	5-40 Locknuts	6	8254	17T 48P Pinion Gear	1
7460	Molded B4/T4 Gear Cover, black (Kit)	1	8255	18T 48P Pinion Gear	1
7461	Molded B4/T4 Gear Cover, clear	1	8256	19T 48P Pinion Gear	1
9603	B4/T4 Slipper Pad	2	8257	20T 48P Pinion Gear	1
9604	Slipper Plate	1	8258	21T 48P Pinion Gear (Kit)	1
9605	Slipper Spring	1	8259	22T 48P Pinion Gear	1
9650	75T 48P Spur Gear	1	8260	23T 48P Pinion Gear	1
9651	81T 48P Spur Gear (Kit)	1	8261	24T 48P Pinion Gear	1
9652	78T 48P Spur Gear	1	8263	26T 48P Pinion Gear	1
9653	84T 48P Spur Gear	1	8264	27T 48P Pinion Gear	1
9654	87T 48P Spur Gear	1	8265	28T 48P Pinion Gear	1
			8266	29T 48P Pinion Gear	1
			8267	30T 48P Pinion Gear	1
			8268	31T 48P Pinion Gear	1
			8269	32T 48P Pinion Gear	1
			8270	33T 48P Pinion Gear	1
			8271	34T 48P Pinion Gear	1
			8272	35T 48P Pinion Gear	1

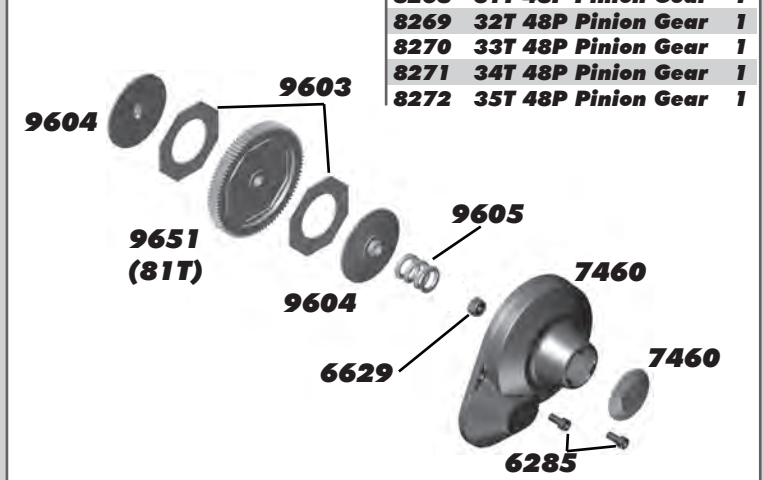

:: Gear Differential

9827	Complete Gear Diff	1
9828	Diff Gear and Cover	1
9829	Gear Diff Rebuild	1
9830	Gear Diff Outdrives, Set	1
9831	Gear Diff O-Ring Set	1
9832	10x16mm Bearing	2
9888	0.5mm Gear Diff Shim	2

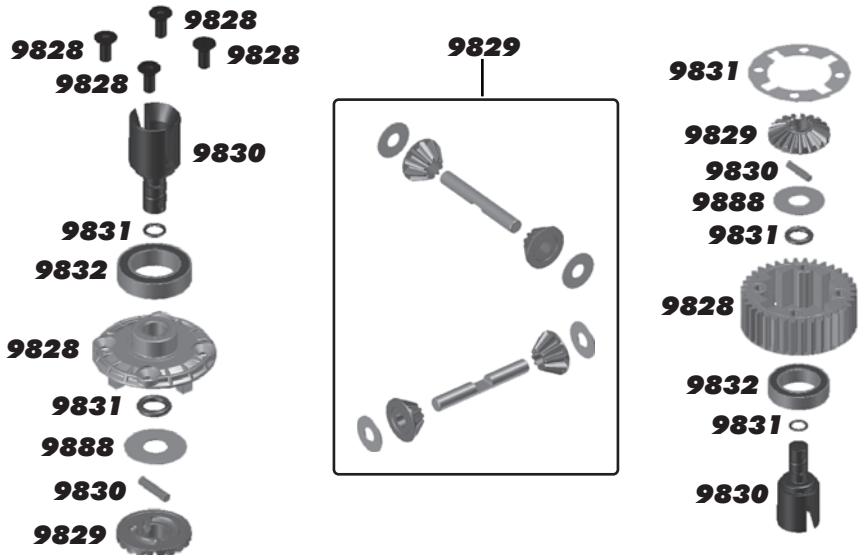

:: Differential Fluids

5450	Silicone Diff Fluid 1,000CST	1
5451	Silicone Diff Fluid 2,000CST	1
5452	Silicone Diff Fluid 3,000CST	1
5453	Silicone Diff Fluid 5,000CST	1
5454	Silicone Diff Fluid 7,000CST	1
5455	Silicone Diff Fluid 10,000CST	1
5456	Silicone Diff Fluid 20,000CST	1
5457	Silicone Diff Fluid 30,000CST	1
5458	Silicone Diff Fluid 60,000CST	1
5459	Silicone Diff Fluid 100,000CST	1



:: Turnbuckles / Servo

3981	Ballstud .20" Black (short)	6
6263	Turnbuckle, 2.06"	2
6272	Foam Ballend Dust Cover	28
6292	4-40 x 3/8" FHCS	6
6917	4-40 x 3/8" BHCS	6
7230	Ballcups, large	12
7336	Servo Mount Set	1
7337	Gold Washer	4
9170	B4 / T4 Servo Link	1
9180	Servo Horns Set	1

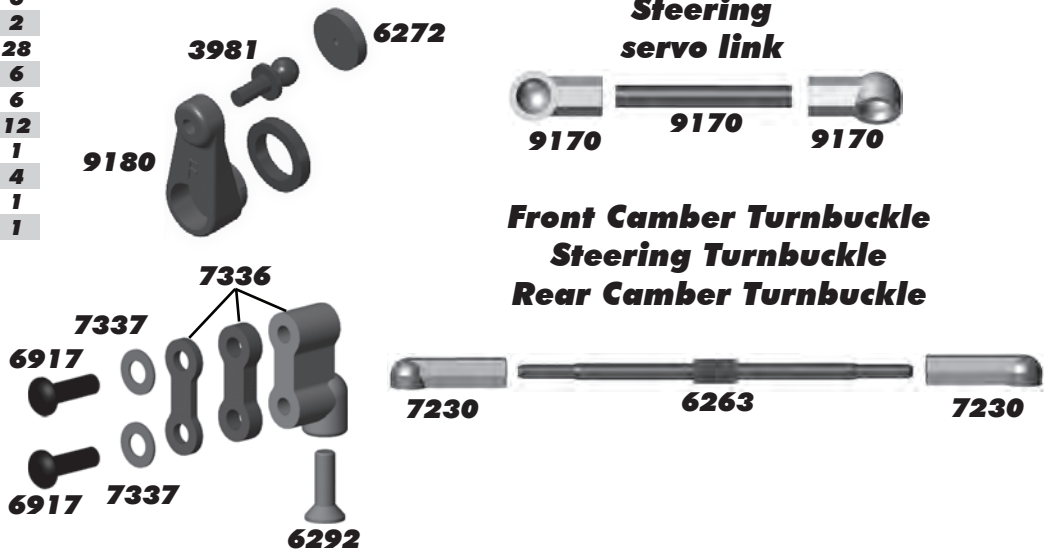

:: Battery Strap

9238	Foam Battery Spacers, Set	1
9793	B4.1 RTR Battery Strap Set	1

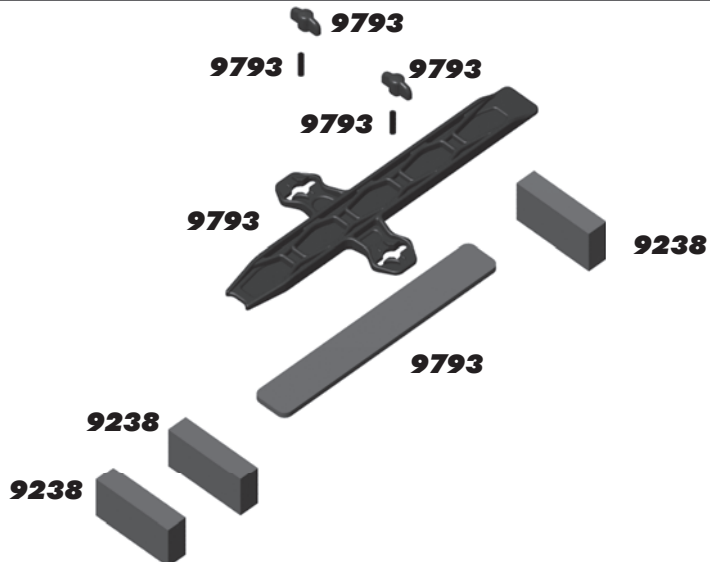

:: Front Arm

3977	Ball Bearing 3/16" x 3/8"	2
3983	Ballstud .30" Black (short)	6
4187	.030 Nylon Washers	12
4449	4-40 Aluminum Locknut	5
6272	Foam Ballend Dust Covers	28
6277	Ballstud .30 Silver (short)	4
6925	4-40 X 1/2" SHCS	6
6953	8-32 Low Profile Locknut, steel	6
7260	4-40 Plain Nut	12
7369	1/16" Universal Roll Pins	4
7496	B4 Front Axle, hex	2
7497	B4 Wheel Hex Adapter Set	1
9578	Front A-Arm B4	Pr.
9580	Caster Block, 25° (left & right)	Pr.
9621	Inner Hinge Pin Set	1
9622	Outer Hinge Pin Set	1
9645	2-56 x 1/8" BHCS	8
9880	Steering Block, Hex	Pr.
9882	C-Clip, 3/16"	6

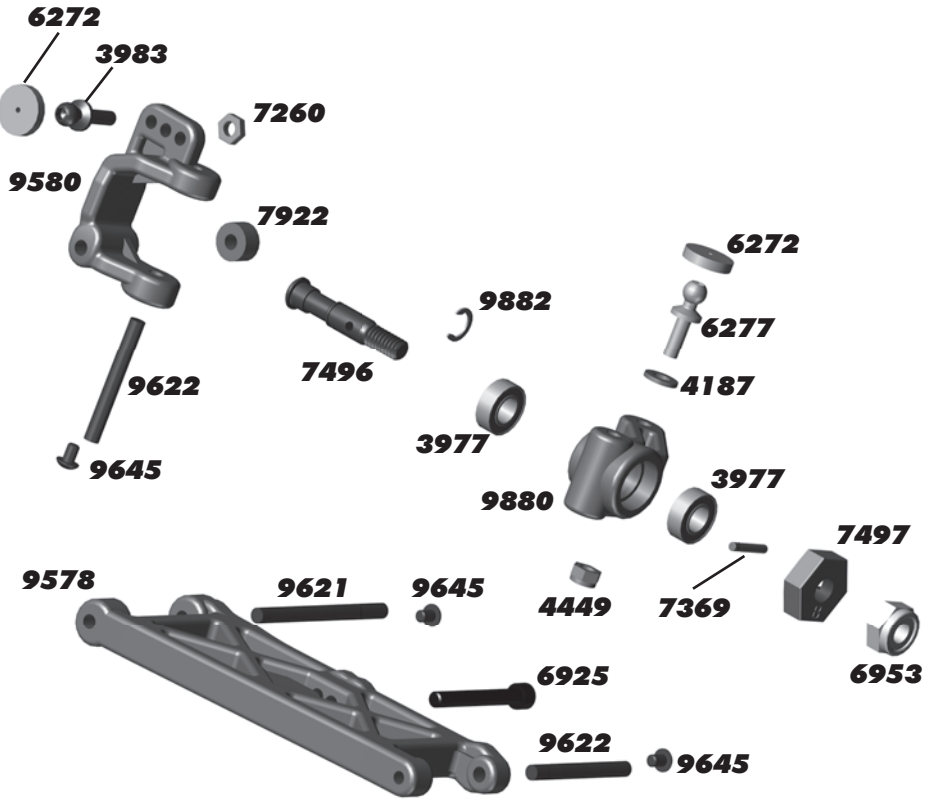

:: Rear Arm

3977	Ball Bearing 3/16 x 3/8"	2
3983	Ballstud .30" Black (short)	6
4187	.030 Nylon Washers	12
5407	Red O-Ring	8
6272	Foam Ballend Dust Cover	28
6952	8-32 Locking Nut, Steel	6
7260	4-40 Plain Nut	12
7368	3/16" Axle Shims	14
7369	1/16" Axle Roll Pins	4
7497	B4 Wheel Hex Adapter Set	1
9582	B4 Rear A-Arms (L&R)	Pr.
9584	B4 / T4 RR Hub Carrier (L&R)	Pr.
9622	B4 Outer Hinge Pin Set	1
9645	2-56 x 1/8" BHCS	8
9670	3/16" Rear Axle	1
9671	B4 RTR Dogbone	1

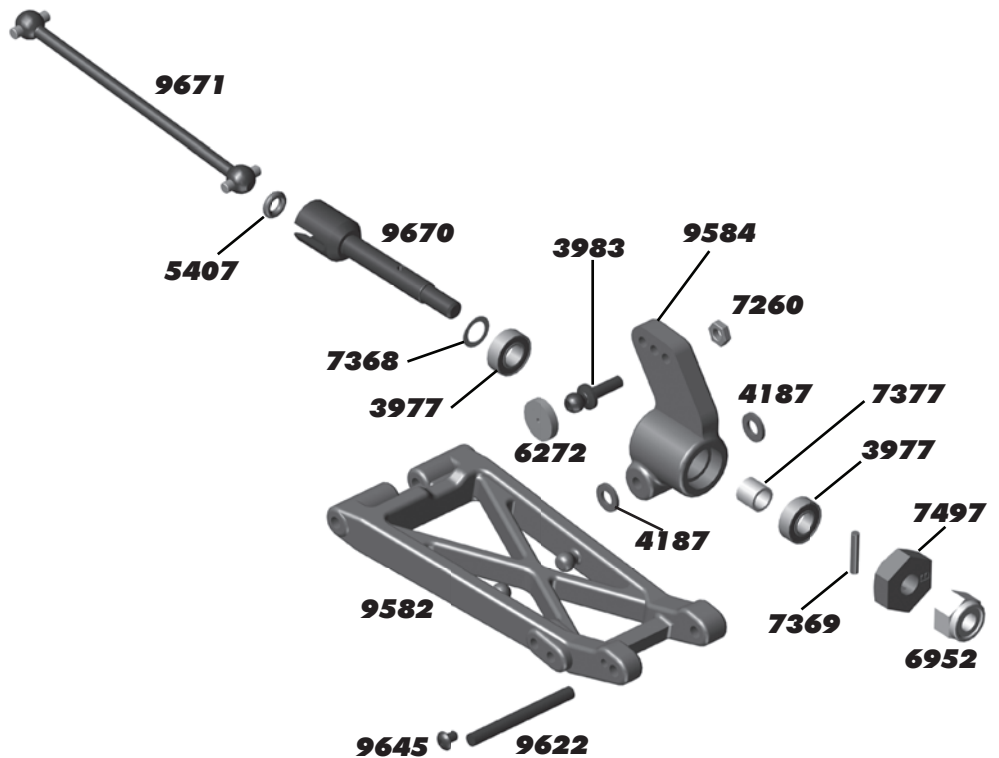

:: Front Shock Tower

6272	Foam Ballend Dust Covers	28
6277	Ballstud .30 Silver (short)	4
6472	4-40/5-40 Plastic Nut	4
6473	Shock Bushing	4
6924	4-40 x 3/8" SHCS	6
7738	4-40 x 7/8" SHCS	6
9568	B4 Front Shock Tower	1
9630	Ballstud Washer	10

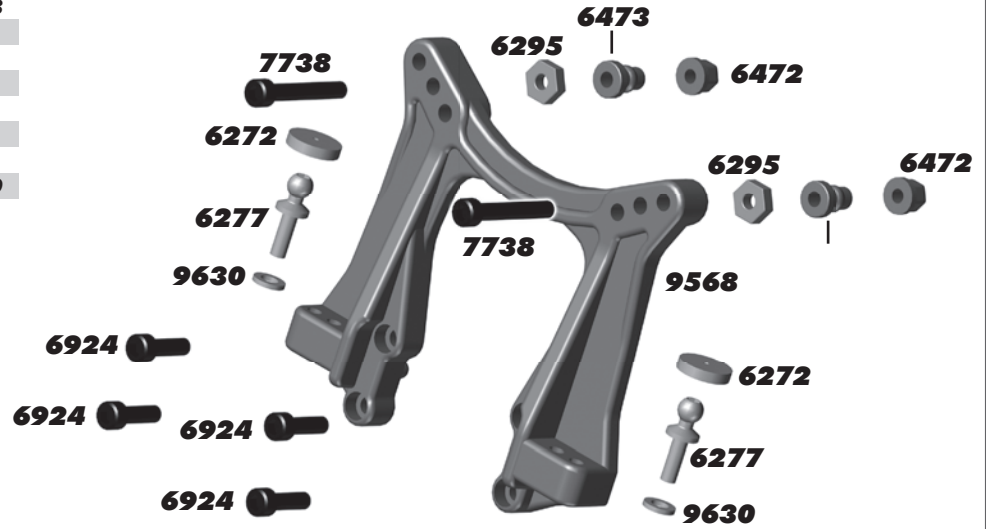

:: Rear Shock Tower

6332	Body Clips	6
6472	4-40/5-40 Plastic Nut	4
6473	Shock Bushing	4
6915	4-40 x 5/8" FHCS	6
6927	4-40 x 3/4" SHCS	6
7413	4-40 x 3/4 BHCS	6
9572	B4 Rear Shock Tower	1
9587	B4 / T4 Wing Mount / Shim Set	1
9643	5-40 x 7/16" SHCS	6
9644	5-40 x 9/16" SHCS	6

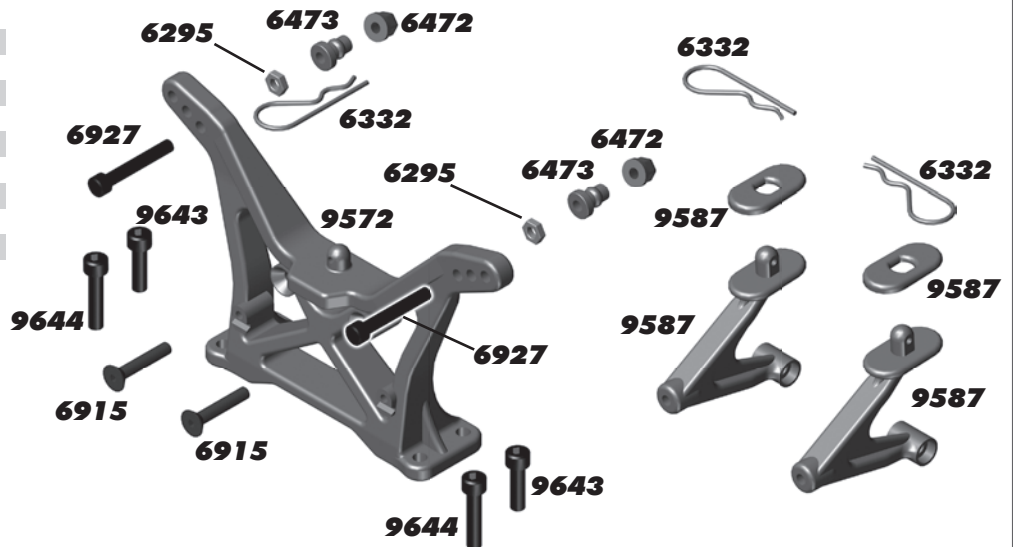

:: Wheels

9663	B4.2 Front Wheel/Tire Pre Mounts (white)	2
9664	B4.2 Rear Wheel/Tire Pre Mounts (white)	2
9690	Buggy Front Wheel, hex, white	2
9691	Buggy Front Wheel, hex, yellow	2
9695	Buggy Rear Wheel Hex, white	2
9696	Buggy Rear Wheel Hex, yellow	2

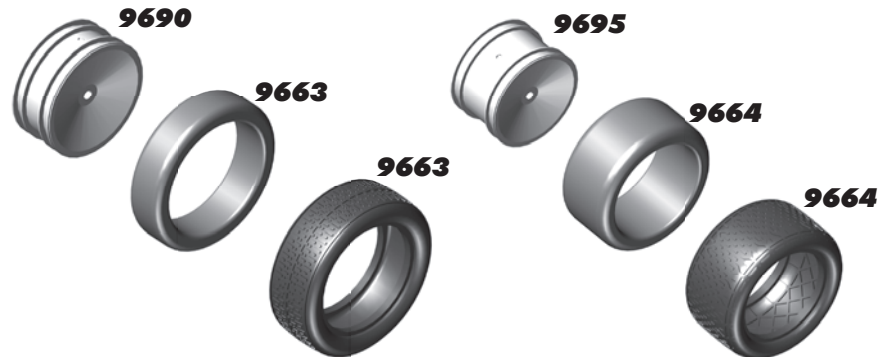

:: Steering

2221	4-40 x 7/16" BHCS	6
3856	Steering Bushings, Set	1
6272	Foam Ball end Dust Covers	28
6276	Ballstud .20" Silver (short)	6
6925	4-40 x 1/2" SHCS	6
6929	4-40 X 3/8" SHCS, w/hole	4
9566	B4 / T4 Top Plate	1
9610	Servo Saver / Steering Hardware	1
9640	B4 / T4 Steering Bolt, left & right	1
9657	B4 / T4 HD Servo Saver Spring	1
9659	B4 / T4 Steering Set. Includes Rack, Bellcrank, Servo Saver, Steering Brace	1

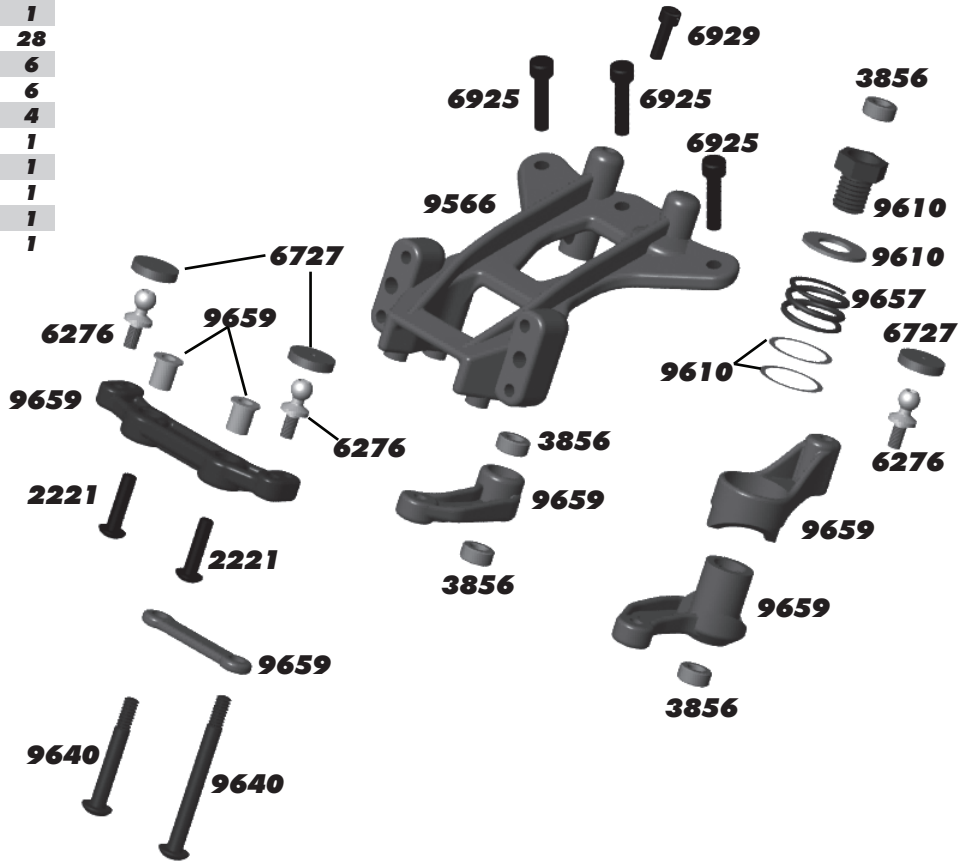

:: Transmission

3977	Ball Bearing, 3/16" x 3/8"	2
6913	4-40 x 1 1/4" SHCS	6
6919	4-40 x 5/16" BHCS	6
6922	4-40 x 1/2" FHCS	6
6924	4-40 x 3/8" SHCS	6
6925	4-40 x 1/2" SHCS	6
6928	4-40 x 1" SHCS	6
6936	#4 Washer, Aluminum	10
9360	Idler Gear, molded	1
9361	Idler Gear Shaft	1
9600	B4/T4 Motor Plate	1
9601	B4/T4 Top Shaft	1
9602	B4/T4 Top Shaft Spacer	1
9630	Ball End Washer	10
9819	Motor Guard	1
9826	SC10 Transmission Case (left & right)	1
9832	Ball Bearing, 10 x 16mm	2
31531	3 x 6mm BHCS	6

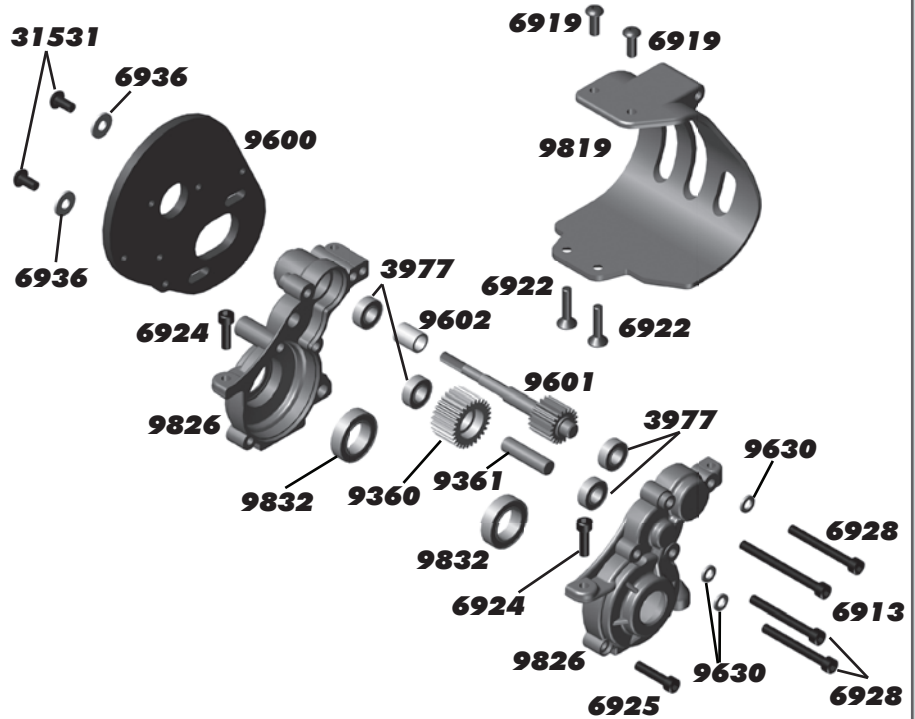

:: Chassis

3862	5-40 x 1/8" Set Screw	6
4334	2-56 x 5/16" BHCS	8
6272	Foam Ballend Dust Cover	28
6277	Ballstud .30" Silver (long)	4
6338	Antenna Tube (black)	1
6915	4-40 x 5/8" FHCS	6
9269	5-40 x 1/2" FHCS	6
9560	B4 Chassis, Composite	1
9562	Front Bumper	1
9563	B4 / T4 / GT2 Front Bulkhead	1
9564	RR / FR Hinge Brace	1
9621	Inner Hinge Pin Set	1
9630	.030 Ballstud Washer	10
9643	5-40 x 7/16" SHCS	6
9645	2-56 x 1/8" BHCS	8
9818	Rear Arm Mount / Chassis Plate	1
9877	Receiver Box	1
9878	Receiver Box Seals	1

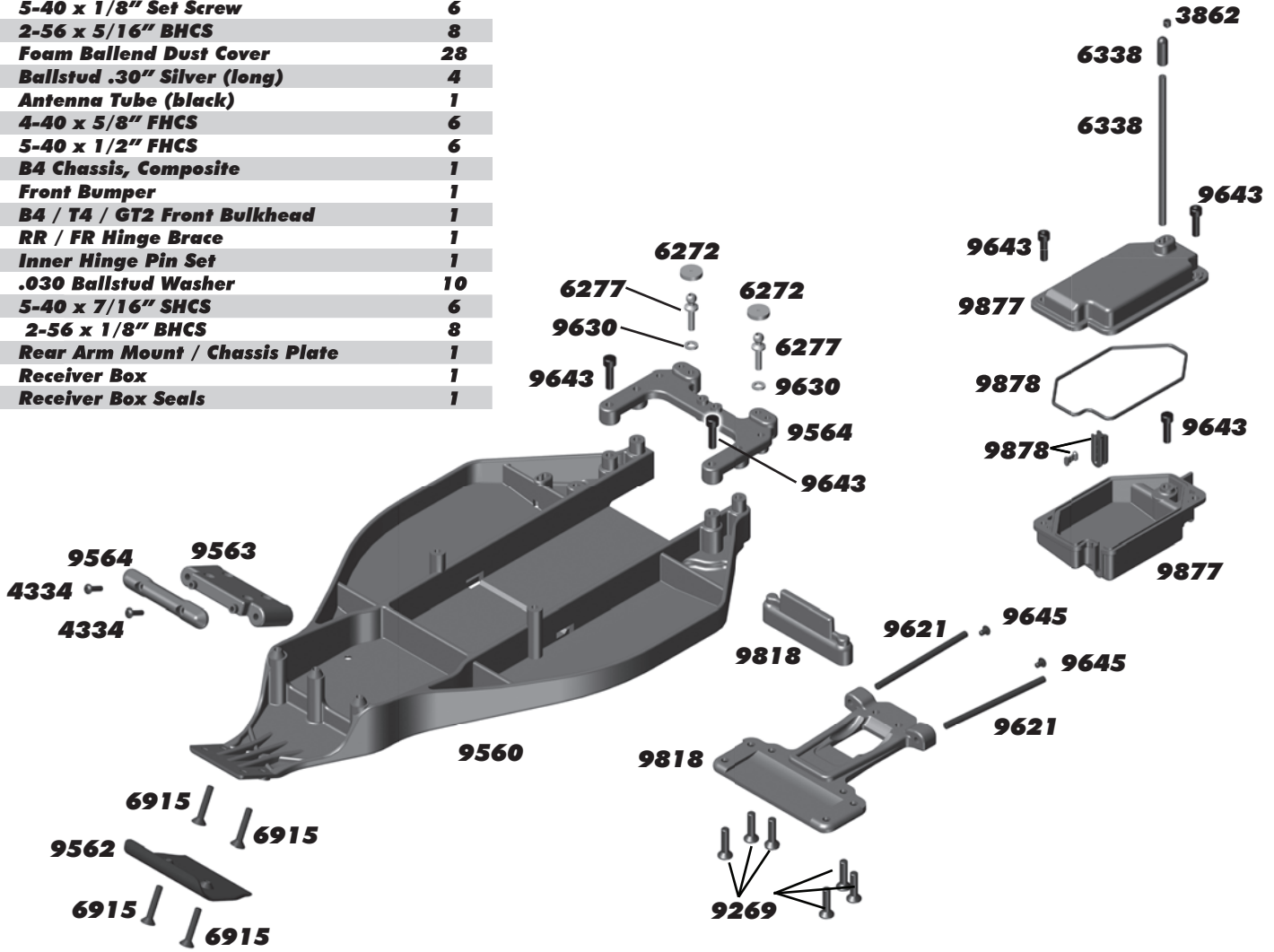

:: Lubes & Adhesives / Misc.

1105	FT Green Slime Shock Lube	1
1596	FT Locking Adhesive	1
1597	FT Tire Adhesive, medium	1
6588	Black Grease - 4cc	1
6591	S.Diff Lube - 4cc	1
6636	Silicone Grease - 4cc	1
6727	Servo Tape	2



:: Body and Decals

9614	B4 Clear Body & Wing	1
9658	B4 Decal Sheet	1
9675	B4 Painted Body, Flames, Blue Background	1
9676	B4 Painted Body, Flames, Red Background	1
9682	B4.2 RTR Body and Wing, Red	1
9683	B4.2 RTR Body and Wing, Blue	1
9692	B4 Vortex Body + Wings Set, clear	1
9772	High Downforce Wing 6.5"	1
9790	B4.1 RTR Body, Blue, with spoiler	1
9791	B4.1 RTR Body, Green, with spoiler	1
9792	B4.1 Body Clear, with spoiler	1
9782	B4.2 Decal Sheet	1

:: XP Electronics

29107	S1903 Metal Gear Set	1
29125	S1903MG Servo	1
29126	S2008MG Servo	1
29127	XP DS2008/S2008 Metal Gear Set	1
29133	XP DS1903 Servo	1
29134	XP DS1903MG Servo	1
29135	XP DS2008MG Servo	1
29138	XP SC500 Brushless ESC	1
29139	XP SC900-BL Brushless ESC	1
29142	XP ESC Fan Option	1
29143	XP SC700-BL Brushless ESC	1
29144	XP SC1200 Brushless ESC	1
29145	XP SC1300 Brushless ESC	1
29166	XP DS1313 Digital Servo	1
29167	XP DS1015 Digital Servo	1
29168	XP DS1510MG Digital Servo	1
29209	Gear Set, DS1313	1
29210	Gear Set, DS1015	1
29211	Servo Case, DS1313 / DS1015	1
29212	Accessory Pack, DS1313 / DS1015	1
29214	TRS 403-SSi Receiver	1
29215	XP2G 2.4GHz Radio System	1
29216	XP3G 2.4GHz Radio System	1
29251	XP DS1505MG Digital Servo	1

:: Factory Team and Option Parts

1406	FT Ti Turnbuckle, 2.00" (blue)	Pr.
1409	FT Ti Turnbuckle, 1" (sway bar) (blue)	Pr.
1585	FT B4 Aluminum Trailing Axle	Pr.
1654	FT Solid Axle Pins	4
1734	FT Blue Body Clip, 4 long, 6 short	10
1735	FT Blue Body Clip, long	4
1736	FT Blue Body Clip, short	6
1770	FT Milled Aluminum Motor Plate, (blue)	1
1777	Blue Aluminum Shock Ball Ends with Eyelets	4
1778	FT Milled Aluminum Motor Plate, (black)	1
1779	FT Servo Mounts, blue aluminum	Pr.
1780	FT Blue Alum. Threaded Shock Bushings (standard)	4
1781	FT Blue Alum. Threaded Shock Bushings (short)	4
1787	FT Battery Strap Thumb Screws	Pr.
3971	Steering Rack Bearings	4
6906	Ball Bearing, PTFE Sealed 3/16 x 3/8"	2
6937	FT 4-40 Aluminum Locknuts (blue)	6
6943	FT 8-32 Aluminum Locknuts (blue)	6
7381	CVD Rebuild Kit	1
7485	FT V2 Slipper Hubs	Pr.
7486	FT V2 Slipper Spring and Washer	1
7487	Arm Mount Set (2.5, 3, 3.5, 4 deg)	1
7922	Caster Block 30 deg, (left & right)	Pr.
7990	Aluminum Front Bulkhead	1
9561	B4 Chassis Carbon, short chassis	1
9565	Chassis Brace, Hinge Pin Brace, Carbon	1
9567	Top Plate, Carbon	1
9569	Front Shock Tower B4 Carbon	1
9573	Rear Shock Tower Carbon B4	1
9577	Steering Blocks, Inline (B4 req. #9623)	Pr.
9579	Front A-Arm B4 Carbon	Pr.
9583	Rear A-Arm B4 Carbon	Pr.
9586	Battery Strap Carbon, B4 (short chassis)	1
9592	Caster Block 20 deg, (left & right)	Pr.
9593	FT Caster Block, 30 deg, (left & right)	Pr.
9594	Battery Strap Woven Carbon, B4 (short chassis)	1
9597	CVD Axle Bones, B4	Pr.
9598	CVD Axles, B4 / T4	Pr.
9599	CVD Set, B4	1
9600B	FT Aluminum Motor Plate (blue)	1
9623	FT B4 Front Inline Axle (req. #9577)	Pr.
9635	B4 / T4 Sway Bar Kit. Includes color coded bars, soft (black), med (silver), hard (gold)	1
9636	B4 +8mm Conversion Kit	1
9655	B4 Full Carbon Set, (short chassis)	1
9665	FT B4 / T4 Aluminum Hinge Pin Brace	1
9672	FT CVA Bone, B4	Pr.
9673	B4 Shiny CVD Dogbone	Pr.
9677	FT CVA Set, B4	Pr.
9679	B4/T4 Aluminum Bellcrank Set	1
9739	Slipper Spring	1
9755	CVA Axle, Rear (B44, B4, T4, SC10)	Pr.
9789	FT Titanium Front Axles, SC10 / B4	Pr.
9795	Ti Nitride Ballstuds 4-40 x 0.20" Long	Pr.
9796	Ti Nitride Ballstuds 4-40 x 0.30" Long	Pr.
9797	Ti Nitride Ballstuds 4-40 x 0.40" Long	Pr.
9798	Ti Nitride Ballstuds 4-40 x 0.20" Short	Pr.
9799	Ti Nitride Ballstuds 4-40 x 0.30" Short	Pr.
9864	FT Aluminum Hub, 0 deg	Pr.
9865	FT Aluminum Hub, 0.5 deg	Pr.
9866	FT Aluminum Hub, 1 deg	Pr.
9867	FT Aluminum Hub, 1.5 deg	Pr.
9872	FT Aluminum Hub Tower Set	1
9890	12mm Alum. Clamping Wheel Hex, Buggy Rear	2
9891	12mm Alum. Clamping Wheel Hex, Buggy Front	2
9917	Aluminum Hub A, Carbon	Pr.
9918	Aluminum Hub Tower B, Graphite	Pr.
31237	CVA Pin Retaining Clip	Pr.
31286	FT Ballstud Washer, aluminum (1mm, 2mm)	4ea.
31327	VCS3 Shock Bottom Cap and O-Ring	2 ea.
91175	FT VTS Slipper Conversion	1
91176	VTS Slipper Housing	1
91177	VTS Slipper Pads	2

:: Factory Team and Option Parts cont.

91178	VTS Slipper Plate	1
91179	FT VTS Slipper Hub, outer	1
91299	12X23mm FT Shock Bodies (front)	2
91301	12X31mm FT Shock Bodies (rear)	2
91303	12MM Shock Cap	2
91304	12MM Threaded Collar and O-Ring	2
91305	21X3mm TiN Shock Shaft (front)	1
91306	27.5X3mm TiN Shock Shaft (rear)	1
91308	12MM Shock Pistons, (1.5, 1.6, 1.7)	4 ea.
91309	12MM Shock Rebuild Kit	1
91310	12MM Shock Spring Cups (+0mm, +5mm, +9mm)	4 ea.
91314	12MM Shock (B4/B44 Front)	2
91316	12MM Shock (B4/B44 Rear)	2
91325	12MM Front SPRING BRN 2.85	Pr.
91326	12MM Front SPRING BLK 3.00	Pr.
91327	12MM Front SPRING GRN 3.15	Pr.
91328	12MM Front SPRING WHT 3.30	Pr.
91329	12MM Front SPRING GRY 3.45	Pr.
91330	12MM Front SPRING BLU 3.60	Pr.
91331	12MM Front SPRING YLW 3.75	Pr.
91332	12MM Front SPRING RED 3.90	Pr.
91333	12MM Front SPRING ORN 4.05	Pr.
91334	12MM Front SPRING PRL 4.20	Pr.
91335	12MM Rear SPRING BLK 1.90	Pr.
91336	12MM Rear SPRING GRN 2.00	Pr.
91337	12MM Rear SPRING WHT 2.10	Pr.
91338	12MM Rear SPRING GRY 2.20	Pr.
91339	12MM Rear SPRING BLU 2.30	Pr.
91340	12MM Rear SPRING YLW 2.40	Pr.
91341	12mm Big Bore Front Soft Spring Kit	1
91342	12mm Big Bore Front Medium Spring Kit	1
91343	12mm Big Bore Front Hard Spring Kit	1
91344	12mm Big Bore Rear Soft Spring Kit	1
91345	12mm Big Bore Rear Medium Spring Kit	1

:: Reedy Motors and ESC's

231	Sonic 540 Mach 2 21.5 Competition Brushless Motor	1
232	Sonic 540 Mach 2 17.5 Competition Brushless Motor	1
233	Sonic 540 Mach 2 13.5 Competition Brushless Motor	1
234	Sonic 540 Mach 2 10.5 Competition Brushless Motor	1
235	Sonic 540 Mach 2 9.5 Competition Brushless Motor	1
236	Sonic 540 Mach 2 8.5 Competition Brushless Motor	1
237	Sonic 540 Mach 2 8.0 Competition Brushless Motor	1
238	Sonic 540 Mach 2 7.5 Competition Brushless Motor	1
239	Sonic 540 Mach 2 7.0 Competition Brushless Motor	1
240	Sonic 540 Mach 2 6.5 Competition Brushless Motor	1
241	Sonic 540 Mach 2 6.0 Competition Brushless Motor	1
242	Sonic 540 Mach 2 5.5 Competition Brushless Motor	1
243	Sonic 540 Mach 2 5.0 Competition Brushless Motor	1
244	Sonic 540 Mach 2 4.5 Competition Brushless Motor	1
245	Sonic 540 Mach 2 4.0 Competition Brushless Motor	1
246	Sonic 540 Mach 2 3.5 Competition Brushless Motor	1
908	Replacement Rotor 540-SL	1
920	540-SL Brushless Motor 3300kV	1
921	540-SL Brushless Motor 3900kV	1
922	540-SL Brushless Motor 4900kV	1
923	540-SL Brushless Motor 6100kV	1
954	Sonic 540 Stock Rotor 12.3 x 24.2 (7.25)	1
955	Sonic 540 Stock Rotor 12.3 x 25.0 (7.25)	1
956	Sonic 540 Stock Rotor 12.5 x 25.0 (7.25)	1
957	Sonic 540 Modified Rotor 12.2 x 25.0 (5.0)	1
958	Sonic 540 Modified Rotor 12.5 x 25.0 (5.0)	1
965	Reedy 540-SL 3300kV/XP SC700-BL ESC Combo	1
966	Reedy 540-SL 3900kV/XP SC700-BL ESC Combo	1
967	Reedy 540-SL 4900kV/XP SC700-BL ESC Combo	1
983	Reedy 540-SL 3300kV/XP SC1200-BL ESC Combo	1
984	Reedy 540-SL 3900kV/XP SC1200-BL ESC Combo	1
985	Reedy 540-SL 4900kV/XP SC1200-BL ESC Combo	1
986	Reedy 540-SL 6100kV/XP SC1200-BL ESC Combo	1
987	Sonic 540 Modified Rotor 13.0 x 25.0 (5.0)	1

:: Reedy Batteries

302	AA Alkaline 1.5V (4)	1
303	AA 2700mAh NiMH 1.2V Rechargeable (4)	1
309	LiPo 65C 7000mAh 7.4V	1
602	LiPo 65C 4100mAh 7.4V Shorty	1
628	LiPo 60C 5500mAh 7.4V	1
681	Wolfpack 2400mAh 7.2V w/DEANS® connector	1
682	Wolfpack 3000mAh 7.2V w/DEANS® connector	1
683	Wolfpack 3600mAh 7.2V w/DEANS® connector	1
684	Wolfpack 4200mAh 7.2V w/DEANS® connector	1
730	Wolfpack LiPo 3000mAh 7.4V 25C w/DEANS®	1
731	Wolfpack LiPo 3300mAh 7.4V 35C w/DEANS®	1
732	Wolfpack LiPo 3400mAh 7.4V 35C w/DEANS®	1
734	Wolfpack LiPo 6500mAh 7.4V 25C w/DEANS®	1
736	Wolfpack LiPo 5000mAh 7.4V 25C	1
738	Wolfpack LiPo 3800mAh 7.4V 25C Shorty	1

:: Reedy Accessories

247	Sonic 540 Mach 2 Sensor w/bearing	1
248	Sonic 540 Mach 2 Steel Bearing Set	1
249	Sonic 540 Mach 2 Ceramic Bearing Set	1
250	Sonic 540 Mach 2 Insulator Set	1
604	526-S AC/DC 2S-6S LiPo/LiFe Charger	1
607	Charge Harness 2S Standard Pack 4mm	1
609	TAM to DEANS® charge adapter	1
610	447-S AC/DC NiMH Peak Charger	1
654	4.0mm plugs (2M, 2F)	1
655	4.0mm plugs (2M, 10F)	1
656	4.0mm plugs (10F)	1
657	4.0mm plugs (100F)	1
658	4.0mm plugs (10M)	1
659	4.0mm plugs (30M)	1
660	3.5mm plugs (3M, 3F)	1
661	3.5mm plugs (10F)	1
662	3.5mm plugs (100F)	1
663	3.5mm plugs (10M)	1
664	3.5mm plugs (30M)	1
716	Reedy 09 Decal Set	1
974	540-SL/550-SL Steel Bearing Set	1
975	540-SL/550-SL Ceramic Bearing Set	1
978	Flat Sensor Wire 70mm	1
979	Flat Sensor Wire 110mm	1
980	Flat Sensor Wire 150mm	1
981	Flat Sensor Wire 200mm	1
982	Flat Sensor Wire 270mm	1
992	Sonic 540 Rotor Spacers	1

:: LRP Speed Controls

LRP80230	Spin Super Brushless	1
LRP80250	Spin Pro Brushless	1
LRP80960	Flow Competition	1
LRP80970	Flow Works Team	1

:: LRP Chargers, Power Supply, Balancer

LRP41281	Quadra Pro 2 Charger	1
LRP41555	Pulsar Touch Competition Charger	1
LRP42103	LiPo Balance Board XH	1
LRP42104	LiPo Balance Board FP/TP	1
LRP42105	LiPo Balance Board PQ	1
LRP42305	Pulsar Touch Temperature Sensor	1
LRP42306	Pulsar Touch Sensor Wire Splitter	1
LRP43200	LRP Competition 20A Power Supply	1
LRP45050	LRP 2in1 LiPo Guard + BEC	1
LRP45200	LiPo Parallel Balancer	1
LRP65800	High Power Solder Station	1
LRP65802	Soldering Tip 5mm	1
LRP65803	Soldering Tip 1.2mm	1
LRP65804	Soldering Handle	1
LRP81801	LRP Speedo Updater Spec 2	1

:: LRP Brushless Motors / Combos

LRP50430	Vector K4 6.5 Turn	1
LRP50440	Vector K4 8.5 Turn	1
LRP50450	Vector K4 10.5 Turn	1
LRP50460	Vector K4 13.5 Turn	1
LRP50480	Vector K4 17.5 Turn	1
LRP50643	Vector X-20 10.5 Turn	1
LRP50644	Vector X-20 9.5 Turn	1
LRP50654	Vector X-20 8.5 Turn	1
LRP50664	Vector X-20 7.5 Turn	1
LRP50674	Vector X-20 6.5 Turn	1
LRP50684	Vector X-20 5.5 Turn	1
LRP50689	Vector X-20 5.0 Turn	1
LRP50694	Vector X-20 4.5 Turn	1
LRP50704	Vector X-20 4.0 Turn	1
LRP80741	Spin Super / K4 17.5 Turn	1
LRP80742	Spin Super / K4 13.5 Turn	1
LRP80743	Spin Super / K4 10.5 Turn	1

:: LRP Misc.

LRP62415	LRP Logo Sticker Sheet	1
LRP80135	BEC Stabilizing Capacitor	1
LRP82512	SXX Low Profile Fan	1
LRP82515	30mm Motor Fan/Clamp, Gunmetal	1
LRP82520	Radical Cooling Set, Blue	1
LRP82530	SXX Power Cap 3.7-4.8V	1
LRP82531	SXX Power Cap 6.0-7.4V	1
LRP819307	70mm High Flex Sensor Wire	1
LRP819310	100mm High Flex Sensor Wire	1
LRP819315	150mm High Flex Sensor Wire	1
LRP819320	200mm High Flex Sensor Wire	1

:: Qualifier Series Vehicles

7052	Pro Lite 4x4 RTR, 1/10 Scale (ready-to-run)	1
20510	RIVAL Electric Monster Truck RTR, 1/8 Scale (ready-to-run)	1
30112	APEX Touring V-Type, 1/10 Scale (ready-to-run)	1

:: 1/18 Kits and RTR's

20103	RC18B2 - RC18T2 Team Kit	1
20121	SC18 RTR Brushless (ready-to-run)	1

:: 1/12, 1/10 Kits and RTR's

2042	Nitro TC3 RTR Plus (ready-to-run)	1
4020	FT 12R5.2 Kit	1
7025	RC10T4.2 FT Kit	1
7029	SC10 Associated/RC10.com Truck RTR (ready-to-run)	1
7030	SC10 KMC Wheels Race Truck RTR (ready-to-run)	1
7038	SC10.2 FT Kit	1
7039	RC10T4.2 RS RTR 2.4GHz Brushless (ready-to-run)	1
7046	SC10 RS RTR, Lucas Oil (ready-to-run)	1
7048	SC10 RS RTR, Pro Comp (ready-to-run)	1
7049	SC10 RS RTR, Rockstar/Makita (ready-to-run)	1
7050	SC10 RS RTR, Hart and Huntington (ready-to-run)	1
7093	SC10GT RTR (ready-to-run)	1
8020	FT RC10R5 Kit	1
8022	FT RC10R5.1 Kit	1
9040	FT RC10B4.1 Worlds Kit	1
9041	FT RC10B4.2 Kit	1
9042	RC10B4.2 RS RTR 2.4GHz Brushless (ready-to-run)	1
9050	SC10B RS RTR (ready-to-run)	1
9062	FT B44.2 4WD Buggy Kit	1
30101	TC4 Club Racer 4WD Touring Car Race Roller	1
30108	FT TC6.1 WC 4WD Touring Car Kit	1
90005	SC10 4x4 Lucas Oil RTR (ready-to-run)	1
90006	SC10 4x4 Pro Comp RTR (ready-to-run)	1
90007	SC10 4x4 Rockstar/Makita RTR (ready-to-run)	1
90010	SC10 4x4 FT Kit	1

:: 1/8 Kits and RTR's

20501	MGT 4.60 SE RTR (ready-to-run)	1
20502	MGT 8.0 Nitro RTR (ready-to-run)	1
20503	Limited Edition MGT 4.60 Nitro RTR, w/flag body (ready-to-run)	1
20504	Limited Edition MGT 8.0 Nitro RTR, w/flag body (ready-to-run)	1
80905	RC8RS "Race Spec" Nitro Buggy RTR (ready-to-run)	1
80906	RC8.2 Nitro Buggy FT Kit	1
80907	RC8.2e Electric Buggy FT Kit	1
80908	RC8.2e Electric Buggy RTR (ready-to-run)	1
80912	RC8T Championship Edition	1
80933	SC8.2e Short Course Race Truck, Rockstar/Makita Electric RTR (ready-to-run)	1
80934	SC8.2e Short Course Race Truck, Slick Mist Electric RTR (ready-to-run)	1

:: Tools

1111	FT Turnbuckle Wrench	1
1113	12mm Big Bore Shock Tool	1
1449	FT Off Road Ride Height Gauge	1
1541	FT Hex Driver Set, (7 pcs)	1
1542	FT .050" Silver Hex Driver	1
1543	FT 1/16" Black Hex Driver	1
1544	FT 1.5mm Purple Hex Driver	1
1545	FT 5/64" Blue Hex Driver	1
1546	FT 3/32" Gold Hex Driver	1
1547	FT 2.5mm Green Hex Driver	1
1548	FT 3mm Red Hex Driver	1
1551	FT Screwdriver Set	1
1553	FT Phillips Silver Screwdriver	1
1554	FT Silver Spring Hook Tool	1
1561	FT Nut Driver Set, (6 pcs)	1
1562	FT 3/16" Black Nut Driver	1
1563	FT 1/4" Red Nut Driver	1
1564	FT 5.5mm Red Nut Driver	1
1565	FT 11/32" Green Nut Driver	1
1567	FT 8mm Gold Nut Driver	1
1589	FT 5/64" Blue Ball Hex Driver	1
1590	FT 3/32" Gold Ball Hex Driver	1
1592	FT Ball Hex Driver Set, (3 pcs)	1
1655	FT 8-Piece 1/4" Hex Drive Set	1
1656	FT 1/4" Hex Drive Handle, without tips	1
1657	FT 1/4" Hex Drive .050" Tip	1
1658	FT 1/4" Hex Drive 1/16" Tip	1
1659	FT 1/4" Hex Drive 5/64" - 2.0mm Tip	1
1660	FT 1/4" Hex Drive 3/32" Tip	1
1661	FT 1/4" Hex Drive 1.5mm Tip	1
1662	FT 1/4" Hex Drive 2.5mm Tip	1
1663	FT 1/4" Hex Drive 3/16" Nut Driver Tip	1
1664	FT 1/4" Hex Drive 1/4" Nut Driver Tip	1
1665	FT 1/4" Hex Drive 11/32" Nut Driver Tip	1
1666	FT 1/4" Hex Drive 5.5mm Nut Driver Tip	1
1667	FT 1/4" Hex Drive 7.0mm Nut Driver Tip	1
1668	FT 1/4" Hex Drive 8.0mm Nut Driver Tip	1
1669	FT 1/4" Hex Drive 5/64" - 2.0mm Ball End Tip	1
1670	FT 1/4" Hex Drive 3/32" Ball End Tip	1
1671	FT 1/4" Hex Drive Standard Screwdriver Tip	1
1672	FT 1/4" Hex Drive Phillips Screwdriver Tip	1
1673	FT 1/4" Hex Drive 2.5mm Ball End Tip	1
1674	FT 1/4" 5 Piece Power Tool Tips Set (5/64"-2.0mm, 1.5mm, 2.5mm, 5/64"- 2.0mm ball, 2.5mm ball)	1
1719	FT Camber + Track Width Tool	1
1737	FT Body Scissors	1
3718	12 Inch Nylon Wire Ties	12
3719	6 Inch Nylon Wire Ties	12
3720	8 Inch Nylon Wire Ties	12
3987	FT Droop Gauge	1
6429	Shock Building Tool	1
6956	Molded Tools, Set	1
7494	V2 Stamped Multi-tool	1
7709	4 Inch Nylon Wire Ties	12

:: RePlay Cameras

RP001	Replay XD1080 Complete Camera System	1
RP002	Replay XD720 Complete Camera System	1
RP021	Replay XD1080 Lens Bezel Kit	1
RP022	Replay XD1080 Clear Lens Cover	1
RP023	Replay XD1080 Lens Bezel & Rear Cap O-Ring	1
RP029	Replay XD1080 HDMI to Mini-HDMI	1
RP030	Replay XD1080 Mini 8-pin USB Charge Data Cable	1
RP032	USB DC Car Charger 1A Stubby	1
RP033	USB DC Car Charger 500mAh	1
RP034	Micro SDHC USB Reader	1
RP036	3M VHB 4991 Mount Adhesive for SnapTray	1
RP037	3M VHB 5962 Mount Adhesive for Pro Flat Mount	1
RP038	3M VHB 5962 Mount Adhesive for SnapTray	1
RP041	Replay XD Suction Cup Arm Mini Clamp	1
RP042	Replay XD Suction Cup Short Arm Base	1
RP043	Replay XD Skateboard Mount	1
RP044	Replay XD VHB SnapTray, Convex	1
RP045	Replay XD VHB SnapTray, Flat	1
RP046	Au Plug for Universal DC Wall Charger	1
RP047	Eu Plug for Universal DC Wall Charger	1
RP048	Uk Plug for Universal DC Wall Charger	1
RP049	Universal USB DC Wall Charger 1A	1
RP054	Replay ReView Field Monitor	1

:: Apparel

SP35**	Reedy 09' White T-Shirt (L, XL, 2XL)	1
SP36**	Reedy 09' Black T-Shirt (M, L, XL, 2XL, 3XL)	1
SP37**	Reedy 2012 T-shirt - Black (S, M, L, XL, 2XL, 3XL)	1
SP38	Reedy Trucker Hat	1
SP39	Reedy Patch	1
SP66**	Stencil Blue T-Shirt (S, M, L, XL, 2-6XL)	1
SP67**	AE Stencil Gray Sweatshirt (S, M, L, XL, 2XL, 3XL)	1
SP68**	AE Stencil Blue T-Shirt (M, L, XL)	1
SP69**	AE 26 Time World Championship T-Shirt, Black (S, M, L, XL, 2XL, 3XL)	1
SP70**	Associated Windbreaker (S, M, L, XL, 3XL)	1
SP71**	Associated Winter Jacket (S, M, L, XL, 2XL)	1
SP73**	AE Long Sleeve T-Shirt (S, M, L, XL, 2XL)	1
SP74**	AE White T-Shirt (S, M, L, XL, 2XL, 3XL, 4XL)	1
SP75**	AE Blue T-Shirt (S, M, L, XL, 2-6XL)	1
SP76**	AE Black T-Shirt (S, M, L, XL, 2XL, 3XL, 4XL)	1
SP77**	AE 2012 T-Shirt, Blue (S, M, L, XL, 2XL, 3XL)	1
SP78**	AE 2012 T-Shirt, White (S, M, L, XL, 2XL, 3XL)	1
SP79**	AE 2012 T-Shirt, Black (S, M, L, XL, 2XL, 3XL)	1
SP84**	Reedy 3D T-Shirt, Black (S, M, L, XL, 2XL, 3XL)	1
SP85**	Reedy Zip Hoodie, Black (S, M, L, XL, 2XL, 3XL)	1
SP86**	Reedy Girl's 3D T-Shirt, Black (S, M, L, XL)	1
SP87**	AE 2013 Zip Hoodie (S, M, L, XL, 2XL, 3XL)	1
SP102	Outer & Inner Boxes, for #SP-416	1
SP103	Inner Boxes only, for #SP416	1
SP411S	AE Hat 11' Flat Bill Black S/M	1
SP411L	AE Hat 11' Flat Bill Black L/XL	1
SP413S	26 Time World Championship Hat S/M	1
SP413L	26 Time World Championship Hat L/XL	1
SP416	Associated Car Carrier Bag, Medium	1
SP417	1/10 FT Motor Bag	1
SP418	Factory Team 1/10 Car Carrier Bag	1
SP420**	AE Pit Gloves (M, L, XL)	Pr.
SP421S	AE 2012 Hat, Black, Flat Bill, S/M	1
SP421L	AE 2012 Hat, Black, Flat Bill, L/XL	1
SP422S	AE 2012 Hat, Black, Curved Bill, S/M	1
SP422L	AE 2012 Hat, Black, Curved Bill, L/XL	1
SP423S	AE 2012 Hat, White, Flat Bill, S/M	1
SP423L	AE 2012 Hat, White, Flat Bill, L/XL	1
SP424S	AE 2012 Hat, White, Curved Bill, S/M	1
SP424L	AE 2012 Hat, White, Curved Bill, L/XL	1
715	Reedy 2009 Track Banner	1
110684	Team Associated Track Banner	1

Front Suspension

Camber: _____ *-1*

Toe: _____ *0*

Washers: _____ *2mm*

Ride Height: _____ *24mm*

Steering Rack:

Front Back

Washers: _____ *2mm*

Caster Block Spacing:
 Forward
 Back

Caster:
 20°
 25°
 30°

Rear Suspension

Camber: _____ *-1*

Inner Toe: _____ *3°*

Anti-Squat: _____ *2°*

Washers: _____ *1mm*

Chassis Brace Ground Flat:

Ride Height: _____ *24mm*

Wheelbase:
 Long
 Medium
 Short

Rear Hub Carriers:

- 0°
- 0.5°
- 1°
- 1.5°

Aluminum Hub Tower:

- A
- B
- C

Anti Roll Bar:

- None
- Black (soft)
- Silver (med)
- Gold (hard)

Front Shocks

Spring: *Brown* **Piston:** *#1*

Shock Oil: *30wt* **Limiter:** *0*

Rear Shocks

Spring: *Black* **Piston:** *#1*

Shock Oil: *30wt* **Limiter:** *2*

Electronics / Weight

Motor & Wind: _____

Pinion: *21T* **Spur Gear:** *81T*

Batteries: _____

Battery Placement: _____

Ballast Weight: _____

Chassis Weight: _____

Radio: _____

Throttle / Brake e.p.a: _____

Throttle / Brake expo: _____

Servo: _____ **Steering Expo:** _____

ESC: _____

ESC Settings: _____

Front Tires

Tire: *Stock*

Compound: *Stock*

Insert: *Stock* **Wheel:** *Stock*

Rear Tires

Tire: _____

Compound: _____

Insert: _____ **Wheel:** *Stock*

Drivetrain

Slipper: *Stock*

2 Pads **3 Pads** **4 Pads**

Notes: _____

Differentials

Ball:

Gear:

Notes: _____

Other

Body Type: _____ *Stock*

Wing Type: _____ *Stock* **Wing Angle:** _____

Race and Vehicle Comments

Qualify: _____ **Main:** _____ **Finish:** _____ **TQ:** _____















Comments: _____

Track Info

Surface:	Traction:	Conditions:	Moisture:
Dirt <input type="checkbox"/>	Low <input type="checkbox"/>	Grooved <input type="checkbox"/>	Wet <input type="checkbox"/>
Carpet <input type="checkbox"/>	Med <input type="checkbox"/>	Dusty <input type="checkbox"/>	Damp <input type="checkbox"/>
Astro <input type="checkbox"/>	High <input type="checkbox"/>	Smooth <input type="checkbox"/>	Dry <input type="checkbox"/>
Multi <input type="checkbox"/>		Bumpy <input type="checkbox"/>	
		Hard Pack <input type="checkbox"/>	
		Loamy <input type="checkbox"/>	

:: Hardware - 1:1 Scale View





Cap Head (shcs)

-  **2-56x 3/16 (9898)**
-  **4-40x1/4 (6285)**
-  **4-40x5/16" (6932)**
(4145, aluminum)
-  **4-40x3/8 (6924)**
w/hole (6929)
-  **4-40x1/2 (6925)**
-  **4-40x5/8 (6926)**
-  **4-40x3/4 (6927)**
-  **4-40x7/8 (7738)**
-  **4-40x1 (6928)**
-  **4-40x1 1/4 (6913)**
-  **4-40x1 3/4 (9833)**
-  **5-40x7/16 (9643)**
-  **5-40x9/16 (9644)**
-  **5-40x7/3/4 (9835)**







Ballstuds

-  **Black .20 Short (3981)**
-  **Black .30 Short (3983)**
-  **Silver .20 Short (6276)**
-  **Silver .30 Long (6277)**
-  **Silver .40 (6278)**





Flat Head (fhcs)

-  **4-40x3/8 (6292)**
-  **4-40x1/2 (6922)**
-  **4-40x5/8 (6915)**
-  **5-40x1/2 (9269)**









Shims and Washers

-  **.030 Ballstud Washer (9630)**
-  **.030 Nylon Spacer (4187)**
-  **Servo Mount Washer (7337)**
-  **#4 Washer (6936)**
-  **3/16 Axle Shim - Silver (7368)**
-  **FT Ballstud Washer, Aluminum**
(1mm and 2mm, 4 each) (31286)





Ball Bearings

-  **Steering Rack Bearing**
(3971)
-  **3/16x3/8 (3977)**
-  **3/16x1/2 RS (7935)**
-  **10 x 16mm (9832)**

Button Head (bhcs)

-  **2-56x1/8 (9645)**
-  **2-56x5/16 (4334)**
-  **4-40x5/16 (6919)**
-  **4-40x3/8 (6917)**
-  **4-40x7/16 (2221)**
-  **4-40x3/4 (7413)**
-  **4-40x7/8 (91311)**
-  **3x8mm (31532)**

Nuts (lock/plain)

-  **4-40 Aluminum Locknut (4449)**
-  **4-40 Plastic Nut (6472)**
-  **5-40 Diff Locknut (6629)**
-  **8-32 LP Steel Locknut (6953)**
-  **8-32 Steel Locknut (6952)**

Clips

-  **E-clip 1/8 (6299)**

Diff Balls

-  **5/64 Diff Thrust Balls (6574)**
-  **3/32 Carbide Diff Balls (6581)**

Notes:

Front Suspension

Camber: _____

Toe: _____

Washers: _____

Ride Height: _____

Steering Rack:

Front Back

Caster Block Spacing:
 Forward
 Back

Washers: _____

Caster:
 20°
 25°
 30°

Rear Suspension

Camber: _____

Inner Toe: _____

Anti-Squat: _____

Washers: _____

Chassis Brace Ground Flat:

Ride Height: _____

Wheelbase:
 Long
 Medium
 Short

Rear Hub Carriers:

- 0°
- 0.5°
- 1°
- 1.5°

Aluminum Hub Tower:

- A
- B
- C

Anti Roll Bar:

- None
- Black (soft)
- Silver (med)
- Gold (hard)

Front Shocks

Spring: _____ **Piston:** _____

Shock Oil: _____ **Limiters:** _____

Rear Shocks

Spring: _____ **Piston:** _____

Shock Oil: _____ **Limiters:** _____

Electronics / Weight

Motor & Wind: _____

Pinion: _____ **Spur Gear:** _____

Batteries: _____

Battery Placement: _____

Ballast Weight: _____

Chassis Weight: _____

Radio: _____

Throttle / Brake e.p.a.: _____

Throttle / Brake expo: _____

Servo: _____ **Steering Expo:** _____

ESC: _____

ESC Settings: _____

Front Tires

Tire: _____

Compound: _____

Insert: _____ **Wheel:** _____

Rear Tires

Tire: _____

Compound: _____

Insert: _____ **Wheel:** _____

Drivetrain

Slipper: _____

2 Pads **3 Pads** **4 Pads**

Notes: _____

Differentials

Ball:

Gear:

Notes: _____

Other

Body Type: _____

Wing Type: _____ **Wing Angle:** _____

Race and Vehicle Comments

Qualify: _____ **Main:** _____ **Finish:** _____ **TQ:** _____

Comments: _____

Surface:	Traction:	Conditions:	Moisture:
Dirt <input type="checkbox"/>	Low <input type="checkbox"/>	Grooved <input type="checkbox"/>	Wet <input type="checkbox"/>
Carpets <input type="checkbox"/>	Med <input type="checkbox"/>	Dusty <input type="checkbox"/>	Damp <input type="checkbox"/>
Astro <input type="checkbox"/>	High <input type="checkbox"/>	Smooth <input type="checkbox"/>	Dry <input type="checkbox"/>
Multi <input type="checkbox"/>		Bumpy <input type="checkbox"/>	
		Hard Pack <input type="checkbox"/>	
		Loamy <input type="checkbox"/>	



**Associated Electrics, Inc.
26021 Commercentre Dr.
Lake Forest, CA 92630 USA**

<http://www.TeamAssociated.com>

<https://www.RC10.com>

https://twitter/Team_Associated

<https://bit.ly/AEonFacebook>

call: (949) 544-7500 - fax: (949) 544-7501

**Check out the following web sites for all of our kits,
current products, new releases, setup help, tips, and racing info!
www.TeamAssociated.com - www.RC10.com**