

### Front Suspension

Steering  
 Stop Gap: \_\_\_\_\_

Washers: \_\_\_\_\_  
 Bumpsteer  
 Washers: \_\_\_\_\_

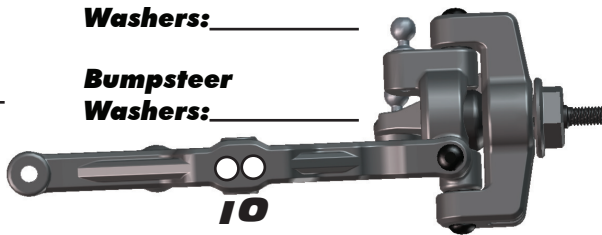

Anti Roll Bar:

1.5mm   
 2.0mm   
 2.2mm   
 None



Universal   
 CVA

Camber: \_\_\_\_\_

Toe: \_\_\_\_\_

Ride Height: \_\_\_\_\_

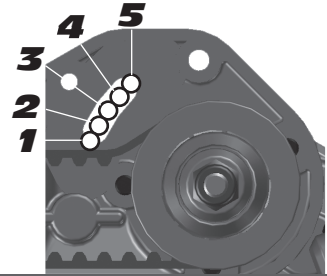

Washers: \_\_\_\_\_  
 Front Pulley:  
 20T (standard)   
 19T (overdrive)   
 Clicker:   
 Full Time 4X4:

### Rear Suspension

Wheelbase:  
 Long   
 Medium   
 Short



Anti Roll Bar:

1.5mm   
 2.0mm   
 2.2mm   
 None



Universal   
 CVA

Camber: \_\_\_\_\_

Ride Height: \_\_\_\_\_

Toe Block: 3+2   
 3+3

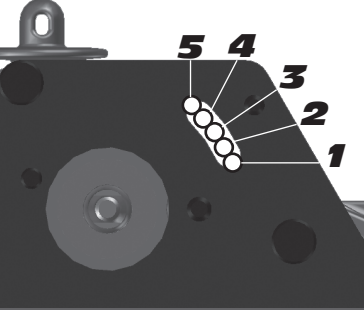

Washers: \_\_\_\_\_  
 Rear Pulley:  
 20T (standard)   
 19T (underdrive)   
 Slipper Pad Notes: \_\_\_\_\_

### Front Shocks

Spring: \_\_\_\_\_ Piston: \_\_\_\_\_  
 Shock Fluid: \_\_\_\_\_ Limiter: \_\_\_\_\_  
 Rebound: \_\_\_\_\_ Bladder  Emulsion

### Rear Shocks

Spring: \_\_\_\_\_ Piston: \_\_\_\_\_  
 Shock Fluid: \_\_\_\_\_ Limiter: \_\_\_\_\_  
 Rebound: \_\_\_\_\_ Bladder  Emulsion

### Electronics

Motor & Wind: \_\_\_\_\_  
 Pinion: \_\_\_\_\_  
 Spur Gear: \_\_\_\_\_  
 Batteries: \_\_\_\_\_  
 Battery Placement: Front  Middle  Back   
 Other

Radio: \_\_\_\_\_  
 Throttle / Brake e.p.a: \_\_\_\_\_  
 Throttle / Brake expo: \_\_\_\_\_  
 Servo: \_\_\_\_\_ Steering Expo: \_\_\_\_\_  
 ESC: \_\_\_\_\_  
 ESC Profile: \_\_\_\_\_

### Differentials

Front Diff Fluid: \_\_\_\_\_  
 Rear Diff Fluid: \_\_\_\_\_

### Other

Body Type: \_\_\_\_\_  
 Body Notes: \_\_\_\_\_

### Front Tires

Tire: \_\_\_\_\_ Compound: \_\_\_\_\_  
 Insert: \_\_\_\_\_ Wheel: \_\_\_\_\_  
 Notes: \_\_\_\_\_

### Rear Tires

Tire: \_\_\_\_\_ Compound: \_\_\_\_\_  
 Insert: \_\_\_\_\_ Wheel: \_\_\_\_\_  
 Notes: \_\_\_\_\_

### Race and Vehicle Comments

Qualify: \_\_\_\_\_ Main: \_\_\_\_\_ Finish: \_\_\_\_\_ TQ: \_\_\_\_\_  
 Comments: \_\_\_\_\_

### Track Info

Smooth:  Bumpy:  Blue Groove:   
 Traction: High:  Medium:  Low:   
 Soft Dirt:  Grass:  Clay:  Wet:   
 Dusty:  Other: \_\_\_\_\_