

Front	Alignment	Rear
6.5	Ride Height	6.5
-1.5	Camber	-1.5
4DEG	Caster	N/A
N/A	Rear Hub Toe	0
0	Toe (Total)	3.5
1MM	Hex Spacing	0
2-1	Wheelbase	2-1
2B	Steering Link	N/A
3MM	Bumpsteer	N/A

Notes:

Suspension Geometry		
1B	Shock Position	2b
1	Camber Link Position	1a
0	Outer Ball & Shims	2mm
3A	FWD Arm Mount	3a
0	FWD Mount Shims	0
3A	RWD Arm Mount	3a
0	RWD Mount Shims	2.5mm
6	Droop	6
SILVER	Anti-Roll Bar	silver

Notes:

Shocks		
MUCH MORE 50	Oil	MUCH MORE 50
2	Piston	2
50%	Rebound	50%
HPI SILVER	Spring	HPI SILVER

Notes:

Differentials		
SPOOL	Type	DIFF
N/A	Setting	
B	Cam Holder	B
1	Belt Tension Number	16

Notes:

Tires		
SWEEP 32	Tire	SWEEP 32
	Tire Diameter	
	Insert & Wheel	
TWEAK	Additive & Amount	TWEAK

Notes: WARMED AT 50DEG FOR 30MINS

Chassis		
Chassis: ITF		
Top Plate: ITF		
Notes:		

Transmitter	
Turning Circle:	
Steering Expo:	-10
Brake E.P.:	0
Throttle Expo:	0
Speed Control	
S.C. Type:	TEAM WAVE
S.C. Settings:	

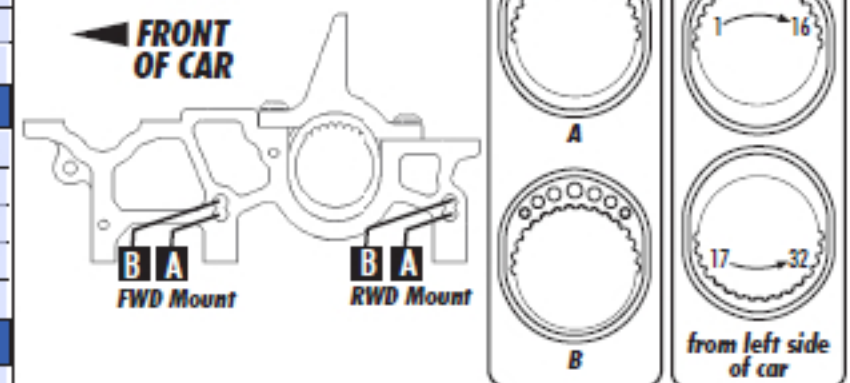
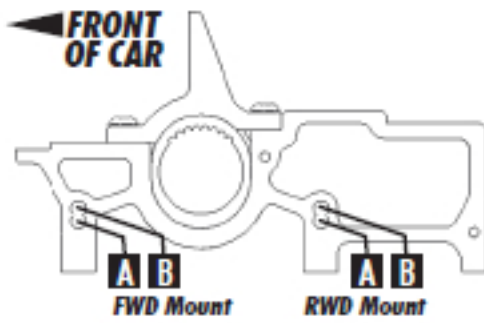

Motor	Gear	Notes
TEAM WAVE 10.35	100 / 42	4.6 OVERALL RATIO

Body & Wing
LIGHTWEIGHT MAZDA SPEED6

Battery
REEDY LIPO