



# Catalogue



Distributors of Quality  
Model and Hobby  
Products

**TEAM LOSI**

**Revolution Motors  
Sweep 1990 R.O.A.R.  
Monster Truck Nationals**

# POWER SURGE



**More than what meets the eye!**

It takes more than flashy stickers or bargain prices to make reliable, winning R/C racing motors. It takes top quality materials, constant testing and above all, unequaled workmanship. Team Losi Revolution modified racing motors have it all! Race proven quality is our most important product . . . Quality that has won every Modified 2WD off road national championship in 1989.

**...THEY'LL KNOW WHAT HIT THEM!**



**JR's Choice:**

The perfect balance of torque, RPM and most important a broad driveable power band makes this the best motor for most off road buggies, cars and trucks. Developed by World Champion Gil Losi Jr. for both 6 cell and 7 cell competition. As Gil says, "I never leave home without it!"



**Motown Missile:**

The motor that took Detroit and the R.O.A.R. Nationals by storm! This is the motor that powered Jack Johnson to the Top Qualifier spot and ultimately a runaway win in 2 wheel drive modified. The Motown Missile is raw horsepower from the second you pull the trigger. Definitely not for the weak at heart.



**MTM-Monster Truck Motor:**

The ideal power plant for Monster Truck racing as evidenced by it powering both the top qualifier and winner of the N.O.R.C.A. U.S. Nationals. Plenty of torque to get those big tires moving yet a smooth band that won't run out of top end. The MTM does not require those special "itty-bitty" pinions or "humongus" spurs which rob power.



**Super-Stock:**

All "New" for the 90's, the famous #6060 super stock Motor features a radical new armature design, the latest in high density magnets, ultra high density brush material, long life bushings and custom end bell hardware. To insure consistant race winning performance, each motor goes thru a multi-step break in by World Champion Racers.

**TEAM LOSI  
PERFORMANCE**

**TEAM LOSI TEAM LOSI PRODUCTS ARE AVAILABLE AT ALL GOOD MODEL SHOPS**

DISTRIBUTED BY CML DISTRIBUTION

# Contents



## TEAM LOSI

The JR-X2 – JR-X2 Accessories – JRX-Pro – JR-XT – JR-XT Accessories – Team Losi, Naturals Racing Tyres – Racing Revolution Motors – Team Losi Prime Time Cells – Team Losi Accessories

4

## YOKOMO

The Super Dogfighter YZ870C – Dogfighter Optional Parts – Hotlaps Racing Tyres – Yokomo Racing Accessories

11

## NOVAK ELECTRONICS AND FUSION SPEED

Noval Electronic Speed Controllers – Novak Receivers – Novak Peak Chargers – Team Novak Accessories

16

## PRO-LINE

Pro-Line Off Road Tyres – Pro-Line Wheels – Pro-Line Off Road Accessories – Pro-Line On Road Tyres – Pro-Line On Road Accessories – Pro-Line Monster Truck Tyres & Accessories – Pro-Line Accessories

20

## ANDY'S R/C PRODUCTS

Andy's 1/10th and 1/12th Lexan Bodies – Andy's 1/10th Off Road Performance Components

26

## SCAT RACING PRODUCTS AND THE COVERITE BODY SHOP PAINTS

Scat Motor Cleaning and Lubricant Fluids – Scat Gear Charts – Coverite Ozone Friendly Lexan body spray – Coverite Body Decals

28

## JAMMIN' JAY HALSEY RACING PRODUCTS

Jammin performance Motor and Body accessories – Jammin' Jay Halsey Hats, Shirts and Stickers

30

## SPEED MODEL, MODEL MOTOR SPORT AND CML ACCESSORIES

Speed Model Custom Racing Parts – Model Motor Sport Race Winning Components – CML Accessories

32

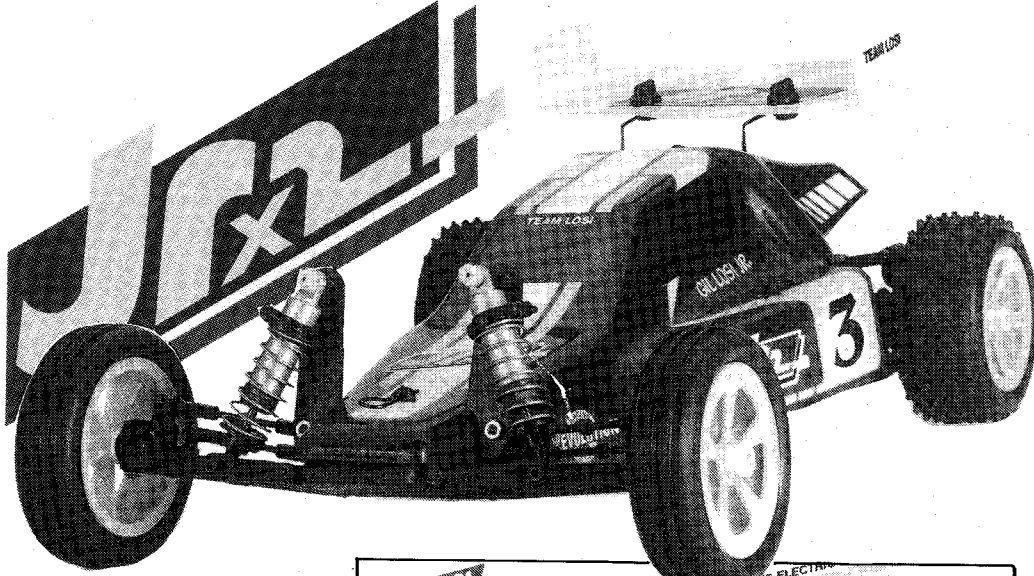

**JR-X2 FEATURES:**  
 Unique Losi 5 Link Suspension System  
 Carbon Fibre Graphite Composite Chassis  
 Precision Stainless Steel Ball Bearings  
 Efficient Low Rotating Mass Transmission  
 Internally Pressurised Oil Filled Shock Absorbers  
 Real Rubber Off Road Tyres and Light Weight Wheels  
 Wide Track Front End with Rack Type Steering

The JR-X2 is a dramatic winning edge. The LRM (low rotating mass) transmission features 49 pitch gears moulded from self lubricating materials specially formulated for low friction and durability. The 2.18 to 1 final drive ratio is lower than most others and allows selecting the correct gear ratios for the new breed of hot modified motors along with the proper ratios for stockers.

The new Losi 5-Link rear suspension handles all types of track conditions and features unique universal/slider drive shafts.

**JR-X2 Instant Winner! ...just add driver\* Why JR-X2?**

The JR-X2 is the product of many years of R/C car racing experience. It incorporates the many little things that helped me win 4 World Championships and numerous major titles around the world. The highly tested and developed design will help you be successful against the toughest competition GIL LOSI JR.

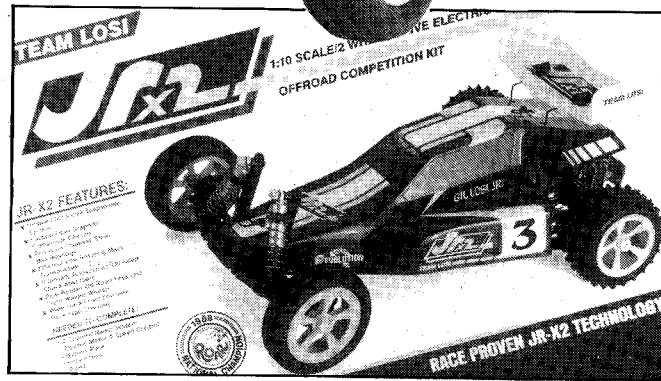

**TEAM LOSI JR-X2 Optional Extras**

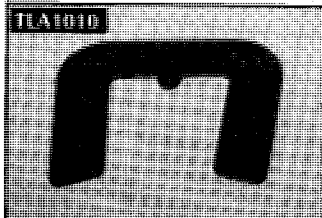

**TLA 1010 Monster Truck/Buggy Front Shock Tower**

This is used in conjunction with rear shocks to give the front suspension more travel, enabling it to handle rough ground easier.

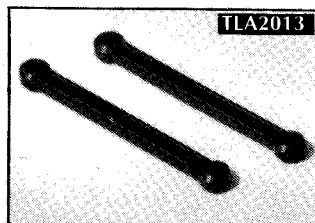

**TLA2013 Rear Toe-in Links (.050 shorter)**

Shorter links to give extra toe in on the rear. Use when on slippery/low traction tracks as they provide more stability to the rear.

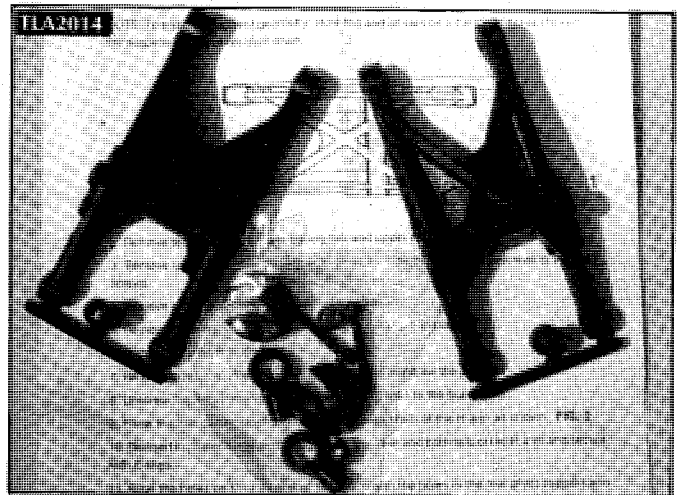

**TLA2014 H-Arm Conversion Set  
TLA2016 Rear Pivot Pin Support Set**

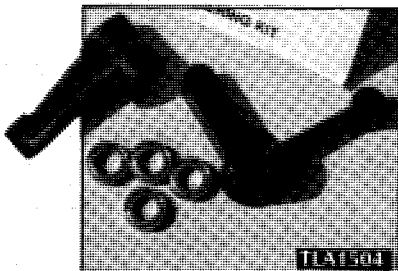

**TLA1504 Ball Bearing Steering Kit**

Comes with four bearings to give your steering that silky smooth action.

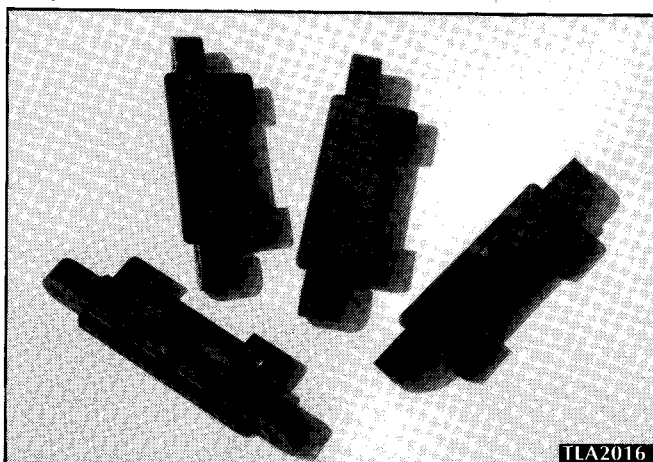

**Rear Toe-In, Anti-Squat and H-Arm Selection Information**

Two of the most important yet subtle suspension tuning adjustments in a car are the rear suspension toe-in and anti-squat. To provide for these fine tuning adjustments, the Nationals kit includes a selection of rear pivot supports to cover a variety of track conditions. Each of the supports offers a different combination of

toe-in and anti-squat. When a car undergoes hard acceleration, the rear end has a tendency to drop. When this happens, the car loses some of its on-power traction. In order to overcome this, the anti-squat ability of the car must be increased. The drawback is that as the anti-squat increases the forward traction, it also decreases the off power traction. If the rear end of the car has a tendency to 'skate' or is unstable, then adding toe-in would give the car more straight line stability and help solve this problem. The trade-off to having toe-in is a decrease in straight line speed and the car will not carry speed through the turns as well. Each adjustment to a car creates a trade-off. Performance is gained in one area and lost in another. The trick is to find the best set of trade-offs for your driving style.

Both the H-arm and five link suspensions use the same method to induce toe-in, but the means to create anti-squat differ. With H-arm suspension, anti-squat is controlled by tilting the rear inner hinge pin. On the five link suspension, the anti-squat is controlled by the rear trailing links. By tilting the inner hinge pin on the five link, bump steer may occur in the rear wheels. Under some track conditions this might be an asset.

The suggestions given in this kit should be used only as general guidelines. There are so many variables in a car that they cannot possibly be listed in a simple instruction sheet. Go to the track, try out various combinations of set-ups and get a feel for what each one does to the handling of the car.

The pivot supports provided in this kit are secured to the chassis exactly as the stock supports are. On the back of each pivot support, there will be a number. This number corresponds to the style of the pivot support. Refer to the chart provided to determine the toe-in and anti-squat for each support. On the bottom of the H-arm you will find a letter and an arrow. The arrow points to the front of the car and the letter designates left and right. You'll notice that the arms are swept back slightly and that there are a number of holes for shock placement. If you reverse the arms so that they are swept forward, you will shorten the wheelbase and speed up the reaction time of the car. If you raise the shock placement, the car will handle big jumps better

and be less forgiving in chop and turns. Use the adjustments provided, experiment and find out which combination works best for you.

NOTE: To ensure consistent geometry, store this and all cars on a car stand or riser to keep suspension free of residual strain.

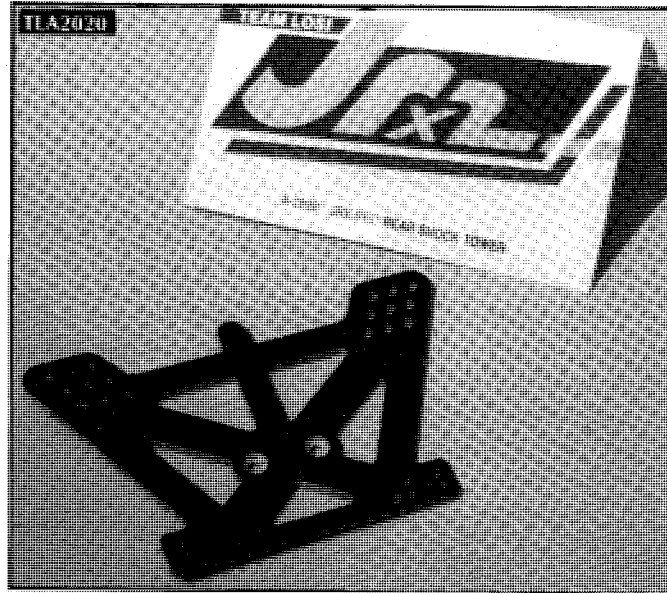

**TLA2020 Pro Rear Shock Tower**

An improved rear shock tower with increased adjustment for both shocks and upper links to help fine tune your car

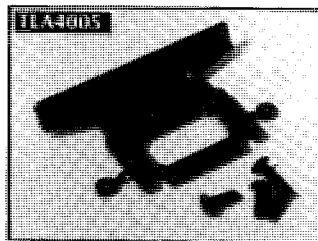

**TLA4005 Mini Bumper Kit**

This bumper fits between the chassis and the front suspension, and has a lip moulded into it, keeping the chassis totally flush.

**TLA4040 Long Graphite Chassis**

This chassis is about an inch longer and has 30° extra kick up, allowing it to be more stable over rough ground.

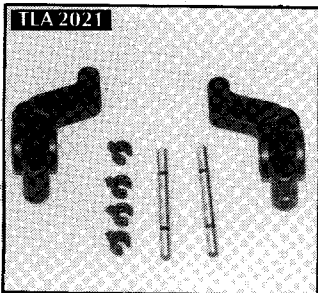

**TLA2021 Rear Hub Kit for H-Arm**

This is an improved hub carrier with more adjustment use with H-Arm Suspension



**TEAM LOSI SHOCK FLUID**

Available in seven easy ID colours. Seven coded weights 100% synthetic will not attack plastic or swell O-Rings. Available in handy assorted 5 pack or individual (5, 10, 20, 30, 40, 50, 70)  
 TLA 520 5wt oil  
 TLA5021 10wt oil  
 TLA5023 20 wt oil  
 TLA5204 30wt oil  
 TLA5205 40wt oil  
 TLA5206 50wt oil  
 TLA5207 70wt oil  
 TLA5210 5 pack (5, 10, 20, 30)

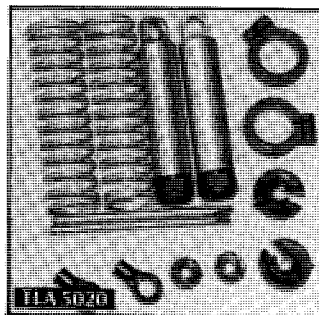

**TLA5020 X-Long Rear Shocks (1.2" travel)**

For more travel providing improved ride over rough ground.

**TLA2024 Rear Shock Tower Spacer**

This spacer helps align the shocks for a better angle during action.

**JR-X2 Springs**

- TLA5100 Front Springs (Soft) (Kit)
- TLA5101 Front Springs (Medium)
- TLA5102 Front Springs (Firm)
- TLA5103 Front Springs (X-Soft)
- TLA5105 Rear Springs (Soft) (Kit)
- TLA5106 Rear Springs (Medium)
- TLA5107 Rear Springs (Firm)
- TLA5108 Rear Springs (X-Soft)
- TLA5121 Front Progressive Springs
- TLA5141 Rear Progressive Springs (JR-XT)

All the above springs are stainless steel and are colour coded for easy use.

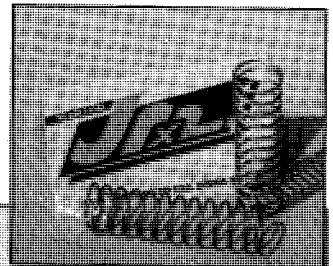

6

### JR-X2 Wheels

These wheels feature a unique star/spoke design and are exceptionally strong and lightweight. They are available in four different colours, Hot Orange, White, Wild Red and Bright Yellow

TLA7000 Front Rims - Orange

TLA7101 Rear - Orange

TLA7001 Front Rims - White

TLA7102 Rear - White

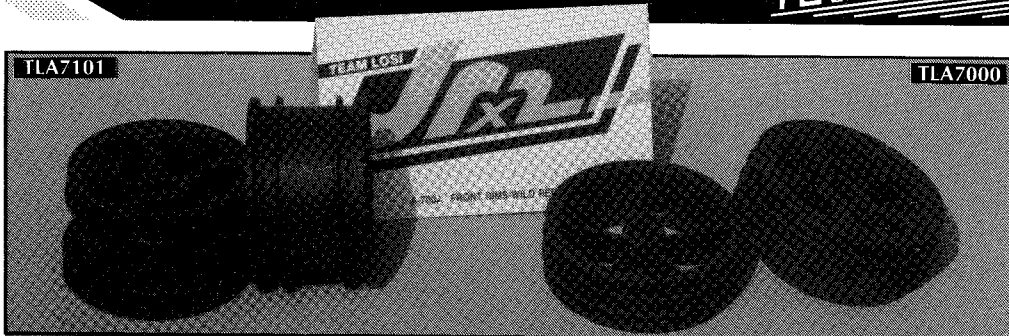

TLA7002 Front Rims - Red  
TLA710 Rear Rims - Red  
TLA7003 Front Rims - Yellow  
TLA7103 Rear Rims - Yellow

### TLA0901 Pro Performance Kit

This kit is available to all JR-X2 owners, and it allows you to convert your existing JR-X2 to the one which Jack Johnson powered to victory in the 1989 Roar 2WD Nationals, and the one which Team Losi had qualify 2nd and finish 4th, 8th and 10th at the 1989 World Championships in Australia. This kit is only a conversion and not a car outright, you must own a JR-X2 before you purchase one.

The kit consists of the following: Monster truck/buggy shock tower, rear shocks, H-Arm conversion, anti-squat and toe-

in blocks, pro rear shock tower, long chassis, longer upper links, long pro body, comprehensive assembly and tuning guide by Jack Johnson himself. Finally as a special bonus to JR-X2 owners who purchase this kit Team Losi have included a free JR's choice 17 Double modified motor (worth £45.00) to power your car to victory.

### CUSTOM PAINTED BODIES

#### TLA8001 JR-X2 Custom Painted Body

These bodysells are painted with the latest airbrush techniques and involve the latest neon and flourescent colours currently available.

#### TLA8003 JR-X2 Pro Long Body Custom Painted



quality carbon fibre graphite composite chassis has now been made longer for extra high speed stability, and the 30° kick up at the front makes steering more responsive and accurate. Four track tuned rear pivot supports are included with the

PRO for multi adjustable toe in and anti squat. The multi adjustable rear bulkhead means geometry can be fine tuned for any track.



Long front shock absorbers are now a must on any competitive 2WD car and the JR-X2 PRO has these item as standard! The rear 'H' arm suspension makes sure that the PRO rides the bumps with ease. The unique centre mounted bearing supported transmission utilises a limited slip, low rotating mass differential with a new specially engineered spur gear. All the parts are available separately with most being included in the TLA 0901 Pro Package.

### JRX PRO

The JRX PRO is the latest development to come from Team Losi. Based on the highly acclaimed and successful JR-X2, the PRO incorporates all of the best race winning features that

have been designed over the past few years. This car has a longer chassis, improved shock location and travel, H-Arm suspension, new improved rear hub carriers with more adjustment. The high

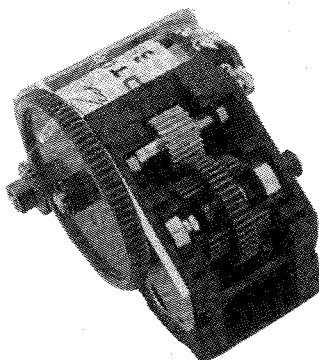

# JR-XT

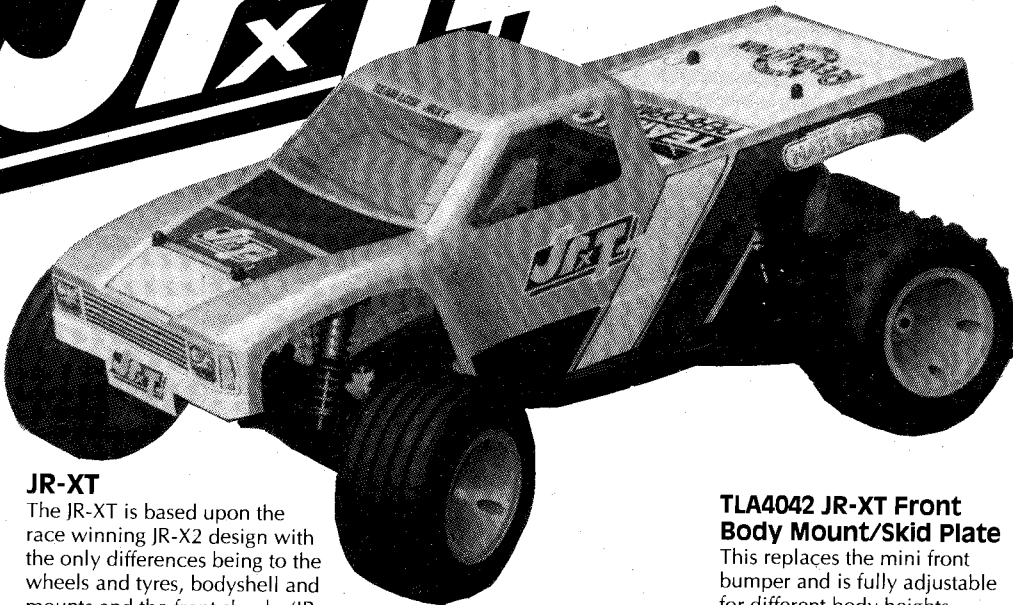

### JR-XT

The JR-XT is based upon the race winning JR-X2 design with the only differences being to the wheels and tyres, bodyshell and mounts and the front shocks (JR-XT uses rear shocks on the front for extra travel). With this sort of race pedigree its really not surprising it wins!

### WHEELS

The wheels are three piece nylon ones and are available in White, Red, Orange and Yellow.

TLA7050 Truck Front Rims - Orange  
TLA7150 Rear - Orange  
TLA7051 Truck Front Rims - White  
TLA7151 Rear White  
TLA7052 Truck Front Rims - Wild Red

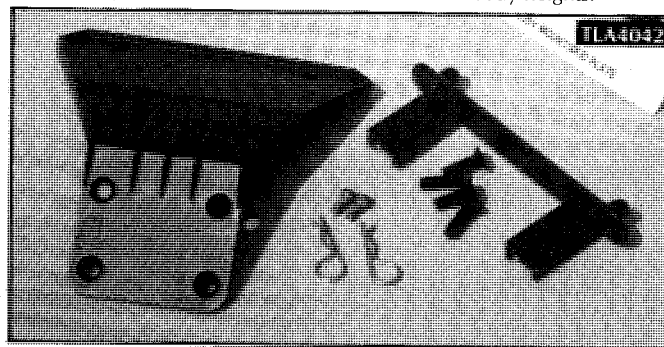

### TLA4042 JR-XT Front Body Mount/Skid Plate

This replaces the mini front bumper and is fully adjustable for different body heights.

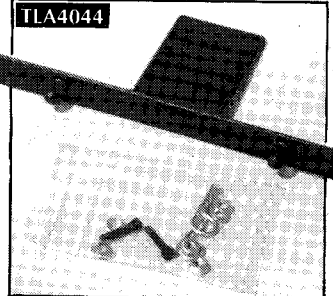

### TLA4040 Graphite Chassis (Long)

### TRUCK TYRES

Truck tyres are made from the same compound as the JR-X2 range (HT) and give superb performance.

TLA7500 Monster Truck Front Tyres - Ribbed  
TLA7600 Monster Truck Rear Tyres 6 Row Spiked  
TLA8010 JR-XT Stadium Truck Body  
TLA8011 JR-XT Stadium Truck Body Custom Painted  
TLA8111 JR-X2 Dirt Shield Set. This is two lexan angles, which are fixed to the chassis to eliminate dirt build up due to the high nature of the bodyshell.  
TLA8302 JR-XT Decal Sheet.

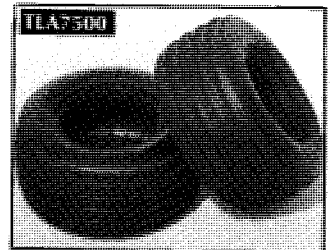
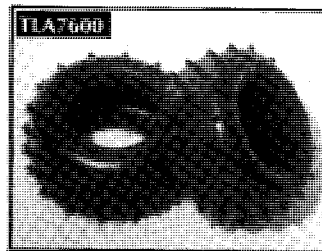
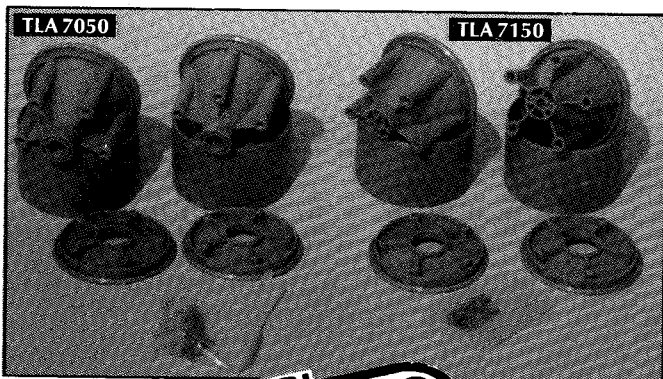

### TLA7200 Ribbed Front (K) (Kit Type)

### TLA7201 Ribbed Front (HT)

(all purpose front tyre, excellent on most surfaces)

### TLA7210 Stagger Rib Fronts (K)

### TLA7211 Stagger Rib Front (HT)

(this tyre design offers a little more grip over the ribbed working especially well on dirt, short grass surfaces).

### TLA7300 4 Row Spike Rears (K) (Kit Tyre)



### Team Losi Natural Rubber Racing Tyres

Team Losi naturals are the

(K) = Kit, Long Wear Compound  
(HT) Soft (Silver Dot)  
High traction

ultimate connection between your car and the racing surface. "Naturals" are individually developed and constructed to deliver maximum traction and handling for all conditions.

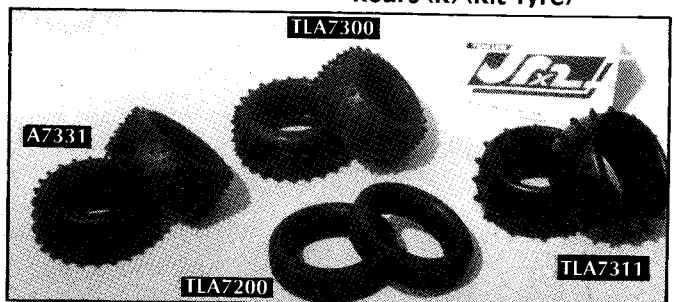

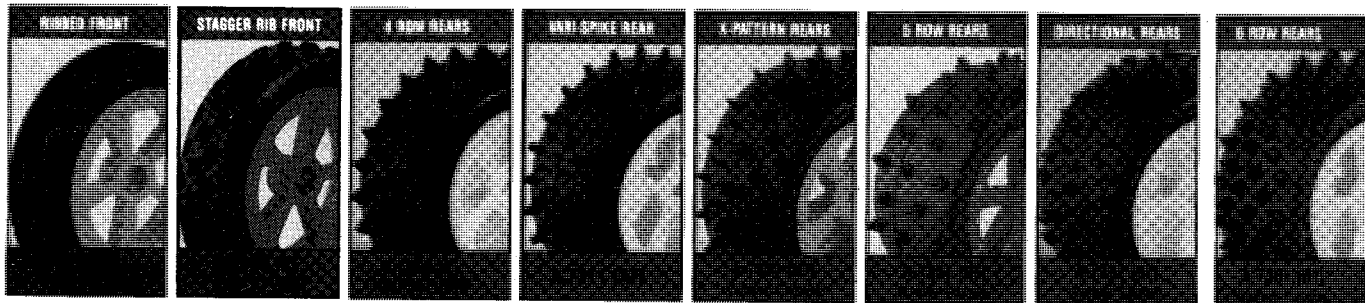

**TLA7301 4 Row Spike Rears (HT)**

(all purpose design tyre excellent on most surfaces)

**TLA7311 6 Row Vari Spike Rears (HT)**

(A variety of spike size make up this tyre, with large spikes going to smaller spikes in the centre, excellent on short grass.

**TLA7321 'X' Pattern Rears (HT) (Cushion Carcass)**

This tyre features a unique centre row of 'X' cross spikes, with spikes either side. This design coupled with Team Losi's cushion carcass inner webbing make this tyre superb on dirt and hard surfaces. They are particularly effective when the spikes are cut to half height for extra surface area contact.

**TLA7331 5 Row Spike Rears (HT) (Cushion Carcass)**

This tyre has the same spike as the kit tyre but at more spread out intervals in its tread pattern, making it excellent on grass and in muddy conditions as they do not clog up.

**TLA7341 Directional Pattern Rears (HT) (Cushion) Carcass**

These tyres are superb on hard dirt surfaces as they have a wide surface area contact with the track, as the tyre pattern consists of small rectangular blocks designed with special direction when in contact with the track.

**TLA7351 6 Row Spike Rears (HT) (Cushion Carcass)**

This is a multi spike tyre and works excellently on grass and soft dirt .



**MODIFIEDS**

Modified motors begin with the finest quality wire to produce the best short resistance armature available. All commutator connections are welded – not crimped or soldered and the commutator is diamond trued to a mirror finish. The armature is dynamically balanced and set into the motor casing with its supercharged forged magnets and held in perfect alignment by precision ball bearings. The current is conducted via high efficiency Team Losi silver hard brushes.

**SUPERSTOCK**

Superstock motors are built from select stock motors which are broken-in and solution-dipped to seat the brushes to maximise commutator contact. Bushings are reset and armature alignment adjusted to eliminate parasitic drag. Brush hoods are sized to eliminate sticking brushes. Brush shunts are re-routed for optimum reliability : Brush springs are re-arc'd for tuning pressure : Timing is set at the maximum allowed : Magnets are zapped and every motor is dyno tested.

**TL6060 Superstock (27T)**  
(not just an out of the box

motor, this super performer features all the custom 'tweaking' allowed within the rules).

**TL6040 Revolution II**

(21 Double, Dry Magnet) (superb 2WD or Pro 10 motor featuring a smooth power band with low current draw).

**TL6046 Revolution IV**

(19 Double, Dry Magnet) (Again excellent in both 2WD/ Pro 10 when grip is good, also a perfect motor for the first timer).

**TL6054 Revolution 'Oval'**

(17 Triple, Dry Magnet) A very good all round motor with not uncontrollable handling or high amp draw).

**TL6056 Revolution 'Insane'**

(15 Double, Dry Magnet) (Regarded at one time as an insane wind the 15 Double has these days become rather mild, however when applied to the right car/track combination can still deliver the goods).

**TL6058 Revolution 'Brutus'**

(16 Triple, Dry Magnet) (A motor to suit almost any car or track. More a 4WD motor, but well suited in well set up 2WD cars).

**TL6058 Revolution 'Killer'**

(14 Double, Dry Magnet). (Racing is given a whole new meaning with this motor, as you race to the death for the prize of winning).

**TL6070 Revolution 'Lighting Drag'**

(11 Triple, Dry Magnet) (A radical power plant, this is Revolutions lowest wind motor, a definite 4 WD motor, for ultimate wheel spinning).

**TL6101 Revolution Wet Mag II**

(18 Triple Wet Magnet) (A nice safe wind motor well suited to 2WD, or Pro 10 on high traction surfaces).

**TL6102 Revolution Wet Mag IV**

(16 Quin Wet Magnet) (A unique wind, this motor produces superb torque for that 4WD pulling power. Good in Yokomo cars).

**TL6103 Revolution Juniors choice**

(17 Double, Wet Magnet) (Probably the most popular wind in any manufacturers listing. This one is Gil Losi Jr's own personal choice for a well set up JR-X2. Also works wonders in Yokomo 4WD cars when correctly geared).

**TL6104 Revolution MTM**

(19 Double, Wet Magnet) (Specially wound for monster truck racing. This motor produces all the necessary torque and rpms required by Monster Truck racing).

**TL6105 Revolution Daytona Oval**

(13 Triple, Wet Magnet) (A rising star in the Revolution range. This motor appears to be brilliant in Cats/Yokomo's/Mids, if you have the nicads to cope!).

**TL6106 Motown Missile**

(12 Single, Wet Magnet) (Jack Johnson's own choice of motor when he won the 89 2WD Nationals. Have you the 'bottle' to make your car a missile?).

**TL6107 On Road Special**

(11 Quad, Wet Magnet) (Pro 10 motor for high grip tracks or extremely large ones, works also in 4WD).





**TL6108 Revolution 'Big Ed'**  
(15 Quad, Wet Magnet)  
**TL6109 Revolution 'Super Insane'**  
(11 turn, wet)

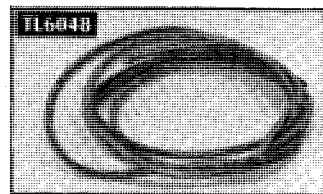
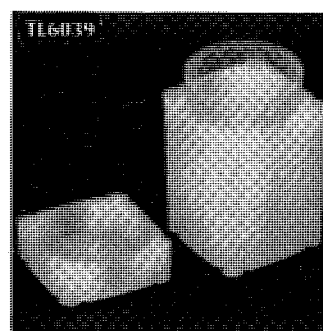
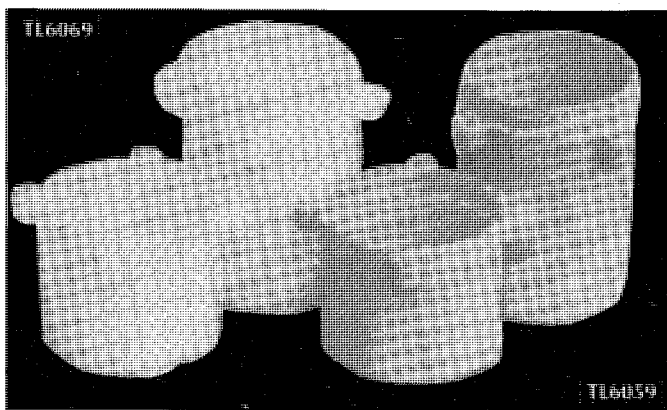
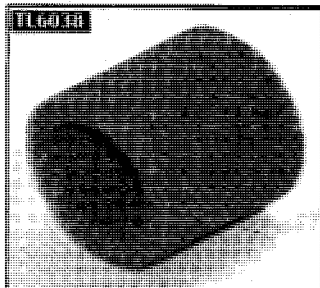

**Motor Accessories**

- TL6038 Foam Motor Cover
- TL6039 Motor Storage Tub
- TL6041 Mod Silver Shunted Brushes (Hard)
- TL6045 Pre-Bent Brush Springs
- TL6048 Silicone Wire, 2' each Red and Blue
- TL6055 Comp-Cut Silver Shunted Brushes
- TL6059 "Motor Safe" W/storage Chamber
- TL6061 "Hi Pro" Soft Shunted Brushes
- TL6069 "Motor Safe II" W/O Storage

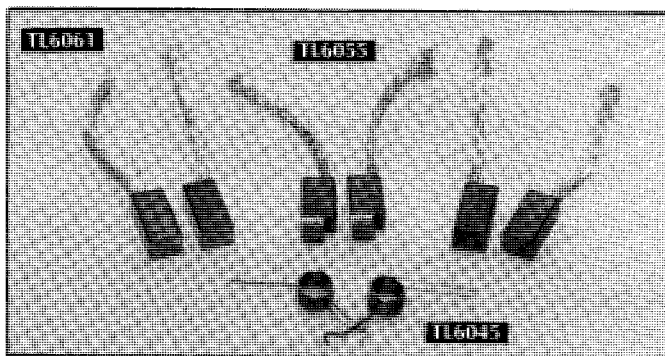

- TL4024 64 Pitch Pinion 24 Teeth
- TL4025 64 Pitch Pinion 25 Teeth
- TL4026 64 Pitch Pinion 26 Teeth
- TL4027 64 Pitch Pinion 27 Teeth
- TL4028 64 Pitch Pinion 28 Teeth
- TL4029 64 Pitch Pinion 29 Teeth
- TL4030 64 Pitch Pinion 31 Teeth
- TL4032 64 Pitch Pinion 32 Teeth
- TL4033 64 Pitch Pinion 33 Teeth
- TL4034 64 Pitch Pinion 34 Teeth
- TL4035 64 Pitch Pinion 35 Teeth
- TL4036 64 Pitch Pinion 36 Teeth
- TL4096 64 Pitch Spur 96 Teeth
- TL4100 64 Pitch Spur 100 Teeth
- TL4104 64 Pitch Spur 104 Teeth
- TL4108 64 Pitch Spur 108 Teeth

**TEAM LOSI  
PRIMETIME  
SELECTED SANYO CELLS**

**TEAM LOSI PRIMETIME  
MATCHED NICADS**

**Team Losi Primetime  
Matched Nicads**

Team Losi 'Primetime' matched nicads are individually charged-and-discharged on state-of-the-art electronic equipment, then matched into sets according to capacity and discharge characteristics. This proven method of matching results in nicads that provide superior performance. Remember a pack is only as good as its worst cell!

- TL6072 Primetime Matched SCR
- TL6075 Primetime Matched SCE

**Gears**

All pinions are machined individually to ensure concentricity and pressure angle, they use 5.40 grub screws which have larger threads thus preventing stripping, they come with an

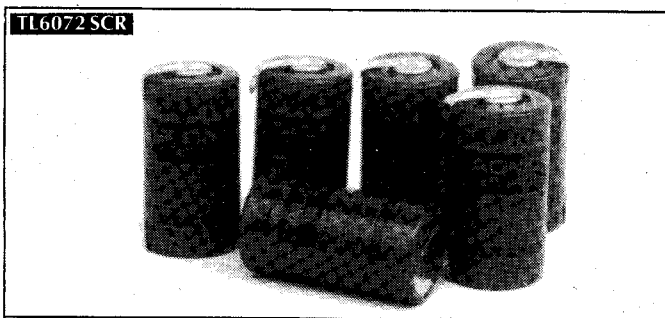

allen key and are hardened. Spurs are moulded from impregnated thermo-plastic with self lubricants and have a gear chart included. They are available in 32DP/48DP/64DP.

**64 Pitch**

- TL4018 64 Pitch Pinion 18 Teeth
- TL4019 64 Pitch Pinion 19 Teeth
- TL4020 64 Pitch Pinion 20 Teeth
- TL4021 64 Pitch Pinion 21 Teeth
- TL4022 64 Pitch Pinion 22 Teeth
- TL4023 64 Pitch Pinion 23 Teeth

**48 Pitch**

- TL4114 48 Pitch Pinion 14 Teeth
- TL4115 48 Pitch Pinion 15 Teeth
- TL4116 48 Pitch Pinion 16 Teeth
- TL4117 48 Pitch Pinion 17 Teeth
- TL4118 48 Pitch Pinion 18 Teeth
- TL4119 48 Pitch Pinion 19 Teeth
- TL4120 48 Pitch Pinion 20 Teeth
- TL4121 48 Pitch Pinion 21 Teeth
- TL4122 48 Pitch Pinion 22 Teeth
- TL4123 48 Pitch Pinion 23 Teeth
- TL4124 48 Pitch Pinion 24 Teeth
- TL4125 48 Pitch Pinion 25 Teeth
- TL4126 48 Pitch Pinion 26 Teeth
- TL4127 48 Pitch Pinion 27 Teeth
- TL4128 48 Pitch Pinion 28 Teeth
- TL4129 48 Pitch Pinion 29 Teeth
- TL4130 48 Pitch Pinion 30 Teeth
- TL4178 48 Pitch Spur 78 Teeth
- TL4182 48 Pitch Spur 82 Teeth
- TL4186 48 Pitch Spur 86 Teeth

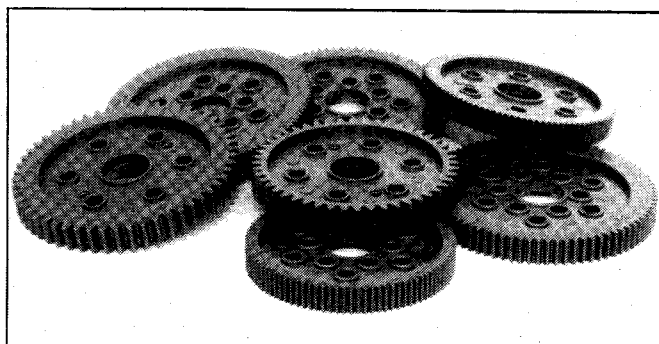

**32 Pitch**

TL4209 32 Pitch Pinion 9 Teeth  
TL4110 32 Pitch Pinion 10 Teeth

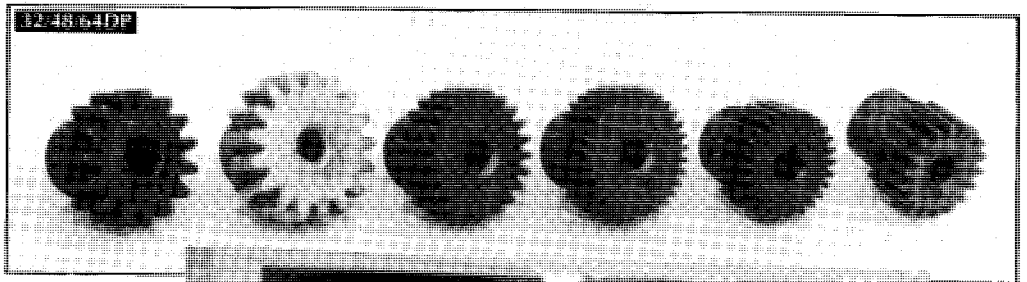
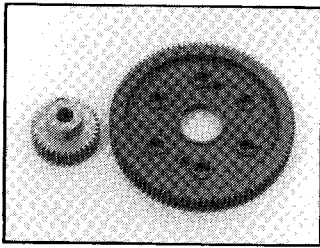

**GEAR ACCESSORIES**

- TL 4008 Ground 5.40 Pinion Wrench. (Fits all team Losi pinions enabling you to secure that all important pinion. Also fits some JR-X2 screws).
- TL4009 Ground 5.40 Replacement Tip
- TL4010 4.40 Hardened Setscrews (10) (For older Losi pinions and other American made pinions).
- TL4011 5.40 Hardened Set Screws (10) (For Losi pinions).
- TL4015 1/8" 'Hard' Diff Balls (8) (Fits RC10, dramatically reduced wear rate).
- TL4026 3/32" 'Hard' Diff Balls (12) (Fits JR-X2 Diff).
- TL4017 1/16" 'Hard' Diff Balls (8) (Fits JR-X2 Thrust race).

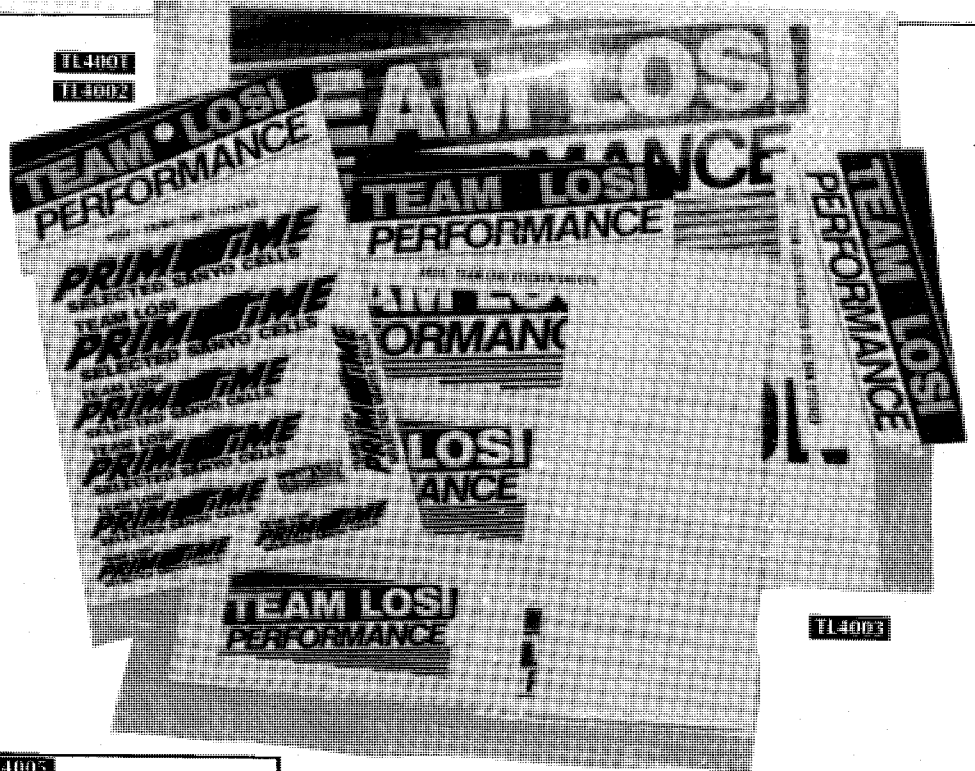

**RACING ACCESSORIES**

- TL3801 Tandem Body for Yokomo with FG Plate
- TL3091 'Team Losi' 'T' Shirt (S)
- TL3092 'Team Losi' 'T' Shirt (M)
- TL3093 'Team Losi' 'T' Shirt (L)
- TL3094 'Team Losi' 'T' Shirt (XL)
- TL3095 'Team Losi' 'T' Shirt (XXL)
- TL3097 'Team Losi' Racing Hat
- TL3911 'JRX-2' T-Shirt (S)
- TL3912 'JRX-2' T-Shirt (M)
- TL3913 'JRX-2' T-Shirt (L)
- TL3914 'JRX-2' T-Shirt (XL)
- TL3915 'JRX-2' T-Shirt (XXL)
- TK3816 'JRX-2' Racing Hat
- TL3920 'Team Losi' Banner (4ft)
- TL3921 'JRX-2' Banner (4ft)

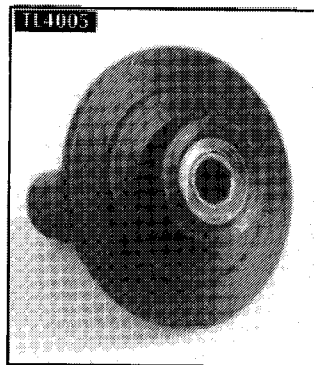

**RC10 Racing Accessories**

- TL4005 Machined Diff Tube W/Ball Bearing. (Reduces slop on diff shaft thus improving gear meshing and reducing stripping).
- TL4015 1/8" 'Hard' Diff Balls (8)
- TL7001 Dog Bone W/One-Piece Ends. (Improved design in hardened steel to reduce breaking).
- TL7008 Bell Crank Kit W/Bushings. (Two machined alloy bellcranks, mounted via bronze bushings on steel posts reducing unwanted slop).
- TL7009 Bell Crank Kit W/Bearings

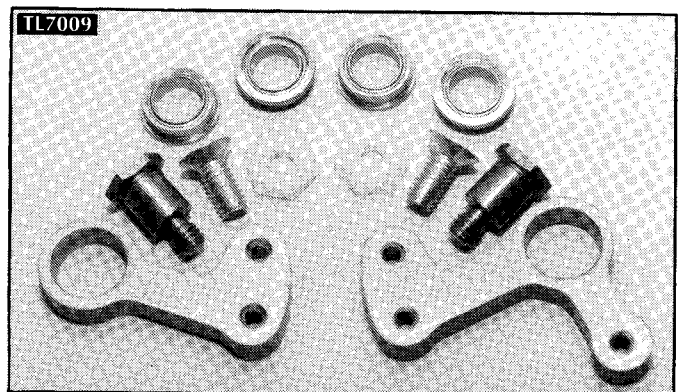

- TL4001 'Team Losi'/Revolution 'Side dam stickers
- TL4002 'Primitime' sticker sheets (2)
- TL4003 'Team Losi' sticker sheets (4)
- TL4004 'Revolution' sticker sheets (2)

**Tyres**

TL5027 Pro 10 Rear Tyres soft (Excellent in damp conditions, porous compound).

## Super Dog Fighter

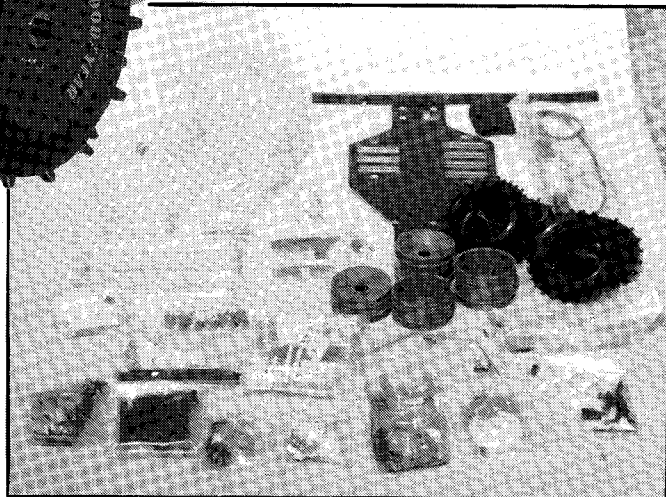
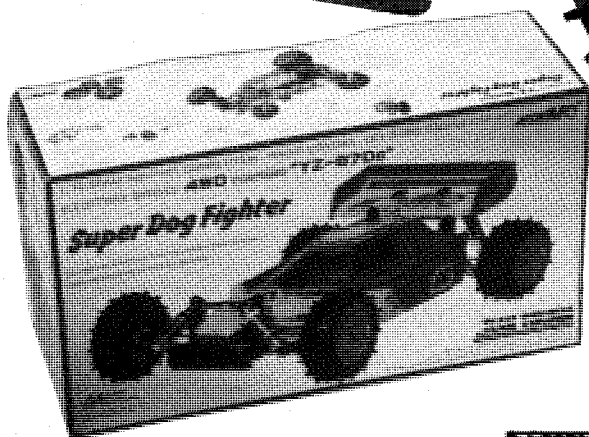

11

### YOKOMO YZ870C Super Dogfighter

#### Optional Parts

**ZC103/103U Protech Body and Undertray**  
Replacement body and tray. The protech is a body similar to full sized off road cars and is based on the RC10 body.

**ZC101A/102S Lightweight Standard Body and Undertray**  
**ZC103S/103US Lightweight Protech Body and Undertray**

**ZC107S Lightweight Wing**  
**ZC113 Chassis Plate Carbon Graphite**

A must for the serious racer. This chassis reduces flex, providing better handling by reducing chassis tweaks. It also offers a significant reduction in weight.  
**ZC201 Servo Crank Bearings**  
Two 3 x 6 Flanged Ball Bearings for the steering idler arm, replaces plastic bush.

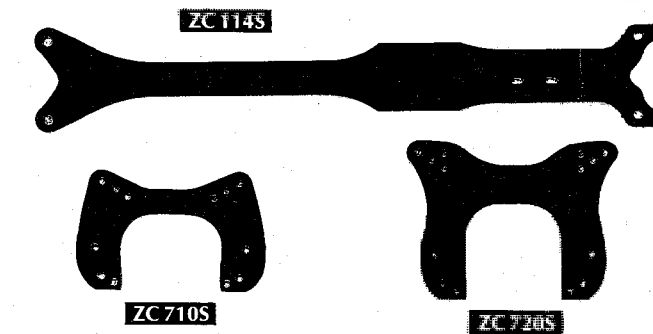

**ZC205/ZC208**, long rods, **ZC432 Front Wheel Hub**. This kit does not actually widen the track but only the wishbone length. IF used with **ZC431 8mm hubs** however this brings it to full width.

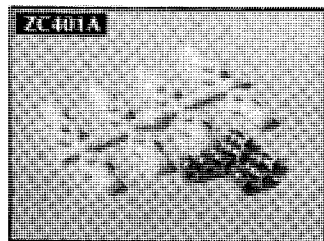

**ZC401A Aluminium Balls with Rod Ends.**  
Replaces the steel standard ones saving a considerable amount of weight.  
**ZC405 Front long suspension Arm Kit**  
Conversion Kit to widen the suspension arm. Consists of **ZC422 long driveshafts**.

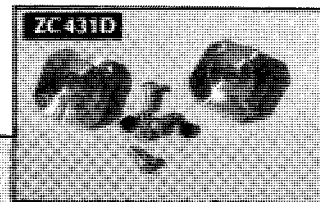
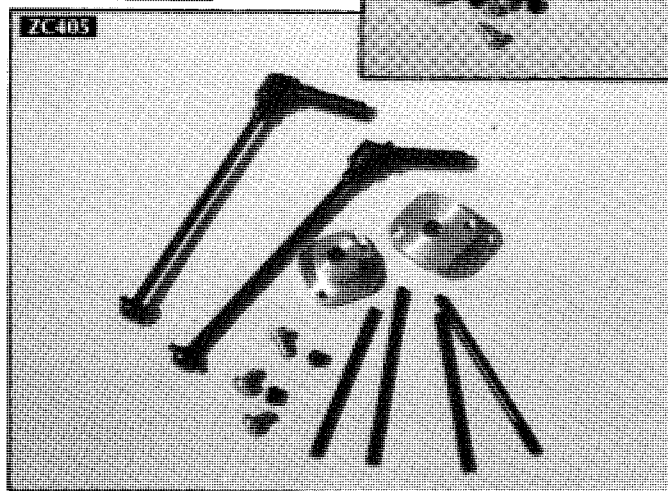

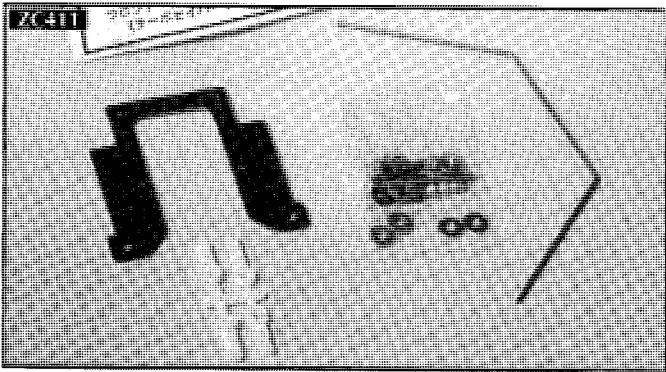

**ZC411 Front Anti-Roll Bar Kit**

Consists of a top plate to support the steering assembly and thrust races for the bell cranks, along with the roll bar.

**ZC114S Deck for Superdog Fighter (w/4 screws).**

**ZC431D Duralmin 8mm Wheel Hubs**

Same as stock ones but made from duralmin and machined for lightness. A must for reducing unsprung weight.

**ZC613-624 48DP Pinions**

13 Teeth to 24 Teeth Machine cut, precision made pinions come with spare grub screw – Hardened.

**ZC625 Set Screw Kit**

Two allen keys and grub screws for Yokomo pinions.

**ZC461S Super Centre Clutch Hub**

Gold anodised hub, which is fitted with two one way bearings for added strength and reliability.

**ZC641G Gear Adaptor**

Comes fully ballraced with two one way bearings and two outer

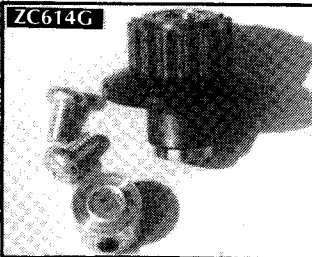

bearings. It is made from hardened steel and accepts Losi, Trinity and Kimbrough gears.

**ZC631G Fine Pitch Gear Adaptor**

This adaptor is fully ballraced and is used with the Fine Pitch

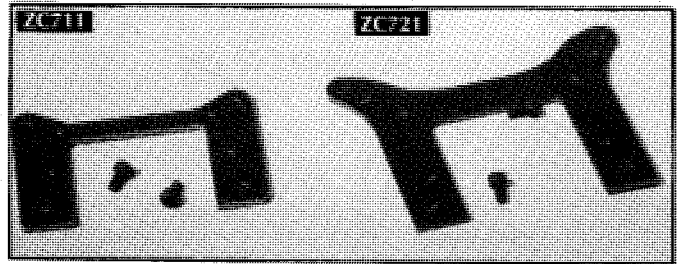
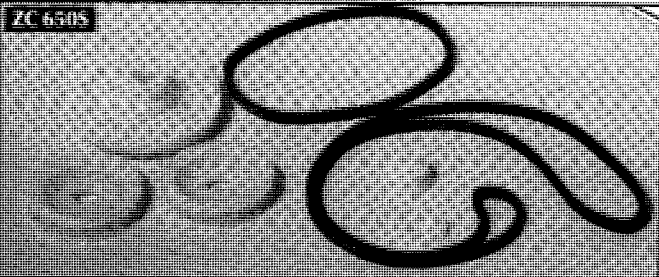

**ZC711 Graphite Front Shock Tower**  
Reduced flex for better handling

**ZC721 Graphite Rear Shock Tower**

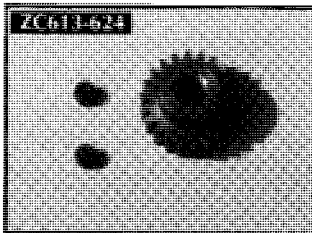
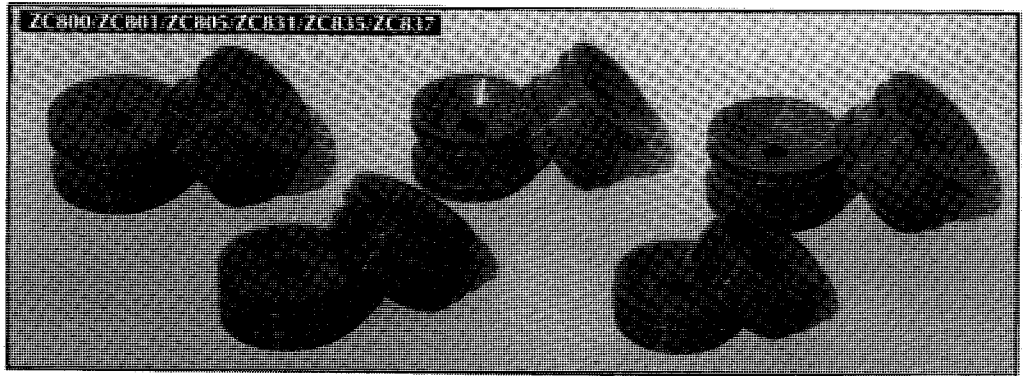

top speed. Consists of two diff. pulleys, front and rear belts, centre pulley, main gear sprocket in 86 Teeth.

**ZC732 Shock Setting Spacers**

Rent thickness spacers, with special tool for removal. Superb for all cars.

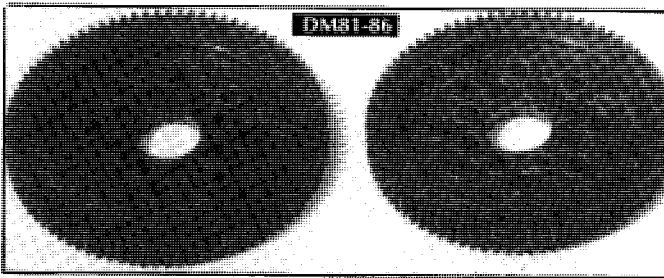

**Belt Conversion.**  
**ZC710S/720S Front and Rear Shock Towers**  
(New design for RC10 dampers)  
**DM81-86 Spur Gear Set**  
81T and 86T 48DP Spurs for ZC641G/ZC631G

**ZC650S Fine Pitch Belt Conversion**

Gives a much smoother running transmission, producing more

**Wheels (Standard size)**

ZC800 Front Narrow Wheels (Pink)  
ZC800W (White) Suitable for the narrow 2WD tyres available for those who use Yokomo wheels on 2WD cars.  
ZC801 (Pink)  
SC802W (White)  
ZC805 (Pink) ZC805W (White)

**HOTLAPS TYRES (For Standard Size Wheels)**

TF5S Front Narrow Pin Spike Tyre (Soft)  
TF5M Front Narrow Pin Spike Tyre (Medium)  
TF5H Front Narrow Pin Spike Tyre (Hard)

Excellent on most surfaces especially grass. Fits ZC800 narrow wheels making it an excellent tyre for 2WD racing.

TF8S Front Pin Spike Tyre (Soft)  
TF8M Front Pin Spike Tyres (Medium Kit Tyre)  
TF8H Front Pin Spike Tyre (Hard)

Good all round 4WD tyre suites fast flowing tracks with good smooth cornering ability.

TF9S Front Square Block Tyre (Soft)  
TF9M Front Square Block Tyre (Medium)  
TF9H Front Square Block Tyre (hard)

Pyramid block design provides exceptional grip on all surfaces especially dirt.

TR8S Rear Pin Spike Tyre (Soft)  
TR8M Rear Pin Spike Tyre (Medium) (Kit Standard)  
TR8H Rear Pin Spike Tyre (Hard)

A good all round tyre providing good grip in grass conditions without being too grippy so that power is wasted. Also good in mud, as it doesn't clog easily.

TR9S Rear Square Block Tyre (Soft)  
TR9M Rear Square Block Tyre (Medium)  
TR9H Rear Square Block Tyre (Hard)

A very popular tyre superb on both 2WD and 4WD especially dirt.

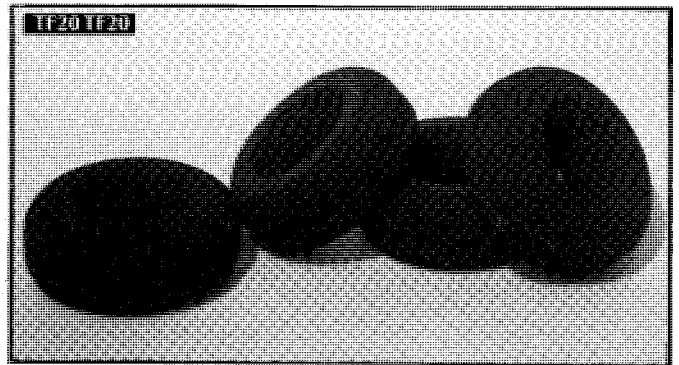
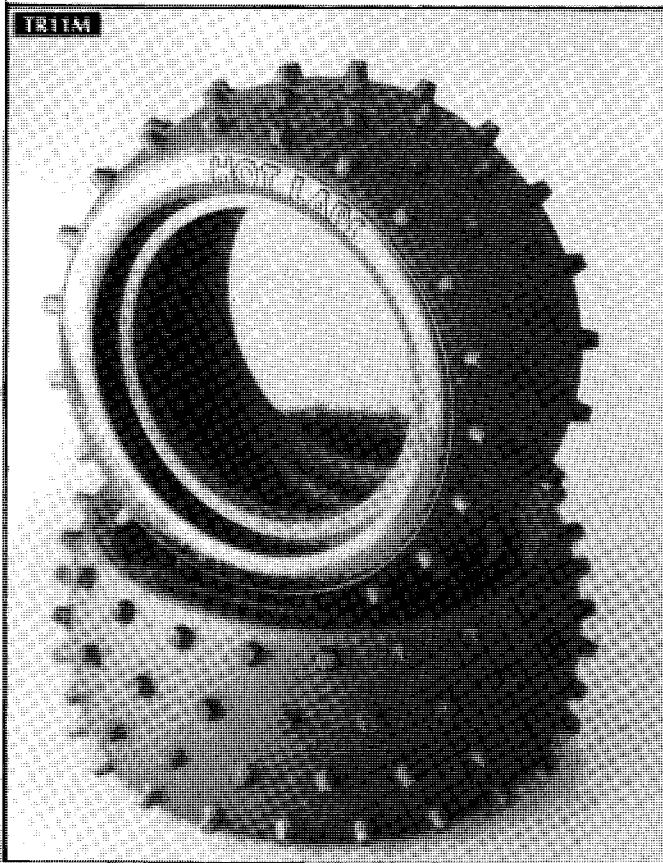

TR12S Rear Directional Pin Spike Tyre (Soft)  
 TR12M Rear Directional Pin Spike Tyre (Medium)  
 TR12H Rear Directional Pin Spike Tyre (Hard)  
 These tyres have a unique chevron design, arrow pattern, to cut through the terrain.

TF20 Front Sponge Tyres  
 Sponge tyre with centre groove works on all hard surfaces.  
 TR-20 Rear Sponge Tyre

**30 Series Wheels**  
 (Diameter 60mm)  
 ZC831/ZC831W (White)  
 Larger diameter wheels.  
 Compatible with 30 series tyres.

**30 Series Tyres**

TF310S Front Tyre Mini Pins (Soft)  
 TF310M Front Tyre Mini Pins (Medium)  
 TF310H Front Tyre Mini Pins (Hard)  
 Suitable on hard surfaces.

TF320S Front Tyre Short Spike (Soft)  
 TF320M Front Tyre Short Spike (Medium)  
 TF320H Front Tyre Short Spike (Hard)  
 Excellent for grass and muddy conditions.

TF330S Front Tyre Square Pins (Soft)  
 TF330M Front Tyre Square Pins (Medium)  
 TF330H Front Tyre Square Pins (Hard)  
 All round tyre for every surface dirt or grass.

TF340S Front Tyre Mix Pin (Soft)  
 TF340M Front Tyre Mix Pin (Medium)  
 TF340H Front Tyre Mix Pin (Hard)  
 This tyre as a mixture of pin and block spikes giving good controllable grip.

TF31S Rear Tyre Mini Pins (Soft)  
 TF31M Rear Tyre Mini Pins (Medium)  
 TF31H Rear Tyre Mini Pins (Hard)  
 Suitable for hard dirt/short grass surfaces.

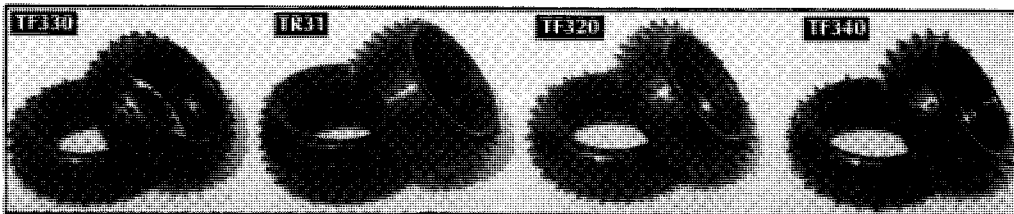

TR10S Rear Low Profile Square Block Tyre (Soft)  
 TR10M Rear Low Profile Square Block Tyre (Medium)  
 TR10H Rear Low Profile Square Block Tyre (Hard)  
 Same design as the TR9 range but are lower profile, offering more surface area contact.

TR11S Rear Low Profile Pin Spike (Soft)  
 TR11M Rear Low Profile Pin Spike (Medium)  
 TR11H Rear Low Profile Pin Spike (Hard)  
 Similar in design to the CAT tyre, with small cut spikes offering grip on short grass and dirt.

However certain smaller diameter tyres (CAT TR/TF9M) will stretch, offering a very low profile tyre indeed.  
 ZC835P/ZC835W (White)  
 Standard wheel suitable for Yokomo  
 ZC837P/ZC837W (White) (6mm offset)  
 Wheel offset making it suitable for use on the CAT as it makes the width legal.

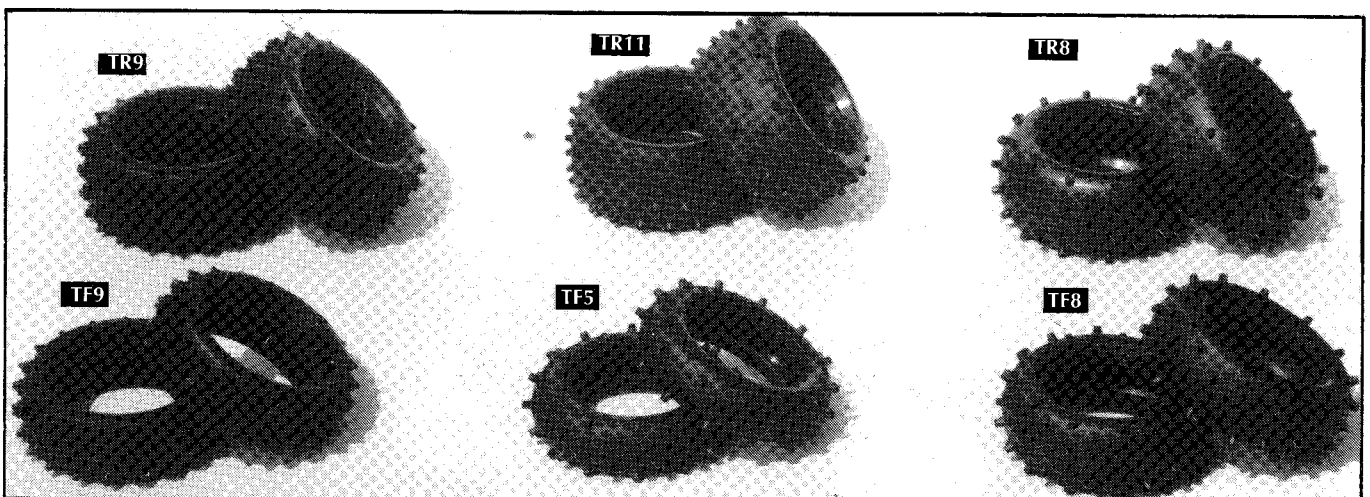

TR32S Rear Tyre Short Spike (Soft)  
 TR32M Rear Tyre Short Spike (Medium)  
 TR32H Rear Tyre Short Spike (Hard)  
 Excellent grass tyre 2WD or 4WD

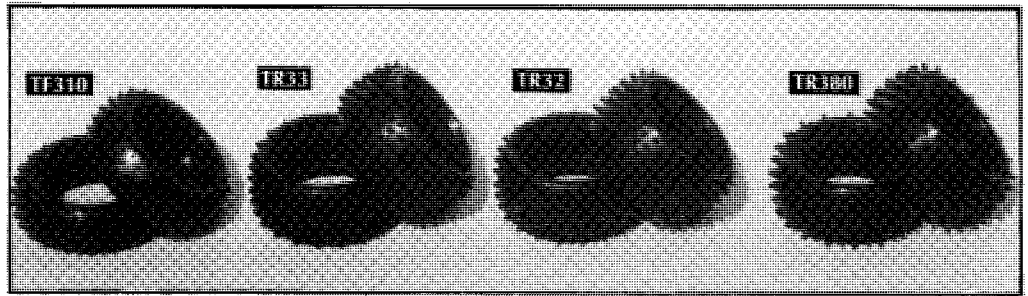

TR33S Rear Tyre Square Pins (Soft)  
 TR33M Rear Tyre Square Pins (Medium)  
 TR33H Rear Tyre Square Pins (Hard)  
 Again, like the front tyres, this design is superb on almost all surfaces.

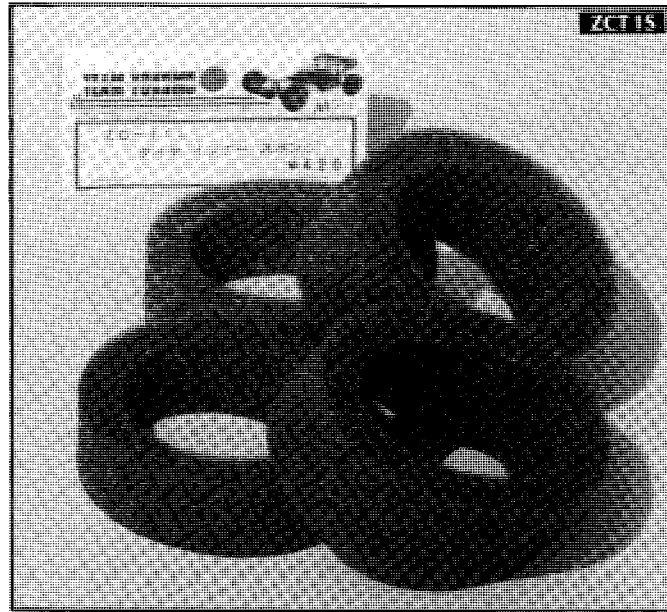

TR380S Rear Tyre Large Pins (Soft)  
 TR380M Rear Tyre Large Pins (Medium)  
 TR380H Rear Tyre Large Pins (Hard)  
 Suitable on grass and muddy conditions.

**ZCT1S Inner Tyre Sponge Inserts**

These are excellent when using soft compound tyres. Insert inside the tyre and they help retain the tyre profile while still having the soft compound.

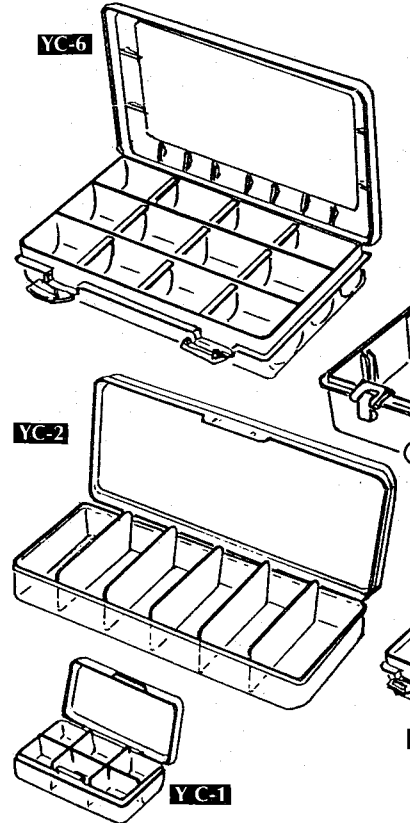

**YOKOMO ACCESSORIES**



ZCD4BL Super Dogfighter Decal (Blue)  
 ZCD4W Super Dogfighter Decal (White)  
 ZCD4BK Super Dogfighter Decal (Black)  
 ZCD4R Super Dogfighter Decal (Red)  
 ZCD4P Super Dogfighter Decal (Pink)  
 ZCD7 Wing Decals  
 Two decals for wing  
 ZCD8 Yokomo Large Decals  
 Two large decals for Pit Boxes etc.  
 YMBC Yokomo Battery Conditioner  
 Single boxed resistor with connector  
 YMBCM Battery Conditioner  
 5 resistors with clips

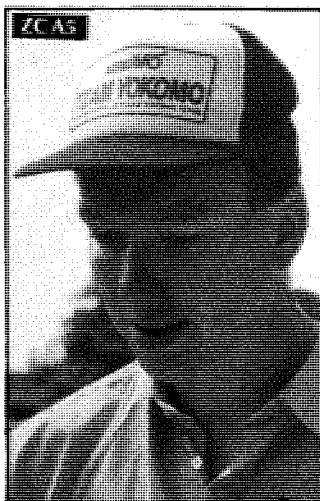
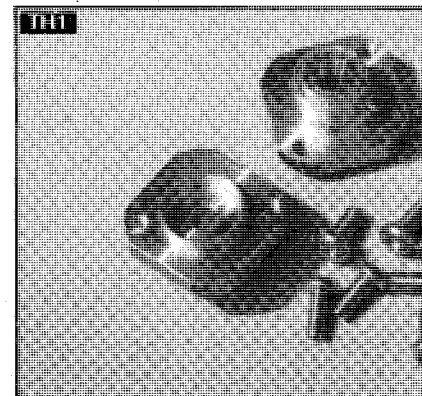

ZCA1 Yokomo T-Shirts  
 T-shirts available in small/-medium/large and X-large.  
 White T-shirt with Yokomo logs front and rear.

ZCA5 Yokomo Cap  
 Available in Yellow/Blue and Red colours.  
 ZCA7 Team Yokomo Banner  
 Trackside banner to give races that colourful element  
 ZCD1 Yokomo Decals  
 Two sheets small and large of the Yokomo name  
 ZCD2 Yokomo Logo Decals  
 Two sheets small and large  
 ZCD3 Team Yokomo Decals  
 Two sheets small and large

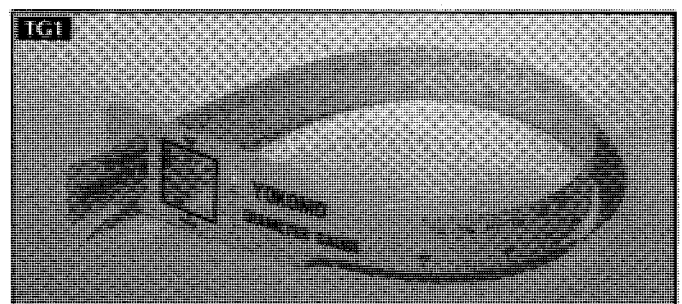

**TH-1 RC10 Wheel Adaptors**

Aluminium adaptors to fit Yokomo wheels to RC10

**TH-4 Tamiya 2WD Wheel Adaptors**

Aluminium adaptors to fit Yokomo wheels to Astute

**TH-5 Tamiya 4WD Wheel Adaptors**

Adaptors for egress.

**TH-6 Optima Wheel Adaptors**

Aluminium adaptors to fit Yokomo wheels to optima

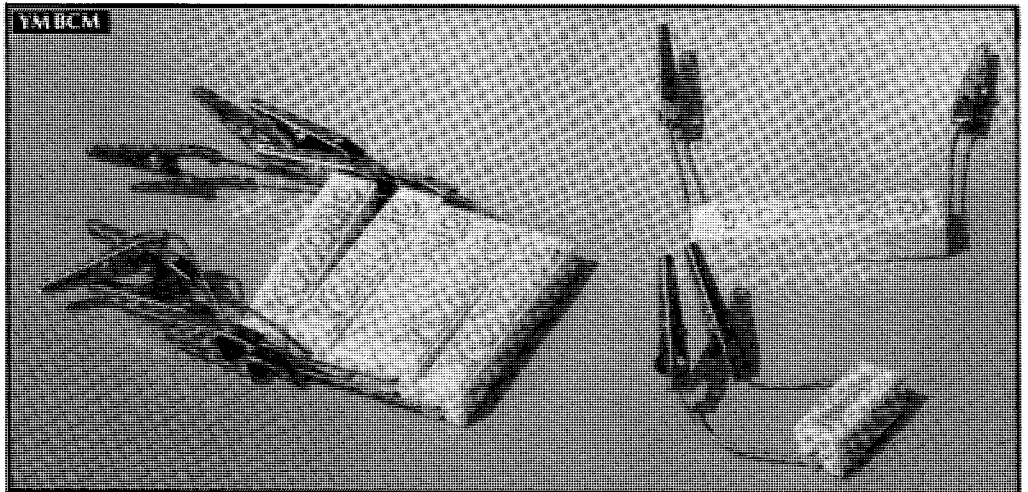

YC-8

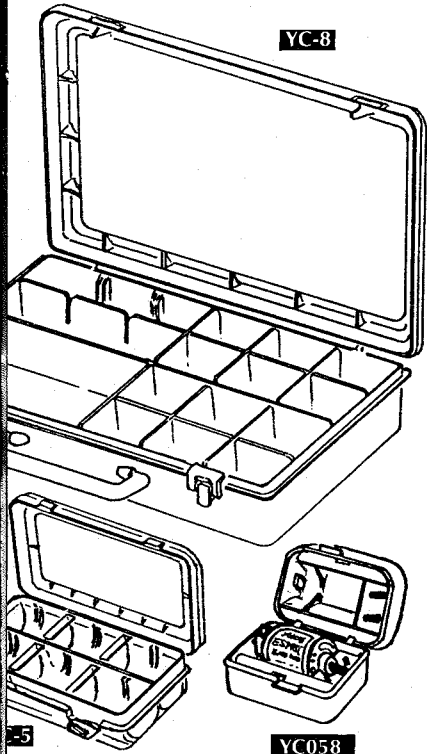

YC058

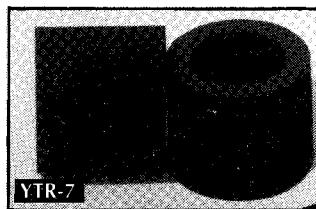
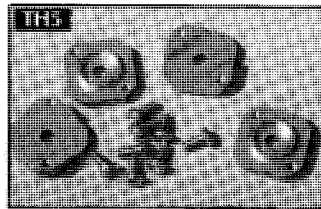

1/10 circuit racer. Superb wear rate and performance

**1/12 Circuit Tyres**

Y3360M 'L' Type Front Tyre (Medium)

Y3662 Miracle Front Tyre (Hard)

Y3620 Super Grip Rear Tyre

(Again excellent wear rate and grip)

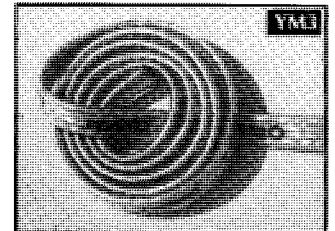
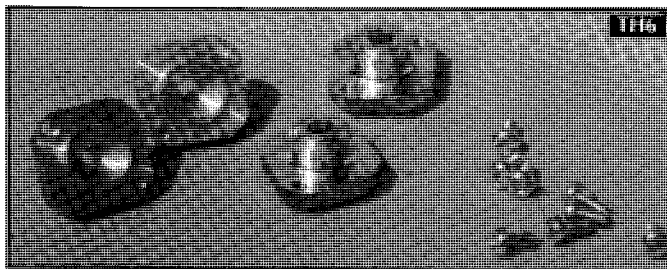

**YW3 Yokomo Battery Braid**

This braid is covered by a plastic covering for protection and features the Yokomo logo on the outside.

**YM058 Yokomo Motor Case**

Square case with compartment for brushes and pinions

YC1 Plastic Screw Boxx

YC2 Plastic Parts Small

YC5 Plastic Parts Box

Medium

YC6 Plastic Parts Box Large

YC8 Plastic Carrying Case with handle

(Above boxes come with removal partitions enabling you to make the compartment big/small for your actual needs)

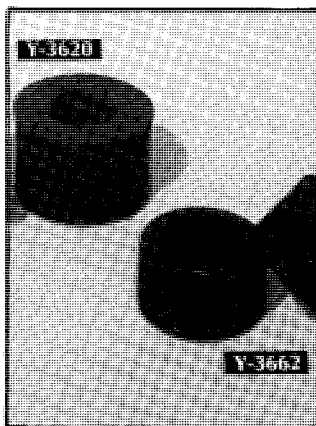

**Yokomo Esprit Motors**

YM14 Yokomo Esprit 'Torque' 17 Double

YM15 Yokomo Esprit 'RPM' 15 Double

YM19 Yokomo Esprit 'Oval' 18 Triple

(All motors come with Yokomo motor box capacitors, screws etc. Machine wound. Low cost motors - excellent performance).

**Yokomo 1/10 Circuit Tyres**

YTF1 Front Miracle Tyre (Hard)

YTF2M Front L-Tyre (Medium)

YTR7 Rear Super Grip Tyre (An absolute must for the serious

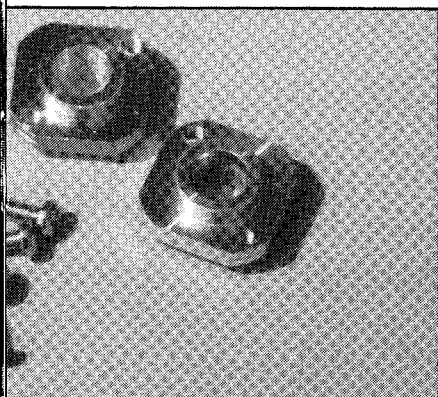

**TH-7 Cat Wheel Adaptors**

Aluminium adaptors to fit Yokomo Wheels to the cat

**TH-8 Ultima Wheel Adaptors**

Aluminium adaptors to fit Yokomo wheels to Ultima

**TG-1 Tyre Diameter Gauge**

in millimeters and inches to measure tyre diameters

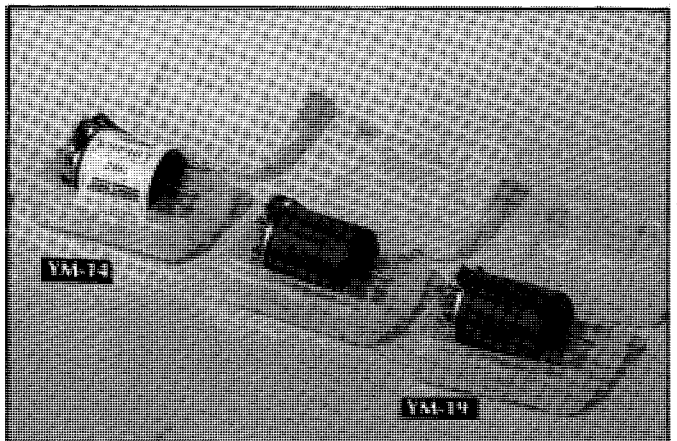
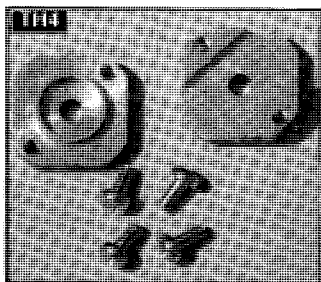

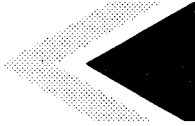

Team  
**NOVAK**

Team  
**NOVAK**

**NOVAK ELECTRONICS SPEED CONTROLLERS**

Novak Electronics have been, for many years, at the forefront of Speed Controller design. Their most recent innovation has been their range of TEMPFET® speed controls. By using temperature-sensing mosfets they have eliminated aggravating speed control failures due to overloads such as shorted motors, locked up transmissions or inadequate ventilation. The voltage drop has also been reduced to allow greater acceleration and longer running time.

Novak have also introduced four new controllers to their range giving you the chance to choose a speed control for every application.

**410-M1c and 410-MXc**

Team Novak introduces new, state-of-the-art high frequency technology for the 90s. The Novak Stealth Series electronic speed controls feature high frequency pulse width modulation, regenerative charging, smooth linear throttle response, and a dual-colour LED which together allow for

longer run times, decreased motor brush and commutator wear, greater speed and ease of adjustment. These features are made possible with Novak's in-house design of the NE1000M high-frequency digital CMOS integrated circuit.

Additional features include an adjustable current limiter, new ruggedized MEGAFET transistor for lowest ON - resistance, and thermal shut-off protection.

**What do these specifications mean?**

**PWM Frequency.**  
The frequency at which the speed control sends current pulses to the motor. A frequency of 2500Hz gives optimum efficiency without interfering with existing automatic lap counting systems.  
**On-Resistance.**  
The most important

**N1620**

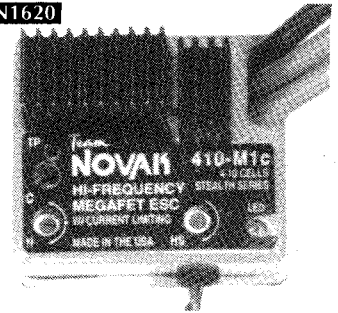

**What do these features mean?**

**Current Limiting (Active).**  
Lets the user set the maximum current (between 20 and 120A) through the motor. This sets the maximum motor torque which makes driving easier (especially off road) and increases running time.

**Reverse Voltage Protected (RVP).** The speed control electronics are protected if the battery pack is plugged in backwards.

**Power Plugs Installed.** The Associated Motor and Tamiya battery plugs allows an entry-level user to hook-up the speed controller without soldering.

**Motor Capacitors.** All Novak speed controls include the proper capacitors to suppress common mode and differential motor noise.

**Thermal Shut-off.** The speed control is protected with an internal temperature sensor which will shut off the drive circuitry if a dangerous rise in temperature is sensed due to overloads.

**Input Plug System.** The input harness can be changed from a Futaba J plug to either the Airtronics, KO, Kyosho or JR without soldering.

**Novak Speed Controllers**  
N1425 NESC-T4 (TEMPFET®-Econo)  
N1125 NESC-T1 (TEMPFET®-Pro)  
N1025 NESC-T1X (TEMPFET®-Eliminator)

Specifications	T4	T1	T1X	828-	410-M1c	410-MXc	610-
<b>Part No.</b>	N1425	N1125	N1024	N1520	N1620	N1720	N1820
<b>Input (Cells)</b>	4 to 10	4 to 10	to10	8-28	4 to 10	4 to 10	6 to 10
<b>Forward/Reverse</b>	F	F	F	F	F	F	F/R
<b>Case Width (in)</b>	1.57	1.57	1.62	1.62	1.58	1.58	1.58
<b>Case Length (in)</b>	1.33	1.33	1.80	1.80	1.39	1.78	1.78
<b>Case Height (in)</b>	0.62	0.62	0.62	0.62	0.62	0.62	0.62
<b>Weight (oz)</b>	1.74	1.58	2.46	2.51	1.76	2.29	2.21
<b>PWM Frequency (Hz)</b>	60	60	60	2500	2500	2500	2500
<b>On-Resistance (Ω)</b>	0.0045	0.0030	0.0015	0.0018	0.0030	0.0015	0.0090
<b>Current Efficiency</b>	>99%	>99%	>99%	>99%	>99%	>99%	>99%
<b>Rated Current (A)</b>	176	276	576	500	250	600	200F
<b>Braking Current (A)</b>	50	50	100	50	100	100	100
<b>Wire Size (GA)</b>	16	16	14	14	14	14	16
<b>Input Plug Length</b>	6	6	6	12	6	6	6

specification. The lower the On-Resistance, the more efficient the speed control, and the more power that is transmitted to the motor.

**Current Efficiency.** The percentage of current that is transmitted from the battery pack to the motor.

**Rated Current.** The current rating the drive transistors can withstand continuously at 25C transistor junction temperature.

**Braking Current.** The maximum continuous current at 25C transistor junction temperature that the speed control can handle when the brakes are fully applied.

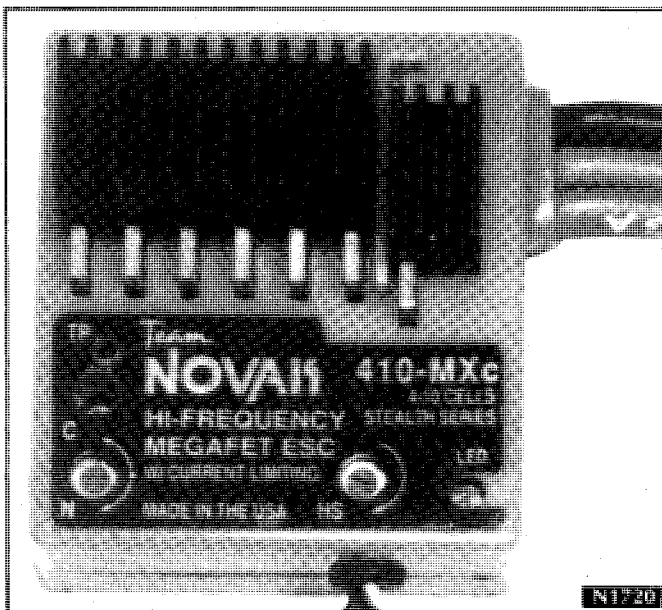

Features	T4	T1	T1X	828-	410-M1c	410-MXc	610-
<b>Current Limiting</b>					●	●	
<b>RVP</b>				●			
<b>Thermal Shutoff</b>	●	●	●				
<b>Power Plugs Installed</b>	●						
<b>Power Plugs Included</b>	N/A	●	●	●	●	●	N/A
<b>Heat Sinks Included</b>	●	●	●	●	●	●	●
<b>Motor Capacitors</b>	●	●	●	●	●	●	●
<b>LED for Settings</b>	●	●	●	●	●	●	●
<b>Input Plug System</b>	●	●	●	●	●	●	●
<b>Available in Fut. G.3</b>	●	●	●				



- N1520 NESC-828-HV (Hi-Voltage Megafet [aircraft]).
- N1620 NESC-410-Mlc (Megafet)
- N1720 NESC-410-MXc (Megafet)
- N1820 NESC-610-RV (Megafet)

**RECEIVERS**

Novak receivers are among the smallest available. By using surface mount electronics the NEW NER-2X is 45% smaller by volume than the NER-2S receiver which is small by any standards, and it weighs only 0.5oz. This makes them ideal for todays' limited space, complex 4WD off road or 1/12 cars.

Unlike most other manufacturers of two channel receivers, both the NER-2X and NER-2S work at a lower input voltage, stopping annoying glitches during acceleration. A battery output is also included for a separate battery pack or stutter stopper input.

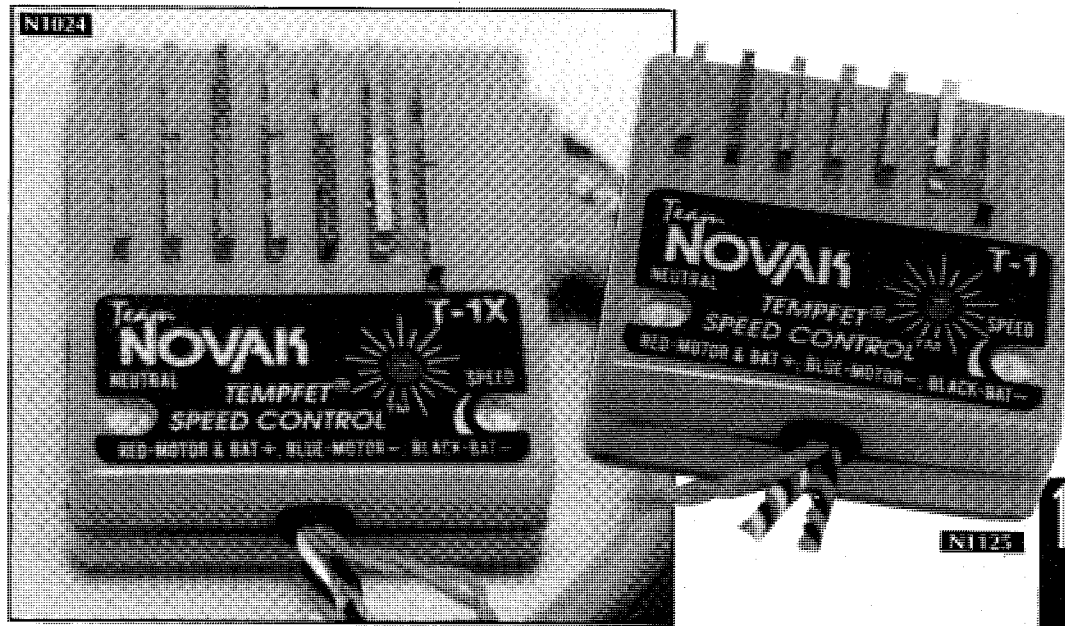

- N3227 NER-2S (Futaba J)
- N3327 NER-2S (KO Propo)
- N5430 Stutter Stopper (Futaba J)
- N5430 Stutter Stopper (KO Propo)
- N5450 JST (2X only).

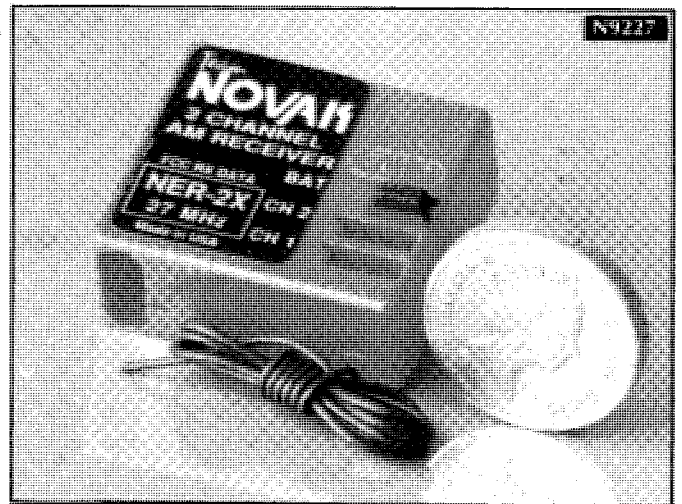

Specifications	NER-2X	NER-2S
Case Size (in)	1.10L	1.30L
	1.28W	1.46W
	0.53H	0.72H
Weight (oz)	0.50	0.75
Antenna Length (in)	18	18
Mixer Type	Double Balanced	
Output Channels	First two transmitter channels	
Plugs	A,G,J,K,P,JR	A,G,J,K
Freq. Bands (MNz)	27 and 75	
	Outside USA 29,35,40,72	
Crystal	Not Included	

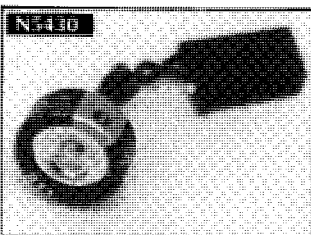

**What are Stutter Stoppers?**

When plugged into the battery terminal of the receiver, the Novak stutter stopper prevents the radio from stuttering with the use of todays' hotter modified motors.

Stutter stoppers are available for most radio types. The stutter stopper for the NER-2X comes with a JST plug. Size: 0.52" D x 0.24" H Weight: 0.10oz  
 N9227 NER-2X (Futaba J)  
 N9327 NER-2X (KO Propo)

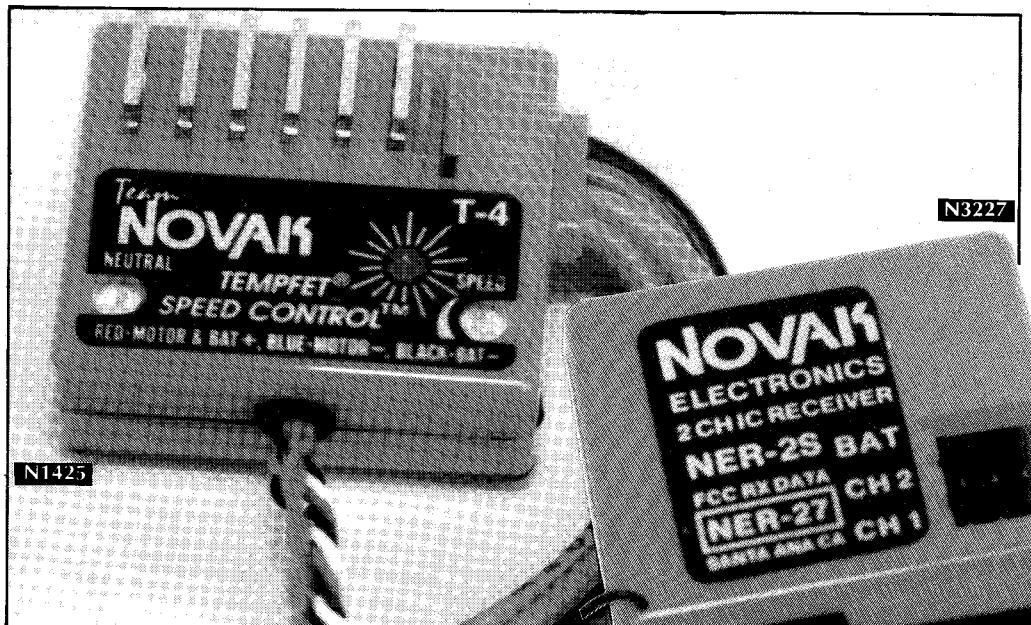

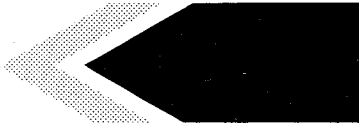

Specifications	Peak	Peak Plus
Case Size (in.)	7.10 L x 4.00 x 2.72H	
Weight (oz.)	8.30	11.20
Charge Capacity	4 to 7 cell batteries of 100 to 4000 MAH capacity from a 12 to 16 VDC power source	
Charge Rates (amps)	3.0 (adj. between 0-3.5) and 4.5	
Trickle Rate (amps)	0.18	0.18
Circuit Protection	Built-in automatic circuit breaker	
Heat Sink	Electrically isolated large heat sink	
Transistor Output	TEMPFET® transistor output for maximum efficiency	
Voltage Reading	Built-in voltmeter jacks on back. 3.5 digit LCD volt-ammeter.	
Case Material	Unbreakable orange and grey nylon,	

**Voltage Readings**

The Peak Plus Charger (NEC-3) has a built-in volt/ammeter (left) on the front plate and the Peak Charger (NEC-2) has built-in voltage-meter jacks on the back (right).

**Chargers**

Novak also manufacture a fine range of chargers, they include a temperature charger and two types of peak chargers. The NER-1 temperature charger is unlike many other chargers as it is a very compact size making it

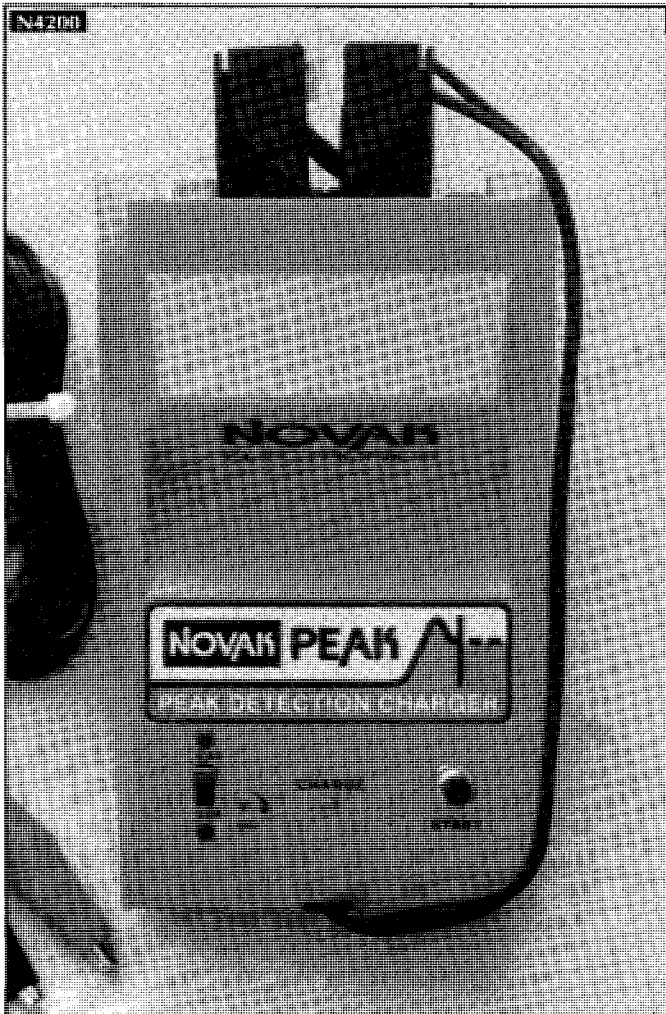
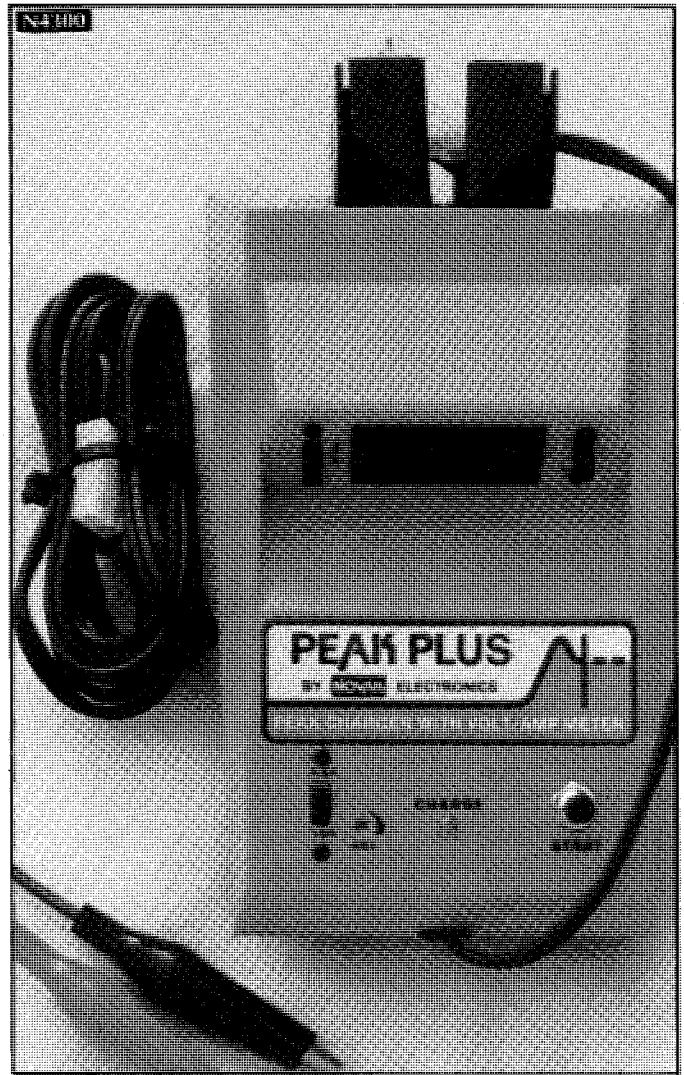

ideal for holding the battery's top charge on the line before the start of a race. It has adjustable charge and temperature cut off rate, constant current and will charge a 6 or 7 cell nicad pack from a 12V source. It also has the new TEMPFET'S® output transistors to protect it from reverse voltage and overloads.

All Novak chargers are protected against overloads and reverse voltage on both input or output.

**Peak and Peak Plus Chargers**

Designed to automatically charge 4 to 7 nickel cadmium batteries between 100 and 4000 MAH capacity from a 10 to 16 Volt DC power source. Both use the well-proven peak detection system to determine when the batteries are fully charged. Once the batteries are fully charged, the charger automatically switches to a 180mA trickle charge rate to equalise the charge within the battery pack,

holding the batteries in a fully charged state.

Both the Peak and Peak Plus Chargers have two selectable charge rates: 3.0 amps or 4.5 amps. The 3.0 amp rate can be adjusted from 0.35 amps to safely charge lower capacity batteries. An LED indicates the batteries are fast charging or trickle charging. Unlike many other chargers the Peak and Peak Plus Chargers use an exclusive one minute lock-out circuit to prevent aggravating false peaks.

Both chargers also have a built-in automatic circuit breaker and a TEMPFET® power transistor to protect the charger from any type of misuse (including shorts and reverse voltage on both the input and output). The circuit breaker automatically resets itself after the short or reverse voltage is corrected. New circuitry has also been added to both the Peak and Peak Plus Chargers to optimise the charging of the new Sanyo 1700 SCE batteries.

Team  
**NOVAK**



N7000

N7012

N7010



N7060

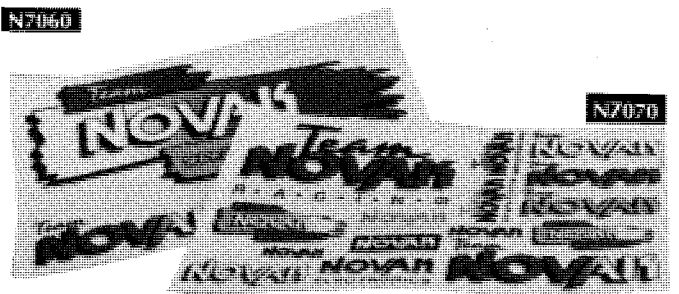

N7070

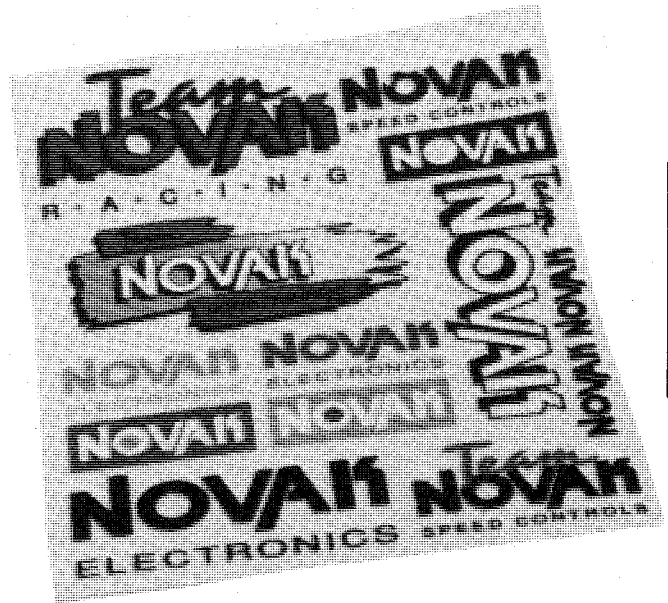

19



**FUSION SPEED**  
Shaping the future of graphite

**FUSION SPEED**

**Graphite Tub**

Wanna go faster with your RC10? Lose weight. Our new graphite tub chassis sheds over three ounces off the original, while gaining strength and rigidity.

**100% Graphite Fibres**

Most graphite chassis on the market today use fillers such as fibreglass or nylon – which cuts costs... and strength.

We use 100% graphite fibres. Pure graphite... with a bonding agent, which costs more, but when winning is on the line, there's no substitute for the best. Graphite gives the highest strength, lowest weight and best torsional rigidity. Best of all, should a massive load ever cause your chassis to flex, it's sure to return back to its original shape... thanks to graphite's unique "memory".

**Why a Tub?**

The original tub design, with high sidewalls, gives a twisting



strength that a flat-plate chassis design can't easily match.

Problem was, no one could figure out how to make a graphite tub at an affordable price. Until now. Our process is so unique there's a patent pending on the concept.

**Easy Installation**

Made to factory specs of the original RC10 aluminium tub, your tranny, suspension and steering system will bolt right to

the Fusion Speed model.

**Matching Guarantee**

This chassis is so strong that it carries an equally strong guarantee: If you break an unmodified Fusion Speed chassis, we'll replace it free of charge.

**Available to More than Pro's**

This high-tech race chassis is

available to everyone, not just the pro's. And offering top value the Fusion Speed graphite chassis gives you the edge in racing.

Watch out for more fusion speed products!

## PROLINE PRODUCTS "OFF ROAD" TYRES

RED (Race Engineered Design)  
(All RED tyres are for serious competition only and are made from lightweight, natural rubber to give maximum performance).

**PL7010**

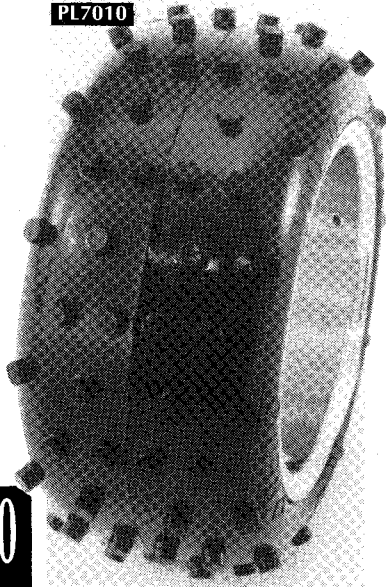

### Pro-10

Application: Loose to medium dirt or clay conditions  
Design: Flat low knobby. Fits 2.0" wheel.

Part No. PL7010

### PRO-15

Application: Medium to hard-pack conditions  
Design: Multi-Ribbed Fits 2.0" wheel.

Part No. PL7015

### Pro-20

Application: Medium to hard pack conditions. Short grass.  
Design: Multi-Sized Spikes, large going to small. Fits 2.0" wheel.

Part No. PL 7020

### PRO-30

Application: Medium to hard pack conditions, short grass, loose conditions.

Design: Mini Spikes. Fits 2.0" wheel.

Part No. PL7030

**PL7015**



**PL7020**



**PL7030**



**PL1003**

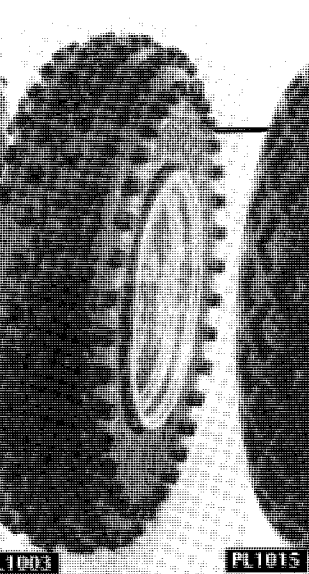

**PL1015**



### Side Bite DC-2

Application: Loose to damp conditions

Design: Large Multi Spikes. Fits 1.5" wheel.

Part No. PL1002

### Knobby DC-3

Application: Tight turning on almost all surfaces.

Design: Small Mini Spikes, Multi-Design, soft compound.

Fits 1.5" wheel.

Part No. PL1003

### Knobby (4)

Application: Same as 1003

Design: Same as 1003 but in hard compound

Part No. PL1004

### Road Runner DC-9

Application: Medium pack clay/dirt.

Design: Large Spikes, long wearing compound. Fits 1.5" wheel.

Part No. PL1009

### Champion

Application: Hard pack dirt conditions

Design: Medium/Large Spikes. Fits 1.5" to 1.7" wheel.

Part No. PL1010

### Champion DC-11

Application: Same as 1010

Design: Same as 1010 but softer compound

Part No. PL1011

### Champion DC-12

Application: Same as 1010

Design: Same as 1010 but fits 1.6" wheel.

Part No. PL1012

### Champion DC-13

Application: Same as 1012

Design: Same as 1012 but softer compound

Part No. PL1013

### Sidewinder AT-14

Application: All terrain

Design: V-Pattern. Fits 1.5" - 1.7" wheel.

Part NO. PL1014

### Diamond AT-145

Application: All terrain

Design: Diamond Pattern. Fits

1.5" wheel.

Part No. PL1015

### Knobby DC-18

Application:

Medium to

hard dirt,

dry short

grass.

Design:

Small

Multi-

Pattern

Spikes.

Fits 1.9"

wheel

Part No.

PL1018

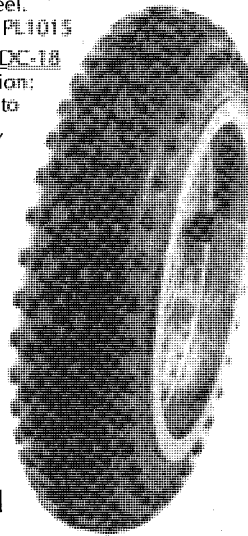

**PL1018**

### Octi-Grab AT20

Application: All terrain, favours smooth flat surfaces.

Design: Rear Octi-Grab. Fits 1.5" wheel.

Part No. PL1020

### Diamond DC-21

Application: Hard pack fast tracks.

Design: Diamond pattern. Fits 1.9" wheels.

Part No. PL1021

### Knobby DC-23

Application: For tight turning on soft dirt/grass

Design: Small Knobbles. Fits 2.1" wheel.

Part No. PL1023

### Diamond AT-24

Application: Tall and narrow for hardpacked flat tracks, asphalt, etc.

Design: Diamond Pattern. Fits 2.1" wheel.

Part No. PL1024

### Champion DC-25

Application: 4WD Specialist, soft, medium dirt tracks or grass.

Use front or rear.

Design: Random, Medium

Spike. Fits 2.0" - 2.1" wheel.

Part NO. PL1025

### Roost Monger DC-26

Application: Loose dirt, worn, short grass.

Design: Paddle/Knobby combination. Fits 2.0" - 2.1" wheel.

Part No. PL1026

### Mud Wrestler DC-27

Application: Damp, muddy conditions. Doesn't clog up.

Design: Wide Spaced Medium Spike. Fits 2.0" - 2.1" wheel.

Part No. PL1027

### Viper DC-28

Application: Fast soft tracks.

Design: V Pattern Tread. Fits 2.0" - 2.1" wheel.

Part No. PL1028

### Apache AT-29

Application: Medium to hard surface tracks with fast turns, asphalt.

Design: Low profile, V-Pattern, extra width for better handling. Fits 2.0"-2.1" wheel.

Part No. PL1029



**PL1030**

### Cherokee AT-30

Application: Multiple turn asphalt or hard dirt tracks.

Design: Small waffle, extra width. Fits 2.0" - 2.1" wheel.

Part No. PL1030

### Commanche AT-31

Application: All hard surfaces, asphalt/dirt.

Design: Large waffle, extra



PL1016

### Sidewinder AT-33

Application: All terrain  
Design: V-Pattern. Fits 1.7" wheel.

Part No. PL1033

Dirt Flirt DC-34

Application: Loose dirt or short grass.

Design: Low Profile, Pin Spikes. Fits 2.1" wheel.

Part No. PL1034

Terra Tamer

DC-35

Application:

Loose to medium dirt or grass.

Design: Medium pin spikes.

Fits 1.9" wheel.

Part No.

PL1035

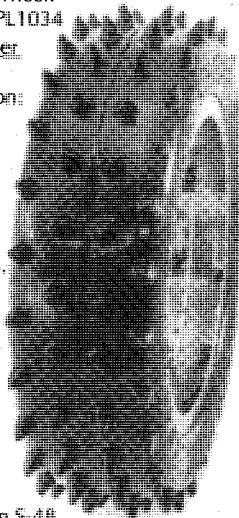

PL1035

### Sand Sling S-48

Application: Loose sand and snow conditions.

Design: Paddle. Fits 2.0" wheel.  
Part No. PL1048

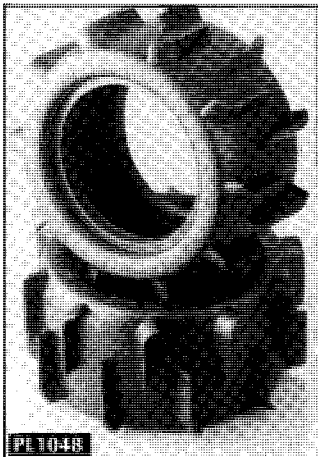

PL1048

### Centre Line DC-49

Application: Soft to medium pack tracks.

Design: Centre Rib with Outside Spikes. Fits 2.1" wheel.



PL1019

### Tyre Size Guide

1.5" Wheel - Grasshopper, Hornet, PL2503, PL2506.  
1.7" Wheel - Falcon, Striker (Rear), RC10 stock (Rear)  
1.9" Wheel - RC10 stock (Front), Falcon, Striker.  
2.0"-2.1" Wheel - Cat, Yokomo, TQRC10, JR-X2, Cougar, MID4, Lazer, Egress, Astute, Boomerang, etc.

### WHEELS

PRO-LINE'S most popular wheels have been improved by strengthening the nylon compound, while retaining their popular lightweight feature. These stronger nylon wheels are designed for high impact resiliency and fracture resistance in race and heavy use conditions.

In addition, these same wheels are offered in chrome. PRO-LINE's chrome plated process is known as the best in the industry. Stringent standards have been set in order to produce these highly chip resistant, glossy wheels.

PL2503 Front Chrome with Assembly Hardware. 1.5" Diameter.

PL2506 Rear Chrome with Assembly Hardware. 1.5" Diameter.

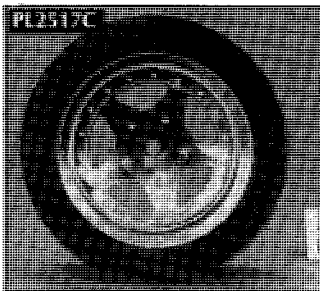

PL2517 Rear Dyable fits late Tamiya. 2.0" Diameter.

PL2517C Rear Chrome fits late Tamiya. 2.0" Diameter.

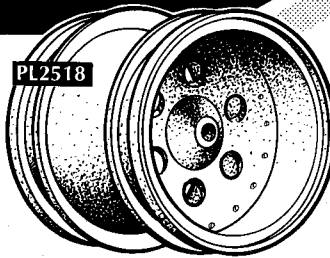

PL2518

PL2518 Rear Dyable 2WD & 4WD fits late Kyosho. 2.0" Diameter.

PL2518C Rear Chrome 2WD & 4WD fits late Kyosho. 2.0" Diameter.

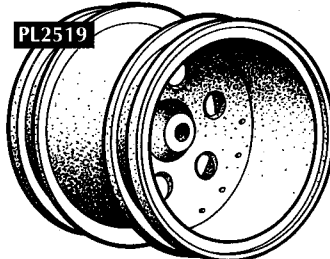

PL2519

PL2519 Rear Dyable fits RC10 & early Kyosho. 2.0" Diameter.

PL2519C Rear Chrome fits RC10 and early Kyosho. 2.0" Diameter.



PL2517

PL2520 Front or Rear Dyable 4WD fits Yokomo. 2.0" Diameter.

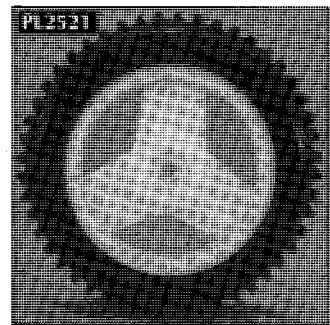

PL2521

PL2521 Rear Dyable 4WD fits Tamiya. 2.0" Diameter.

PL2522 Front Dyable fits Tamiya. 2.1" Diameter.

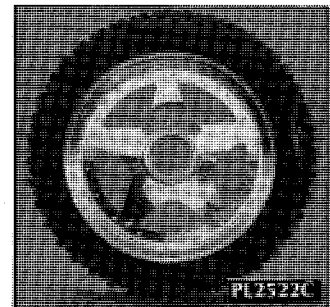

PL2522C

PL2522C Front Chrome fits Tamiya. 2.1" Diameter.

PL2523C Front Chrome fits RC10 & Kyosho. 2.1" Diameter.

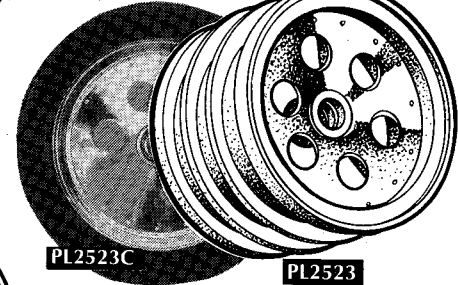

PL2523C

PL2523

PL2550 Front Narrow Dyable Racing Wheel fits Yokomo. 2.0" Diameter.

PL2531 Front Dyable JR-X2 Replacement wheel. 2.1" Diameter.

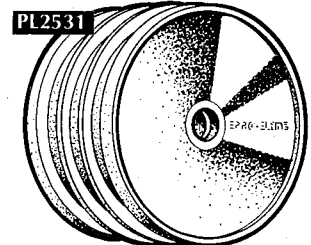

PL2531

PL2532 Rear Dyable JR-X2 Replacement Wheel. 2.0" Diameter.

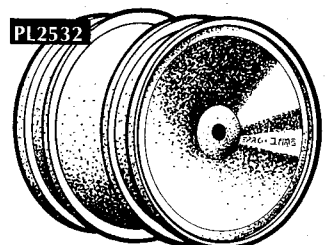

PL2532

PL2547 Front Chrome JR-X2 Replacement Wheel. 2.1" Diameter.

PL2548 Rear Chrome JR-X2 Replacement Wheel. 2.0" Diameter.

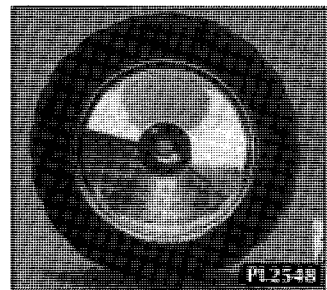

PL2548

### Cone Deep Dish Racing Wheel with Dirt Shield

The new PRO-LINE Cone Dish Racing Wheels include a Dirt Shield, which should more than satisfy numerous requests from dealers and enthusiasts alike. The enthusiasts, mostly racers,

needed a wheel that wouldn't pick up dirt. This build up adds unwanted weight to the car as well as restricting turning and speed. The Cone Dish Racing Wheel is constructed of a very strong, lightweight nylon compound. Its unique cone design combined with the rear mounted dirt shield retards dirt and sand in all off-road racing applications.



PL1053

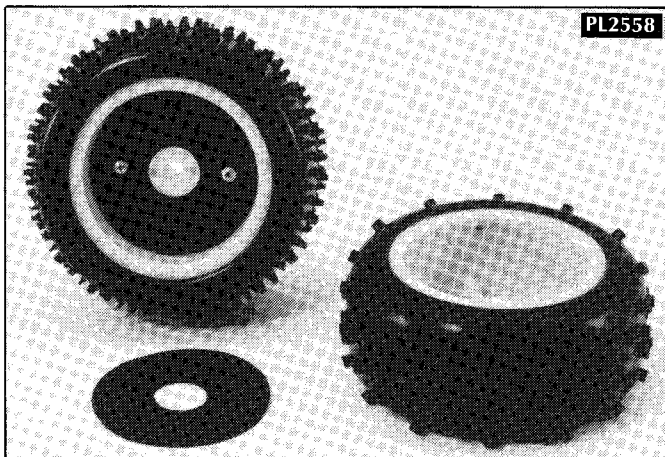

Design: Low Profile, small waffle. Fits 1.5" wheel.  
Part No. PL1016  
Apache AT-29  
See Off Road Section for details. Part No. PL1029  
Cherokee AT-30  
See Off Road Section for details. Part No. PL1030  
Comanche AT-31  
See Off Road Section for details. Part No. PL1031  
Waffle AC-32  
Application: Heavy use race conditions on asphalt or concrete.

Design: Low Profile waffle. Fits 1.7" wheel.  
Part No. PL1032  
Sprinter Slick AC-40  
Application: Large slick surface for extra traction on asphalt.  
Design: Slick. Fits 2.0" wheel.  
Part No. PL1040  
Striker II AC-51  
Application: This extra flat, low profile tyre is the ultimate for traction in wet and dry giving superb realism.  
Details: Indy Profile. 1.7" wide flat track. Fits 2.0" wheel.  
Part No. PL1051  
Striker III AC-53  
Application: High speed hard surface racing.  
Design: Indy Profile, wide flat. Fits 2.0" wheel.  
Part No. PL1053

- PL2549 Front Narrow Dyable Cone Dish Racing Wheel with Dirt Sheidl. Fits Kyosho 4WD car. 2.0" Diameter.
- PL2557 Front Dyable Cone Dish Racing Wheel with Dirt Sheidl. Fits RC10 & Kyosho 2WD. 2.0" Diameter.
- PL2558 Rear Dyable Cone Dish Racing Wheel with Dirt Shield. Fits RC10. 2.0" Diameter.
- PL2559 Front Dyable Cone Dish Racing Wheel with Dirt Shield. 2.0" Diameter.
- PL2560 Rear Dyable Cone Dish Racing Wheel with Dirt Shield. Fits JR-X2. 2.0" Diameter.
- PL2561 Rear Dyable Cone Dish Racing Wheel with Dirt Shield. Fits Kyosho. 2.0 Diameter.

**BODIES**

- PL3001 Class One Racing Buggy, single seater
- PL3002 Baja Bug Clear Lexan, fits RC10/Ultima etc.
- PL3009 Ultimate Butterfly Baja Bug, fits Ultima/RC10, clear Lexan
- PL3010 Butterfly single seater, clear Lexan, Ultima
- PL3004 Wing - small clear Lexan
- PL300 5 Wing - medium clear Lexan
- PL3006 Wing - large clear Lexan

**ON ROAD PRODUCTS Tyres**

Waffle AC-16  
Application: Tight asphalt and

**ACCESSORIES**

- PL4504 Bumper dyable fits RC10 and PRO-10 cars
- PL4059 Nerf Bar, fits RC10
- PL4510 Bumper, dyable fits Grasshopper and Hornet
- PL4512 Bumper, dyable fits Blackfoot.
- PL5311 Wheel Knock off, dyable (4 pcs)
- PL5312 Wheel Knock off, chrome (4 pcs)

PL 3002

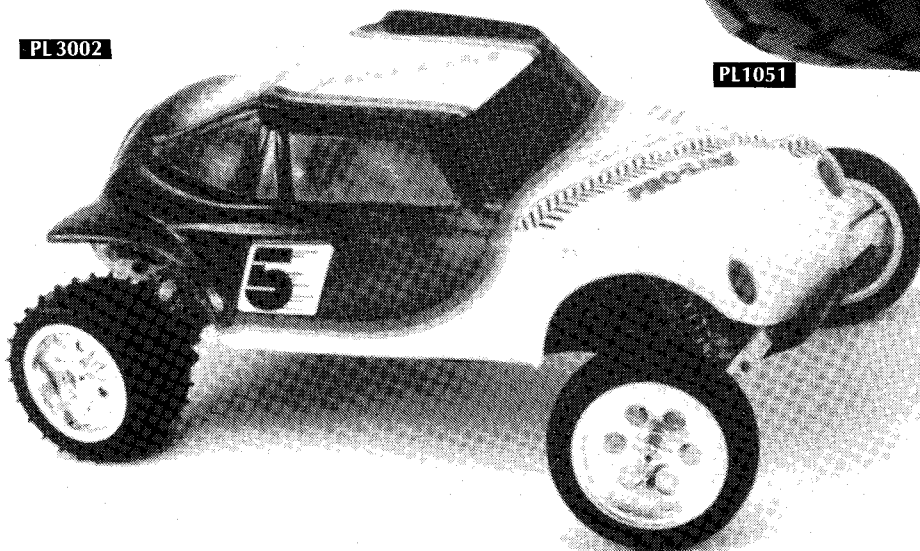

PL1051

## WHEELS AND TYRES ON ROAD SPONGE TYRES

### Features:

- ★ Advanced Racing Compound for longer runtime and better acceleration.
- ★ Lifetime Guarantee on the wheel for the life of the tyre.
- ★ Soft, medium and firm mixtures that maximise traction in varying race conditions.
- ★ Each individual tyre is mounted, trued to .002 total runout and balanced +/- 1 gram.

Fit 2.0" wheels

- FRONT- without wheels  
 PL1055 Soft (Yellow)  
 PL1056 Medium (Green)  
 PL1057 Firm (Blue)  
 REAR - without wheels  
 PL1058 Soft (Yellow)  
 PL1059 Medium (Green)  
 PL1060 Firm (Blue)

PL1040

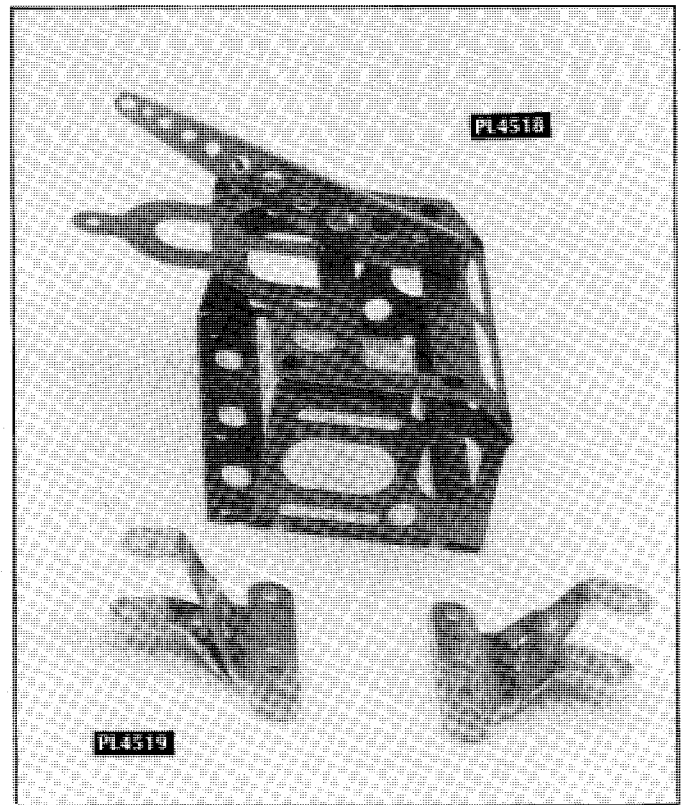

### On-Road Wheels

- PL2564 FRONT On-Road Dyable wheel. 2.0" Diameter.  
 PL2564C FRONT Chrome.  
 PL2565 REAR On-Road Dyable wheel. 2.0" Diameter.  
 PL2565C REAR Chrome.

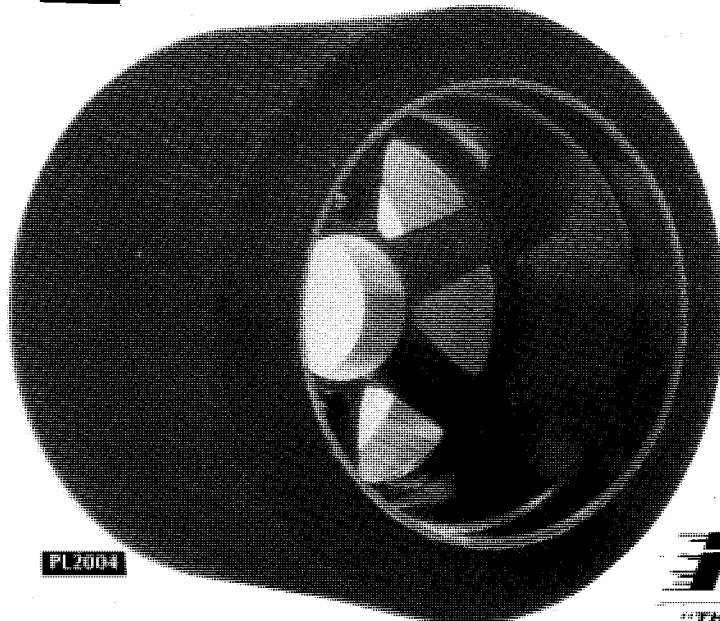
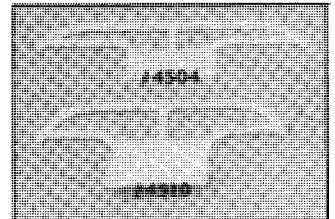

PL2003

### Mounted Sponge Tyres

- FRONT - Mounted and trued on 2.0" Racing Wheels (Dyable) Wheels (Dyable)  
 PL2001 Soft (Yellow)  
 PL2002 Medium (Green)

PL2003 Firm (Blue)

- REAR - Mounted and trued on 2.0" Racing Wheels (Dyable) Wheels (Dyable)  
 PL2004 Soft (Yellow)  
 PL2005 Medium (Green)  
 PL2006 Firm (Blue)

PL3017

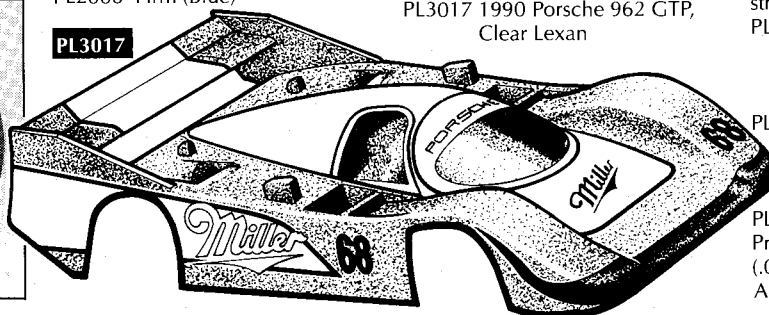
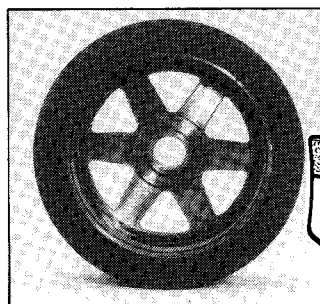

# PRO-LINE

"The Best Parts of Winning"

### Bodies

- PL3012 Nascar T-Bird, Clear Lexan  
 PL3016 Pontiac Nascar, Clear Lexan  
 PL3017 1990 Porsche 962 GTP, Clear Lexan

### On Road Accessories

- PL4504 Bumper, dyable, fits RC10/PRO-10  
 PL4518 Titanium Rear Pod for Associated RC10L (lighter and stronger)  
 PL4519 Titanium Front Suspension Arms for associated 10L, 12L and other On-Road cars (lighter and stronger)  
 PL4520 Soft Front End Progressive Spring Set. (.016-2pcs) fits Associated front end.  
 PL4521 Medium Front End Progressive Spring Set. (.020-2pcs) fits Associated Front End.  
 PL4522 Firm Front End Progressive Spring Set. (.024-2pcs) fits Associated front end.



PL1045

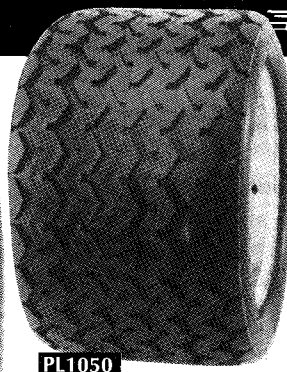
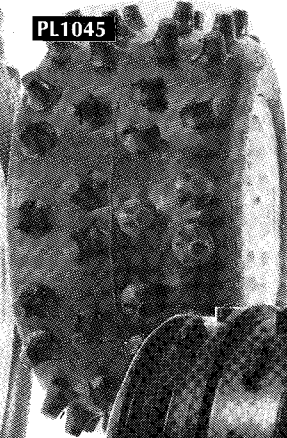

PL1050

### Monster Truck Red Tyres

Pro-40  
Front or Rear Mini Pin with Centred Crossbars. Part No. PL7040  
Pro-45  
Front Multi Rib with Staggered Bars. Part No. PL7045  
Pro-50  
Front or Rear Mini Pin with Staggered Cross Bars. Part No. PL7050

PL1043

### Monster Truck Products

**Masher AT-41 Tyres**  
Application: Mud and Truck pulling  
Design: Large V-Pattern. Fits 2.2" wheel.  
Part No. PL1041  
**Race Paw DC-42**  
Application: Loose to medium pack, grass.  
Design: 1.2 Step Block. Fits 2.2"

wheel.  
Part No. PL1042  
**Dirt Paw DC-43**  
Application: Loose to medium pack, grass.  
Design: 18-Step Block. Fits 2.2" wheel.  
Part No. PL1043  
**Trac-TA-Gator AT-45**  
Application: All dirt surfaces, grass.  
Design: Large race spikes. Fits 2.2" wheel.  
Part No. PL1045

PL7045

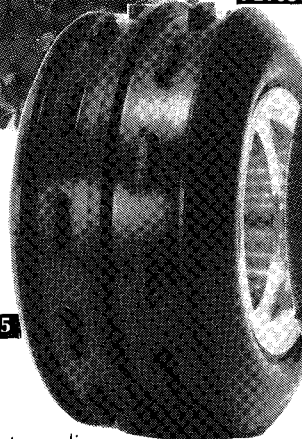

PL7040

PL7050

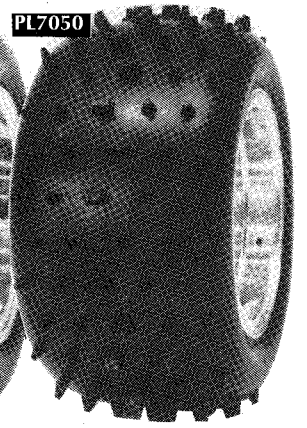

**Road Paw AC-46**  
Application: Asphalt, clay, carpet and concrete.  
Design: High Profile Flat track tread. Fits 2.2" wheel.  
Part No. PL1046.

**Speed Paw DC-47**  
Application: Medium to hard pack surfaces, short grass.  
Design: Mini Pin Race Spikes. Fits 2.2" wheel.  
Part No. 1047

### Monster Truck Wheels Solid Deep Dish

PL2526 Front Dyable fits Blackfoot, Monster Beetle and RC10 Monster Truck Conversion. RC10 requires axle No. 5316; 2.2" Diameter.

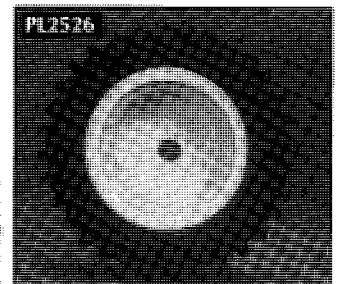

PL2527 Rear Dyable fits Blackfoot and Monster Beetle. 2.2" Diameter.

PL2528 Front Chrome fits Blackfoot, Monster Beetle and RC10 Monster Truck Conversion. 2.2" Diameter.

PL2529 Rear Chrome fits Blackfoot and Monster Beetle. 2.2" Diameter.

PL2533 Rear Dyable fits RC10 Monster Truck Conversion. No adaptors needed. 2.2" Diameter.

PL2534 Rear Chrome fits RC10 Monster Truck Conversion. No adaptors needed. 2.2" Diameter.

### Deep Dish 10-Hole

PL2542 Front Dyable fits JR-X2

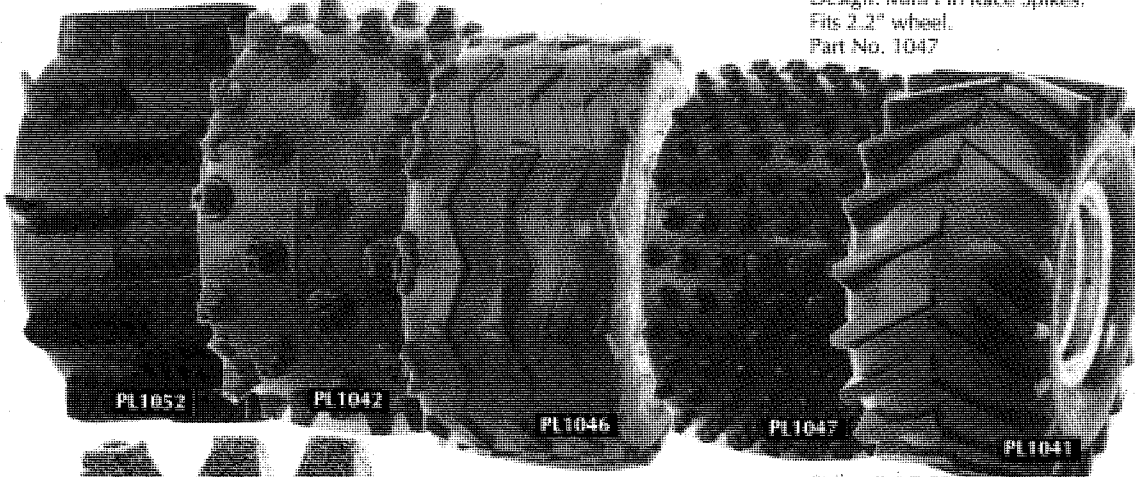

PL1052

PL1042

PL1046

PL1047

PL1041

**Striker II AC-50**  
Application: On-Road and oval. Race proven on concrete and asphalt.  
Design: Realistic Low Profile. Fits 2.2" wheel.  
Part No. PL1050  
**Sand Paw S-52**  
Application: Sand and snow.  
Design: Paddle. Fits 2.2" wheel.  
Part No. PL1052  
**Front Runner AT-54**  
Application: All surfaces  
Design: Multiple Rib. Fits 2.2" wheel.  
Part No. PL1054

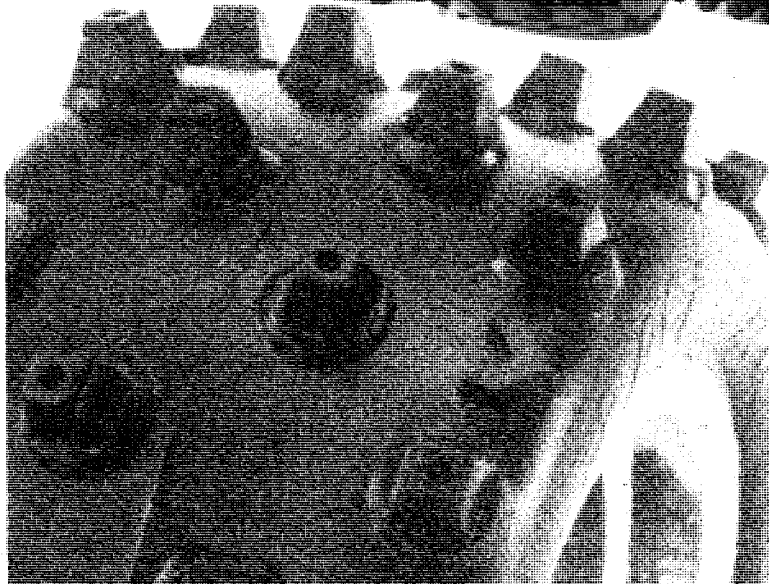



Monster Truck Conversion. Requires axle No. 5319. 2.2" Diameter.

- PL2543 Rear Dyable fits JR-XT and JR-X2 Monster Truck Conversion. No adaptors needed. 2.2" Diameter.
- PL2544 Front Chrome fits JR-X2 Monster Truck Conversion. Requires axle No. 5319. 2.2" Diameter.
- PL2545 Rear Chrome fits JR-X2 Monster Truck Conversion. No adaptors needed. 2.2" Diameter.
- PL2563 Front Direct Fit. Fits JR-X2. 2.2" Diameter. Five Blade Directional (Direct Fit)
- PL2551 Front Dyable fits RC10 and Ultima Monster Truck Conversions. 2.2" Diameter.
- PL2551Y Front Neon Yellow. 2.2" Diameter.
- PL2551C Front Chrome. 2.2" Diameter.

## COMPLETE MONSTER TRUCK CONVERSION KIT

A complete Kit that comes loaded with all of the conversion accessories to convert your RC10, JR-X2 or Kyosho Ultima into a PRO-LINE Monster Truck. The kit incdes PRO-LINE competition knobby tyres, direct fit nylon dyable wheels, extended axles to improve performance and durability, clear lexan Racing truck body, extra sturdy front and rear truck body mount/posts, nylon wheel bearings, detailed assembly instructions and a FREE Neon Monster Truck deal.

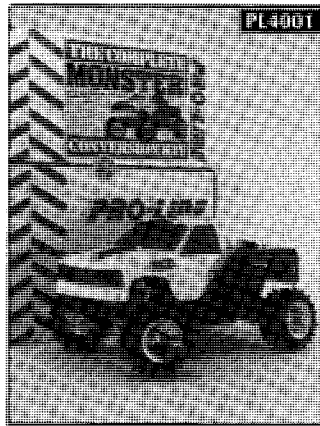

- PL4001 RC10 (includes Chevy Stadium Body)
- PL4002 JR-X2 (includes Toyota Extra Cab Body)
- PL4004 Kyosho Ultima (includes Ford Ranger Body)

## Basic Monster Truck Conversion Kit

The basic kit allows you to individualise your truck conversion with any PRO-LINE truck body and PRO-LINE Competition Tyres. The kit includes direct fit front and rear

dyable wheels, sturdy body brackets/posts, detailed assembly instructions. The kit also includes a FREE Neon Monster Truck decal.

- PL4005 RC10.
- PL4006 JR-X2
- PL4008 Kyosho Ultima/Raider

## Accessories

- PL4509 RC10
- PL4512 Bumper, Dyable, fits Blackfoot.
- PL4513 Bumper, Chrome fits Blackfoot.
- PL4515 Universal Body Bracket 65 degree.
- PL4516 Universal Body Bracket. 90 degree.
- PL4517 Shadow and Wing Detailing Kit.
- PL5301 Screws and Nuts. slotted Pan-Head 2-56 x 3/8, 20 pcs.
- PL5312 Wheel Knock Off, Chrome (4 pcs).
- PL5315 Rear Metal Lug Nut for the RC10 Monster Truck Conversion
- PL5316 Front Axles with nuts for the RC10 Monster Truck Conversion (2 pcs).
- PL5317 Wheel Knock Off, Dyable, for the RC10 Monster Truck Conversion (4 pcs).
- PL5318 Wheel Knock Off, Chrome, for the RC10 Monster Truck Conversion (4 pcs).
- PL5319 Front Extended Axles with nut for the JR-X2 Monster Truck Conversion (2 pcs).
- PL5321 Front Axles for Ultima Monster Truck Conversion (2 pcs).
- PL6140 Adjustable Body Mount Post Kit.

## Bodies

- PL 3003 Nissan Hardbody, clear lexan.

## Miscellaneous Accessories

- PL5301 Screws and Nuts – Slotted Pan Head. 2-56 x 3/8. (20 pcs).
- PL4322 Large Servo Saver.
- PL5323 No Leak Top Shock Seals for RC10 and JR-X2 (4 pcs).
- PL6005 3 Pin Connector Set
- PL6010 2 Pin Connector Set
- PL6015 1 Amp Fuses (Pkg of 6).
- PL6020 6 Amp Fuses (pkg of 6).
- PL6025 Drive Pin Kit.
- PL6030 Motor, Capacitor Kit.
- PL6035 Threaded Rod 4-40 x 6" (4 pcs).
- PL6040 Velco 1/2" x 6"
- PL6045 Tie Wraps – Assorted (pkg of 20).
- PL6050 Body Clips (pkg of 20).
- PL6055 Servo Saver
- PL6060 Ball Links 2 – 56 (pcs. and hardware).
- PL6065 Ball Links 4 – 40 (4pcs. and hardware).
- PL6070 Differential Rebuild Kit.
- PL6075 Motor Brushes (2 pcs).
- PL6080 Servo Tape – 3/4" x 36"
- PL6085 Gear and Assembly Lube
- PL6090 Metric Hardware – Assorted ( 28 pcs).
- PL6095 U.S. Hardware – Assorted (34 pcs).
- PL6100 Heat Shrink Tubing – 1/8" and 3/16" (8 pcs).
- PL6115 Foam Motor Cover.
- PL6120 2 Pin Connector with Wire.
- PL6125 Battery Conditioning Kit
- PL6130 Bearing Oiler – 1/2 oz.
- PL6135 Silicone Wire – Red (2.5ft) and Black (2.5ft)
- PL5315 Pinpoint Lubricator Syringe
- PL 6085 Gear and Assembly Lube
- PL6130 Pro Bearing Oiler, 1/2oz

## APPAREL AND DECALS

- PL9901 PRO-LINE World Champion Racing T-Shirt (S, M, L, X-L. XX-L available).
- PL9906 PRO-LINE Racing Hat – Blue Corduroy (One Size Fits All)
- PL9908 PRO-LINE Fluorescent Yellow "Play Dirty" T-Shirt (S,M, L, X-L. XX-L available).
- PL9909 PRO-LINE Monster Truck T-Shirt (S, M, L, X-L. XX-L available).
- PL9913 RED Racing Team Decal.
- PL9914 Pro-Line Neon Monster Truck Racing Decal.
- PL9915 PRO-LINE Racing Team Decal. Available in Black, White, Neon Magenta and Neon Blue.

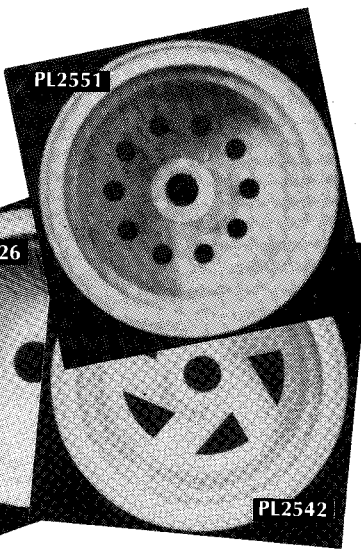

- PL2552 Rear Dyable fits Ultima Monster Truck Conversion. 2.2" Diameter.
- PL2552C Rear Chrome. 2.2" Diameter.
- PL2553 Rear Dyable fits RC10 Monster Truck Conversion. No adaptors. 2.2" Diameter.
- PL2553Y Rear Neon Yellow. 2.2" Diameter.
- PL2553C Rear Chrome. 2.2" Diameter.
- PL2562 Front Dyable. Fits RC10 and Kyosho Monster Truck Conversions. 2.2" Diameter.

PL3013

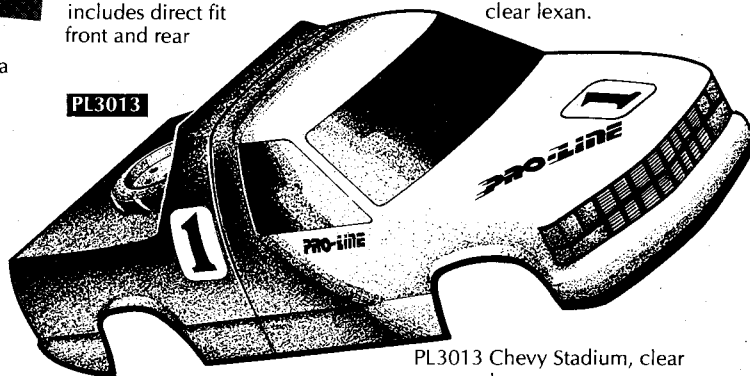

- PL3013 Chevy Stadium, clear lexan.
- PL3014 Chevy Stadium Dually, clear lexan.
- PL3015 Toyota Extra Cab, clear lexan.
- PL3018 Ford Ranger, clear lexan.



*Andy's*

**Andy's R/C Products  
1/10 Scale. 0.30 Lexan  
Bodies.**

- AP3020 Renegade "Off Road"
- AP3021 Renegade Longnose "Off Road"
- AP3022 Heathen "Off Road" TQ10, Graphite RC10
- AP3023 Half-Breed "Off Road" JRX-2
- AP3024 Renegade Stage II "Off Road"
- AP2025 Elan "Off Road" with belly pan for Mid

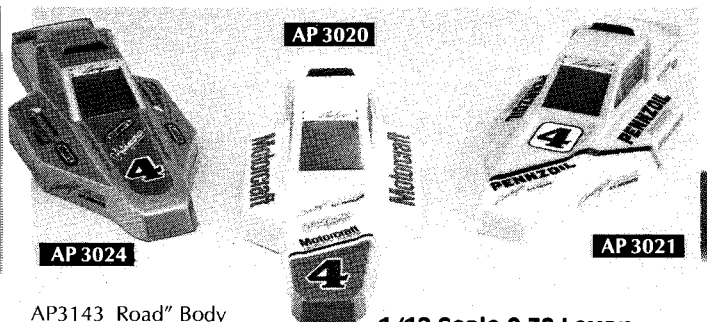
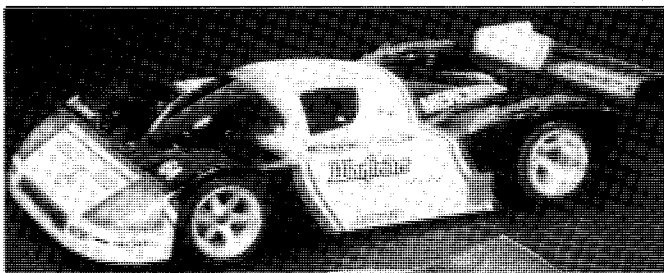
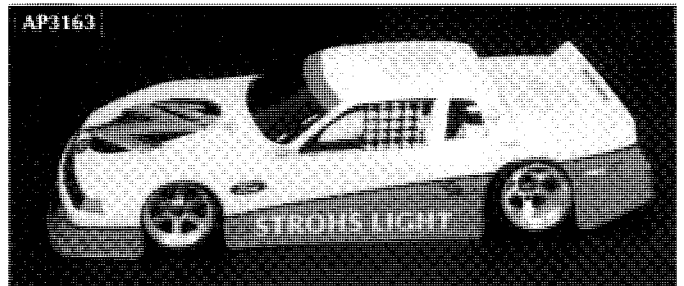
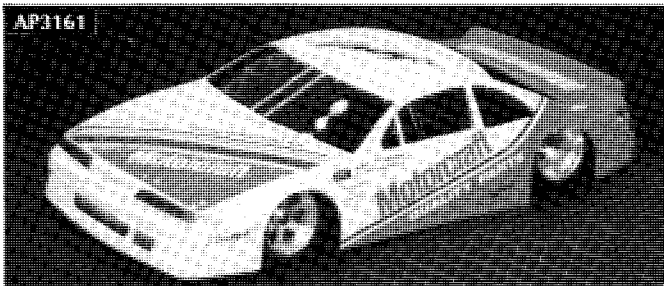

26

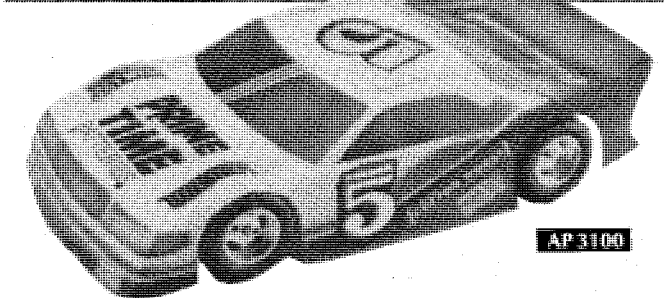

- AP3143 Road" Body '89 Mercedes GTP
- AP3144 Mercury "Merkur"XR4Ti
- AP3145 Nissan GTP
- AP3146 300 ZX (GTO)
- AP3147 Ferrari F-40 (GTO)
- AP3160 '89 Pontiac Grand Prix - Nascar
- AP3161 '89 Ford Thunderbird - Nascar

- 1/12 Scale 0.30 Lexan Bodies**
- AP4130 Turbo 330 ZX
  - AP4134 Toyota GTP
  - AP4141 '89 Jaguar GTP
  - AP4142 Toj 1/10 Scale "On Road" Body
  - AP4143 '89 Mercedes GTP
  - AP4146 300 ZX (GTO)
  - AP4147 Ferrari F-40 (GTO)
  - AP4161 Ford Thunderbird - Nascar
  - AP4162 '89 Chevy Lumina - Nascar
  - AP4100 Mustang 5.0
  - AP4101 Toyota 90c GTP
  - AP4130 Turbo 300ZX
  - AP4135 Camara ASA
  - AP4148 Nissan RK-90 GTP
  - AP4163 Mercury Cougar GTO.

- AP3026 Optima Apache Warrior "Off Road" Body for Yokomo
- AP3030 Jeep Comanche Truck Body
- AP3031 '89 Chevy "Off Road" Race Truck
- AP3100 Mercedes Benz 500 SE
- AP3134 '88 Vette Outlaw Wedge
- AP3140 Porsche 962 GTP
- AP3141 '89 Jaguar GTP
- AP3142 Toj 1/10 Scale "On

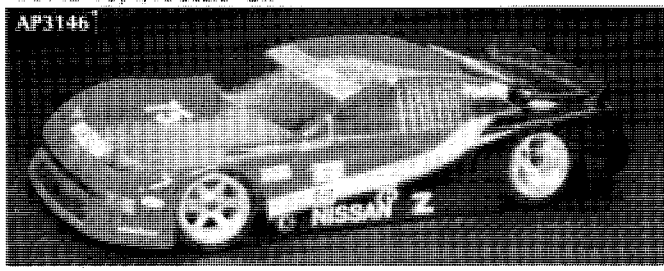
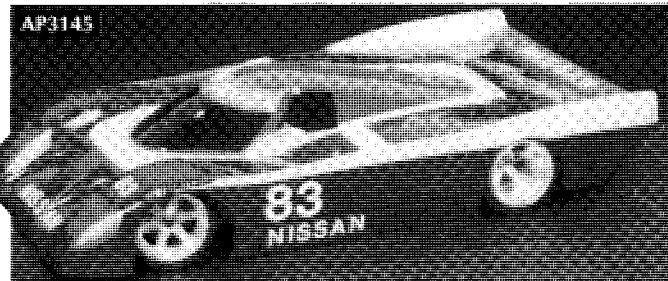

- AP3162 Chevy Lumina - Nascar
- AP3163 Mercury Ford Cougar (GTO)
- AP3135 Camaro ASA
- AP3148 Nissan RK-90 GTP
- AP3149 Audi Quatro

All bodies have superb detailing to give up a replica of the real thing.

- RC10 Components**
- AP3400 RC10 Wide Track Front Arms (Black)
  - AP3401 RC10 Wide Track Front Arms (White)
  - AP3402 RC10 Lightweight Rear Arms (Black)
  - AP3403 RC10 Lightweight Rear Arms (White)

- AP3410 RC10 4/40 Wide Front Steering Rods
- AP3411 RC10 Front Bumper Body Mount "Oval" (White)
- AP3412 RC10 Front Bumper Body Mount "Oval" (White) (Excellent for mounting saloon shell or monster truck)
- AP3413 RC10 Front Bumper Body Mount "Oval" (Black)
- AP3414 RC10 Short Front Bumper "Off Road" (White)

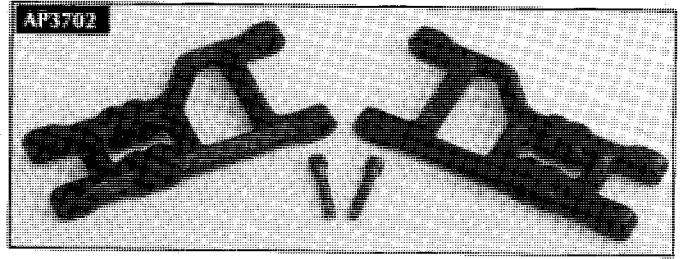
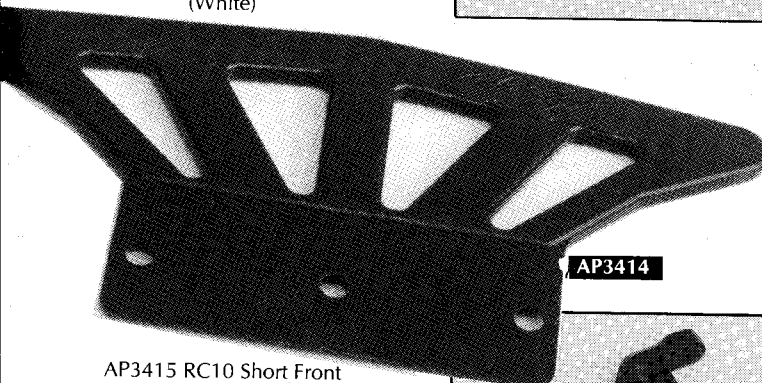
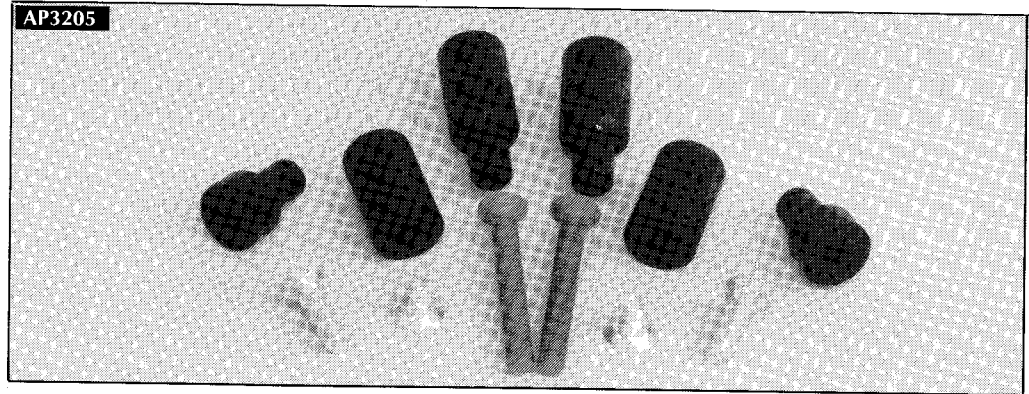

- AP3415 RC10 Short Front Bumper "Off Road" (Black)
- AP3416 RC10 Wide Front Bumper "Off Road" (White)

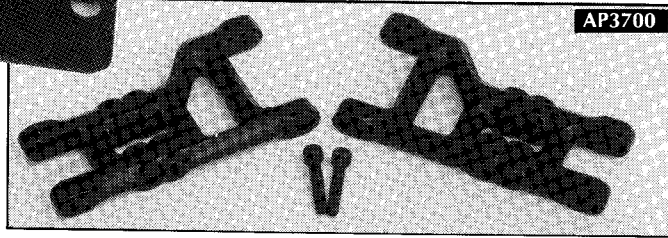

**JR-X2 Components**

- AP3023 Half-Breed "Off Road" JR-X2 Body
- AP3800 JR-X2 Lightweight Front Arms

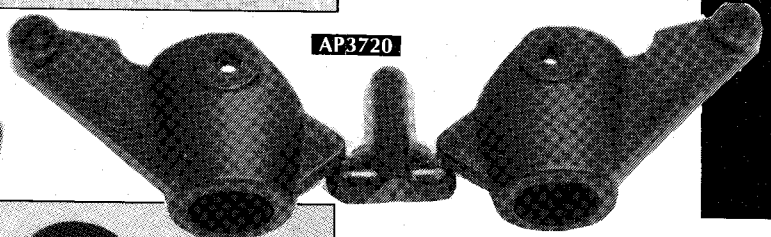
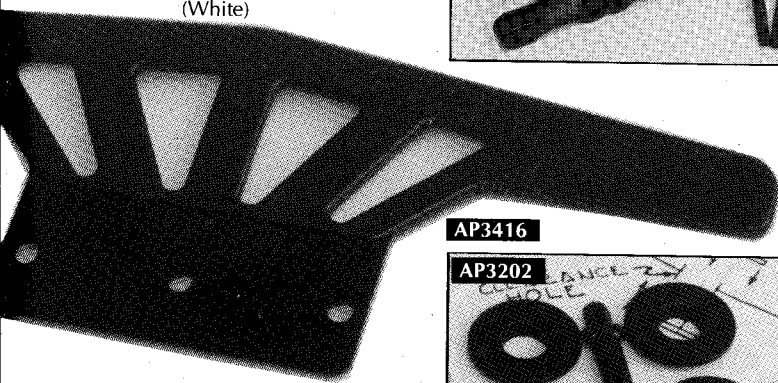

- AP3417 RC10 Wide Front Bumper "Off Road" (Black) (Suitable for saloon & monster truck shells)
- AP3418 RC10 Rear Body Mount (Black)

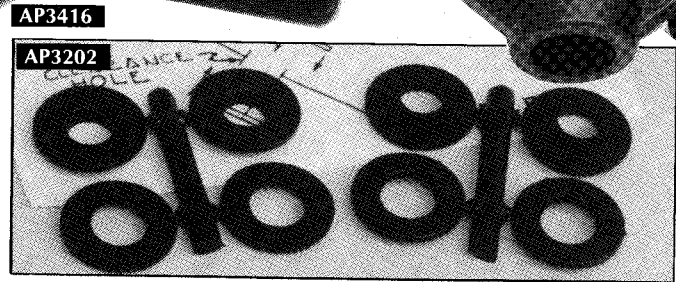

**Miscellaneous Accessories**

- AP2000 Andy's 'T' Shirt (S/M/L/XL)
- AP2010 Andy's Decal Pack (Black)
- AP2020 Andy's Decal Pack (Fluorescent)

**Yokomo Components**

- AP3700 Yokomo Lightweight Front Arms (Black)

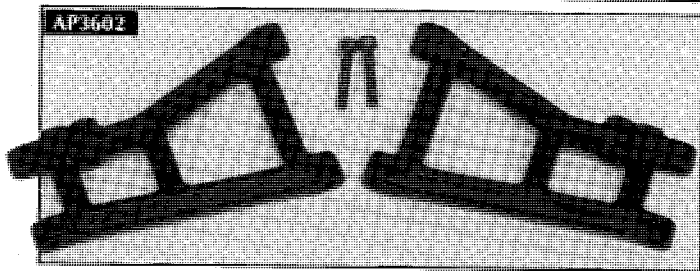
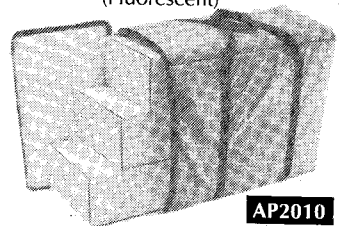
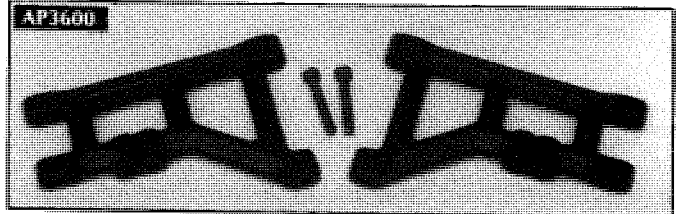

- AP3701 Yokomo Lightweight Front Arms (White)
- AP3702 Yokomo Lightweight Rear Arms (Black)
- AP3702 Yokomo Lightweight Rear Arms (White)
- AP3720 Yokomo Precision Nylon Hubs (Front) (Replaces magnesium blocks).

- AP2021 Andy's Hauler (Black/Blue/Silver) (Superb for all your pit accessories and spares. Will take three large boxes with a zip flap on the side. A must when travelling abroad.)
- AP2012 Andy's Tank Top (S/M/L/XL)



## Body Parts

- AP3201 Body Savers (white)
- Body Savers (Black)
- AP3202 Body Post Set
- 2 inch "On Road" Body
- AP3205 Post (Pr)
- 3 inch "On Road" Body
- AP3206 Post (Pr)
- 4 inch "On Road" Body
- Post (Pr)
- AP3207 Spoiler Material .030 8
- x 12
- Spoiler Material .030 8
- AP3208 x 12 5/8 wide, 45°
- angled edge
- Spoiler Material .030 8
- AP3221 x 12 5/8 wide, 45°
- angled edge
- Driver "Off Road"
- AP3222 Driver "Oval"
- Mid Optima Belly Pan
- 1/10 Scale "Off Road"
- Wing

AP 3470

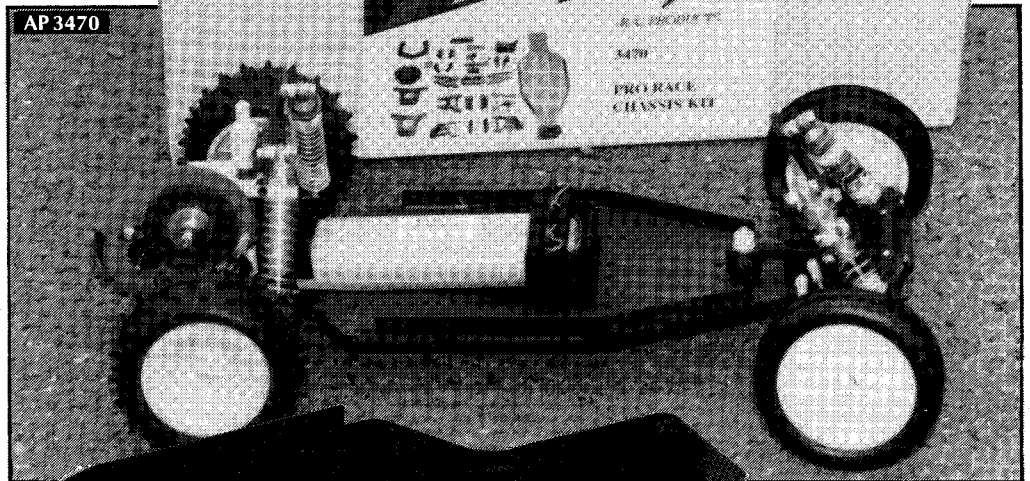

AP 3460

**SCAT**  
RACING PRODUCTS

28



## Pro Race Components

- AP3450 Pro Race Front Arms
- AP3451 Front Castor Blocks (20°)
- AP3452 Front Spindle B locks
- AP3453 Front Axle (In Line)
- AP3454 Rear Trailing Arms & Blocks
- AP3455 Rear Hub Block
- AP3456 Rear Suspension Mounts
- AP3457 Steering Rack and Bellcrank (w/bearing)
- AP3458 Front Bulkhead
- AP3459 Rear Hub Block (Oval)
- AP3460 Graphite Chassis (Pro Kit)
- AP3464 Front Shock Tower (Pro Kit)
- AP3465 Rear Shock Tower A-Arm (Pro Kit)
- AP3467 Battery Box
- AP3468 Rear Bulkhead
- AP3470 Graphite Pro Race Kit

## RC10 Pro Race Kit

This kit upgrades your RC10 to the latest race spec. It consists of all new suspension arms, blocks, steering arms/spindles, ballraced steering, option of trailing arm rear suspension, graphite shock towers, and moulded graphite chassis.

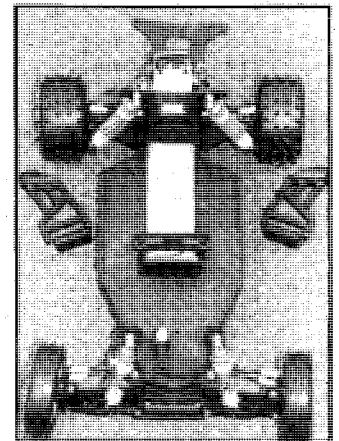

## Lazer Components

- AP3509 Lazer Front Body Mount
- AP3519 Lazer Rear Body Mount

## R/C Monster Truck Components Conversion

- AP3410 RC10 Monster Truck Widefront 4/40 Steering Rods
- AP3420 RC10 Monster Truck Front Body Mount
- AP3421 RC10 Monster Truck Front Spindles
- AP3422 RC10 Monster Truck Wheel Adaptors and Barrel Nuts
- AP3425 RC10 Monster Truck Conversion Kit (inc. Jeep Body) (Also available painted)

## ULTIMA COMPONENTS

- AP3500 Ultima Wide Track Front Arms (Black)
- AP3512 Ultima Front Bumper/Body Mount (Black)
- AP3514 Ultima Short Front Bumper "Off Road" (Black)
- AP3516 Ultima Wide Front Bumper "Off Road" (Black)

## Mid Optoma Components

- AP3600 Mid Optima Lightweight Front Arms
- AP3602 Mid Optima Lightweight Rear Arms
- AP3620 Mid Optima Precision Nylon Front Hubs

SEE CML PRICE LIST FOR COMPLETE LISTING

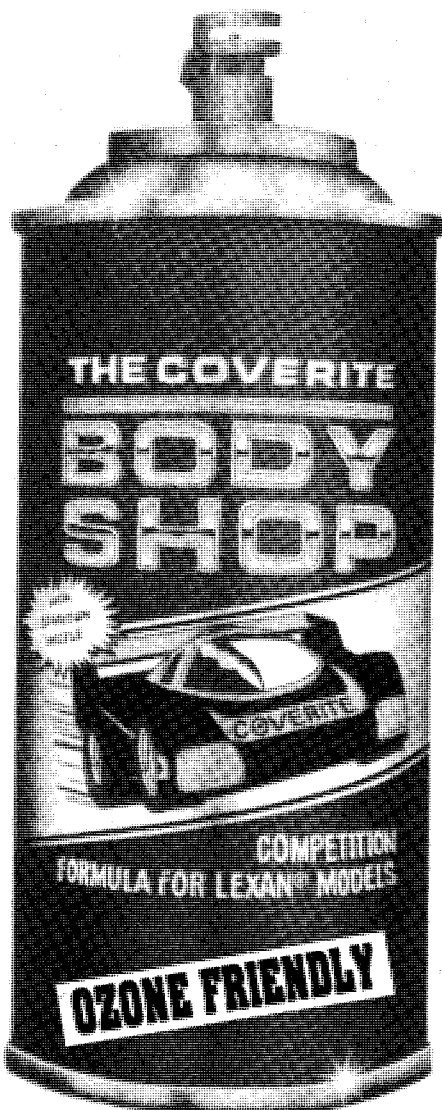

Rich Muise

"For an easy multi-color paint job, I use Coverite's new BodyShop products. No masking required, except for the windows. And only one can of paint! The trick is using Coverite's stripes, stars, alphabets, trimsheets and WindowMask. All self-adhesive - all stick to Lexan® like bugs on flypaper. Color is on **both** sides so they can be used on the inside or outside.

**"BODYSHOP PAINT IS PURE MAGIC"**

"It comes in a man-sized 6-ounce can instead of those itty-bitty 4 ounce cans. The colors are awesome:"

- 101 Whizzer White
- 102 Red Hot
- 103 Orange Orange
- 104 Varoom Maroon
- 105 Mid Ocean Blue
- 106 Vader Black
- 107 Mellow Yellow
- 108 Bruiser Blue (Met.)
- 109 Gold Rush (Met.)
- 110 Nevada Silver (Met.)
- 111 Smokey Gray (Met.)
- 112 Slightly Blue (Met.)

"Take a good look at the Chevy Lumina below. I did it with BodyShop spray cans - not an airbrush! The paint is actually metered so it comes out in a finer mist.

**BODYSHOP WINDOWMASK**

"Instead of cutting strips from rolls, I cut the whole window from the 6" x 12 1/2" Window-Mask. Enough for a whole car. BodyShop paint never leaks under it."

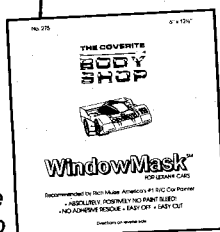

**BODYSHOP PINSTRIPES**

"These stripes are the best. They stay down even on 90° angles. Each sheet has 5 sizes, total 50 ft. 7 colors."

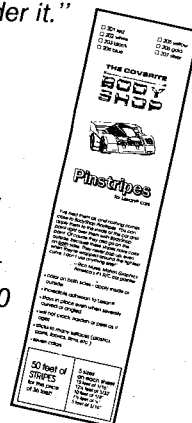

**PRESTO TRIMSHEETS**

"I cut out logos, gas caps, racing numbers, bumpers. Stick 'em inside or out. 6" x 12 1/2" sheets. Enough for several cars. 9 colors including real metalflakes."

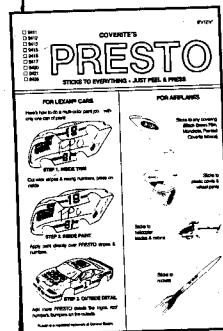

**GRAPHICS STARS, ETC.**

"Each star is diecut, so you just peel'n press. Stars in 4 sizes, 62 per sheet. Also 1/4" & 1/2" numbers & letters on 1 sheet. 5 colors.

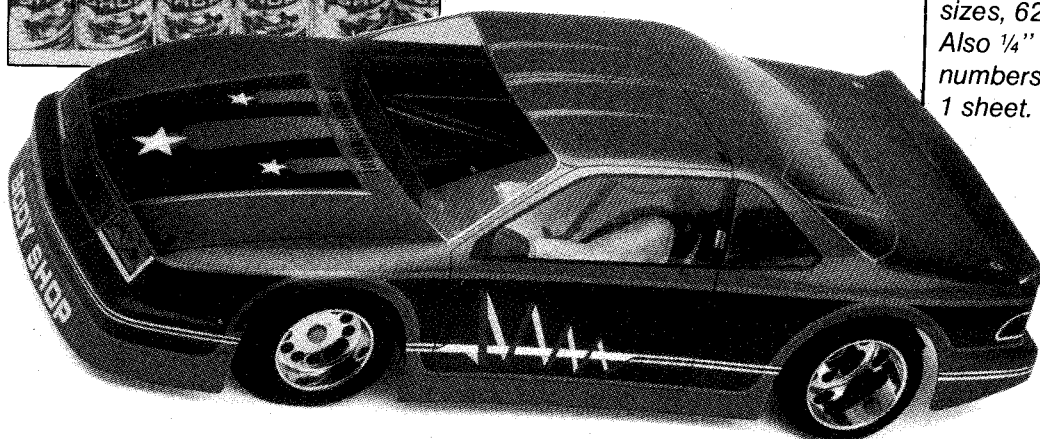
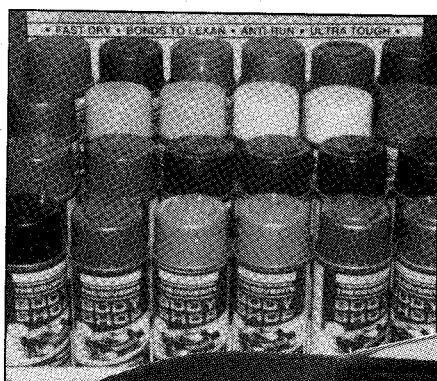

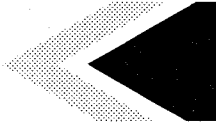

**"Jammin' Jay" Halsey**  
 FIRST EVER I.F.M.A.R.  
 OFF-ROAD WORLD CHAMPION  
 FIRST EVER R.O.A.R.  
 OFF-ROAD NATIONAL CHAMPION

To win, and keep winning it takes preparation, practice, and the right equipment. I designed Jammin' products to provide quality performance parts to all levels of competition, whether you're just playing or racing to win.

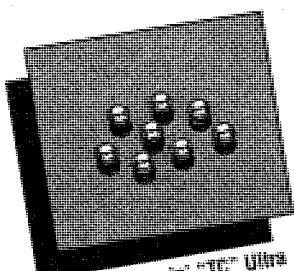

**J-101 Jammin' Ultra Hard 1/8" Diff Balls**  
 Precision grade 25 tungsten carbide balls for the RC-10 and similar differentials using 1/8" balls.  
 The extreme hardness greatly slows wear and eliminates the "notchy" feeling of other balls. I have run the same balls and pressure plates for over six months at a time without problems. These balls make a difference!

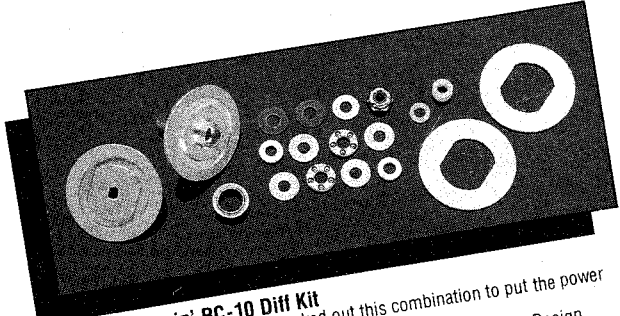

**J-105 Jammin' RC-10 Diff Kit**  
 Over years of racing I've worked out this combination to put the power to the ground. It works!  
 Complete differential kit includes: **J-106** Unique All-In-One Design Aluminum Diff Hub, **J-107** Machined Aluminum Outer Diff Hub, **J-108** Special Hardened and Ground Drive Rings, **J-109** Miniature Thrust Bearing Assembly, **J-418** Precision Diff Tube Ball Bearing.  
 Exclusive "Jammin'-Lock" design features double-flat drive with larger diameter diff hubs for positive support for the drive rings to eliminate spinning and deflection of the most critical part of your drive train. The gear is fully ball-bearing supported. The Aluminum Outer Hub employs a secondary Thrust Bearing to eliminate torque loads from the adjustment nut. Unique one-piece Diff Tube offers minimum drag and maximum support across its width. Miniature Thrust Bearing between the transmission pinions allows easy removal of the diff assembly and provides ultra-smooth operation.  
 I recommend J-101 carbide balls and J-210 gear lube for best results.

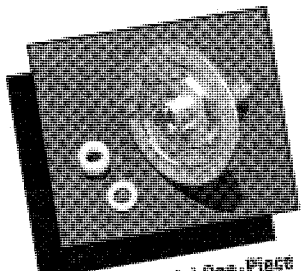

**J-106 Jammin' One-Piece Machined Aluminum RC-10 Ball Bearing Diff Tube**  
 Larger diameter. Uses J-108 Drive Rings. Includes teflon inserts.

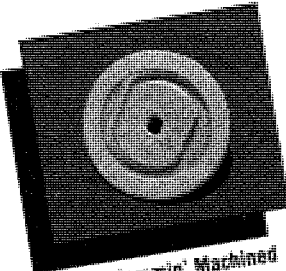

**J-107 Jammin' Machined Aluminum Outer Hub**  
 Larger diameter. Uses J-108 Drive Rings and J-109 Miniature Thrust Bearings.



**J-108 Jammin'-Lock Drive Rings**  
 Ultra-hard heat treated and precision ground for longer life and smoother operation. Must use J-106 Diff Tube and J-107 Outer Hub.

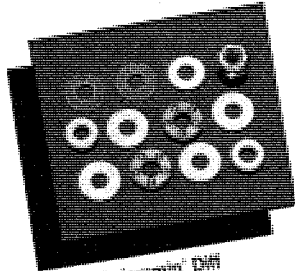

**J-109 Jammin' Diff Rebuild Kit**  
 Includes Special Spacer/Washers, 2 Miniature Thrust Bearing Assemblies, Belleville Washers and 5-40 Lock Nut.

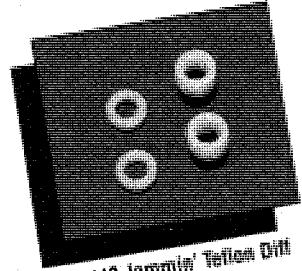

**J-110 Jammin' Teflon Diff Tube Inserts**  
 Minimize friction with exceptional support and life. 2 long and 2 short. Used on J-106 Diff Tube.

**COMING SOON!**

**J-118 Jammin' RC-10 Gear Cover**  
 Big enough to clear the oversized spur gears that are sometimes necessary, yet allows easy access to diff adjustment nut. I wouldn't think of running without a cover, neither should you.

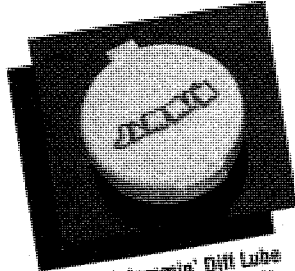

**J-120 Jammin' Diff Lube**  
 Special silicone based paste allows you to run the Jammin' diff extremely loose without slippage.

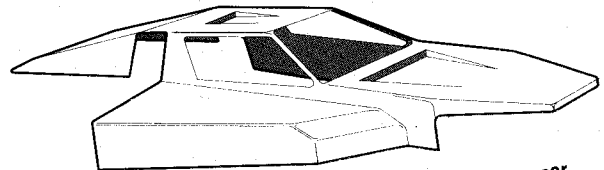

**J-201 Jammin' Jumper Buggy Body**  
 For the RC-10. Features a customized design for great in-air and on the ground handling, as well as keeping things clean.

**J-211 Jammin' Jumper Custom Painted Body**  
 Vibrant neon, candy, and accent colors.

SEE CML PRICE LIST FOR COMPLETE LISTING

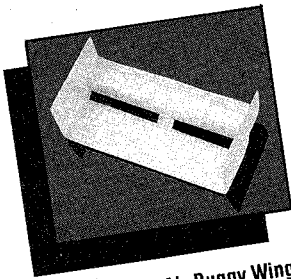

**J-220 Jam Air Buggy Wing**  
Special Lexan Wing. The right combination of wing, vertical lip, and side dam needed for a winning RC-10.

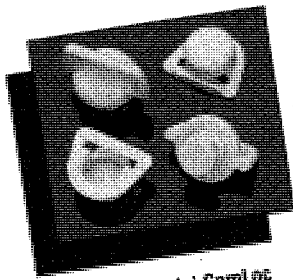

**J-225 Jammin' CamLoc Wing Mounts**  
Easy to use mounts make adjustments a snap... a simple turn of the wrist. No special tools needed for this critical tuning aid.

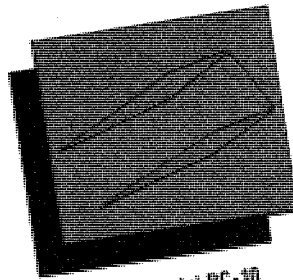

**J-226 Jammin' RC-10 Wing Wire**  
Made from .070 music wire for maximum strength and durability. The best part is it's pre-bent, no tricky bending, no scrap wires.

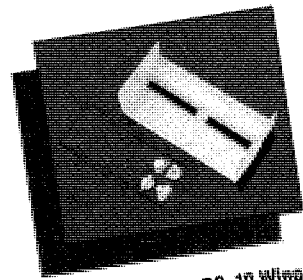

**J-230 Jam Air RC-10 Wing Kit**  
Includes the J-220 special Lexan wing, J-226 pre-bent wing wire, and two J-225 CamLoc adjustable mounts.

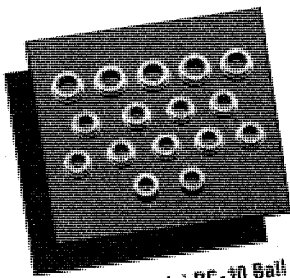

**J-410 Jammin' RC-10 Ball Bearing Set**  
Absolutely the finest, highest quality, most reliable ball bearings available. Jammin' bearings feature precision stainless steel construction with exclusive low-drag lubricant for the best possible performance. I need to run the best and these bearings are just that.

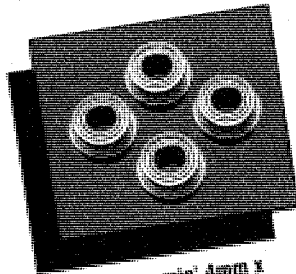

**J-415 Jammin' 4mm x 8mm Flanged Bearings**  
These are my choice for my winning Yokomo YZ-10. Since these bearings are so small, strength and load carrying capability is critical. These stainless steel units exceed the need for long life and durability.

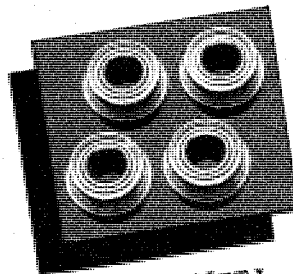

**J-416 Jammin' 5mm x 10mm Flanged Bearings**  
The best bet for your Yokomo, Kyosho, or similar off-road car. Like all Jammin' bearings, they feature stainless steel construction, non-contact shields, and special lubricant that minimizes friction and extends life.

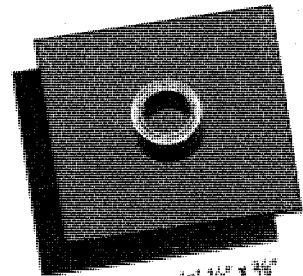

**J-418 Jammin' 1/4 x 3/8 Diff Tube Bearing**  
Precision stainless steel construction. Use with J-108 Diff Tube.

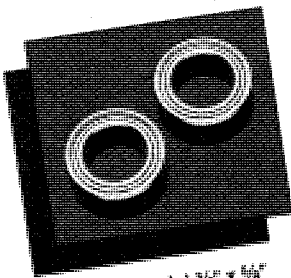

**J-420 Jammin' 3/8 x 3/4 Outdrive Bearings**  
Extra support with absolute minimum amount of friction.

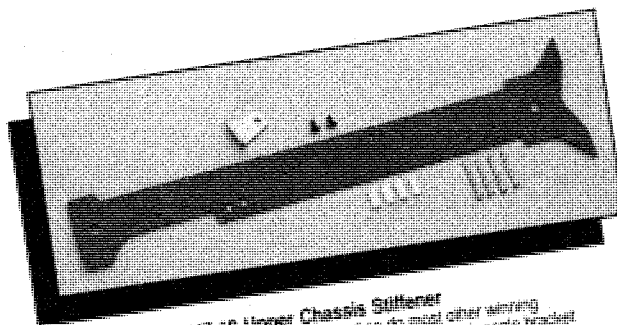

**J-501 Jammin' YZ-10 Upper Chassis Sulfener**  
A must for serious competition. I use it and so do most other winning YZ-10 drivers. Makes chassis rigid and eliminates the stock angle bracket and provides more room for radio and batteries. Added reinforcement to chassis and shock mounts decreases bulkhead breakage and increases performance dramatically. Includes belt tensioner bracket, screws and special spacers.

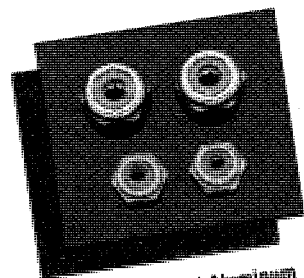

**J-901 Jammin' Aluminum Nylock RC-10 Wheel Nuts**  
4-40 front and 8-32 rear. Lightweight aluminum wheel nuts with locking inserts for added insurance under toughest conditions.

## Jammin' Jay Halsey Hats, Shirts and Stickers

**J-801 Jammin' Jay Halsey Logo/Sticker Sheet**  
2 sheets of logos and racer's sayings one for light cars, one for dark cars.

**J-810 Jammin' Jay Halsey Racing Hat**  
Colorful Jammin' Jay Halsey Products logo on quality hat. One size fits all.

**Jammin' Jay Halsey T-Shirts**  
J-811 Small  
J-812 Medium  
J-813 Large  
J-814 XL  
J-815 XXL

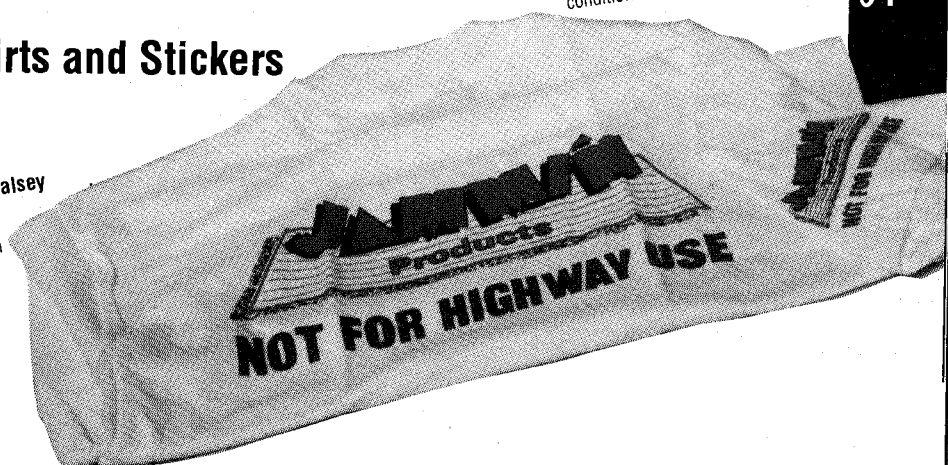

### SM002 Yokomo Aluminium Front Arms

Machined from aluminium with a superb finish to give unbreakable performance

### SM003 Yokomo Aluminium Rear Arms SM005 Yokomo Protech Body and Undertray

Direct Replacement over standard shell

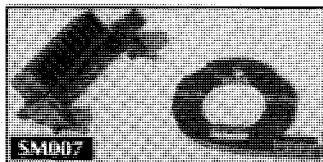

### SM007 Yokomo A and B Heatsink Set

Two piece heatsink set. One finned heatsink bolts across the centre shaft with the second A heat sink plate which bolts between motor and motor mount and then is bolted to the first heatsink connecting the two for maximum heat dissipation, providing more speed and motor life.

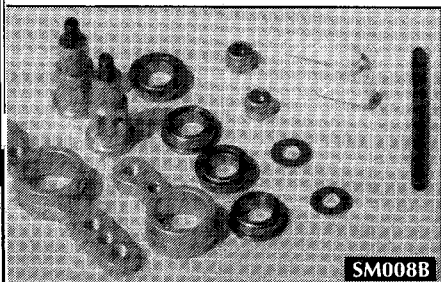

### SM008B Yokomo Ballraced Servo Saver

Consists of two machined alloy bellcranks, machined alloy posts and centre track rod and all necessary hardware. Reduces slop and wobble.

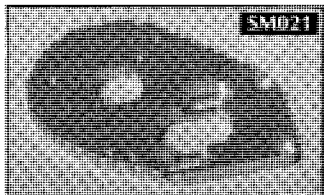

### SM021 MID 4 Motor Plate Heatsink

Machined finned aluminium plate which is a direct replacement. Fits MID4 Custom/special and all other mid 4 cars.

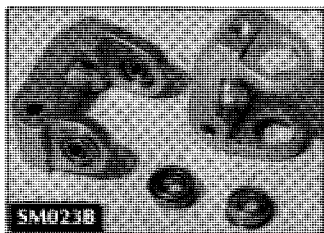

### SM022 MID 4 Aluminium Front Arms

Direct replacement

### SM023B MID 4 and Yokomo Ballraced Hub Carrier

Aluminium carriers machined for bearings. Improving steering and reducing slop.

### SM024 MID 4 Aluminium Rear Arms SM025 MID 4 Wheel Set (4)

These wheels are available in Green/White and are made to accept sponge tyres

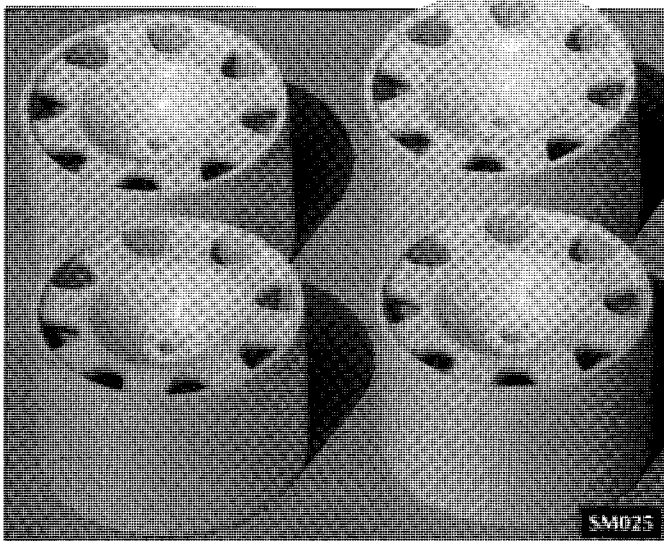
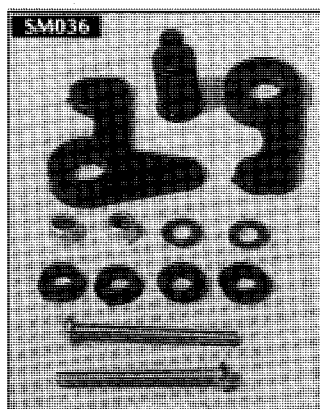

### SM026 MID 4 Driveshafts

Made from lightweight aluminium with a hard chrome finish, these offer a significant reduction in weight with no loss in strength.

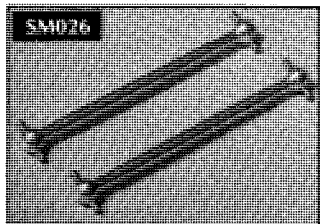

### SM027 MID 4 Joint

Replacement gearbox joint.

### SM028 MID 4 Front Shaft

Gold anodised replacement half shaft. Considerably lighter than stock.

### SM029A MID Custom 'L' Body with undertray

Direct replacement

### SM031 MID 4 Rear Shaft

Lighter replacement over stock ones

### SM034 Motor Heatsink Plate

Universal heatsink for any car. Finned for better heat dissipation

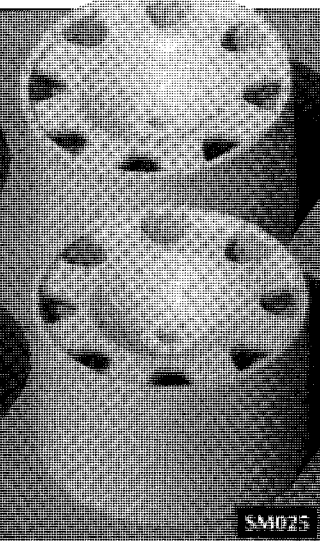

### SM035 MID 4 Middle Gear

Replacement centre idler gear

### SM036 Universal Plastic Steering Set

Consists of two bellcranks, posts and four plastic bushes.

However the bushes can be replaced with bearings if desired. Can be adapted to many cars giving improved performance.

### SM037 Springs Clamps and Cups

Made from aluminium



### SM043/44 BBS/10 On Road Wheels

Available in both pink and purple

### SM045 Speed Controller Heatsink (4)

Made from aluminium

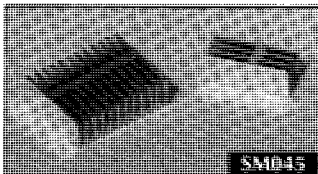

### SM046 MID 4 Wheel Set Off Road

Narrow front wheels, standard width rears - orange colour, for off road tyres.

### SM047 Wheel Adaptor for Tamiya to accept Kyosho Wheels

### SM048 Yokomo Wheel Set Off Road (4)

Same as SM046 but Yokomo fitting



### SM052 Kyosho Adaptors to fit Tamiya to Kyosho

### SM053 Battery Heatshrink Pack

Consists of two strips of clear single cell heatshrink, one strip of red double heatshrink and two plastic end caps to protect battery ends.



### SM054 BBS Wheel Adaptors

Available for CAT/Tamiya/Kyosho - Set of 4.

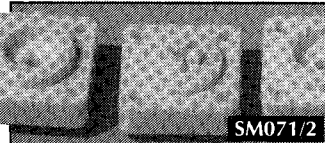
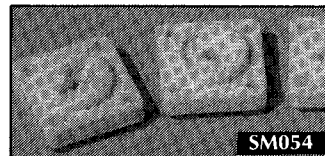

### SM055B MID 4 Ballraced Steering Set

### Replacement steering as SM008B but for Mid 4

### SM056 Mid 4 Wheel Set on Road (4)

Narrow fronts, wide rears in orange. However they have a flat profile to ease the gluing of sponge tyres.





**SM057 MID 4 Front and Rear Nylon A Arm Set**

Machined white nylon arms.

**SM058 Yokomo Wheel Set on Road (4)**

Same as SM056 but for Yokomo

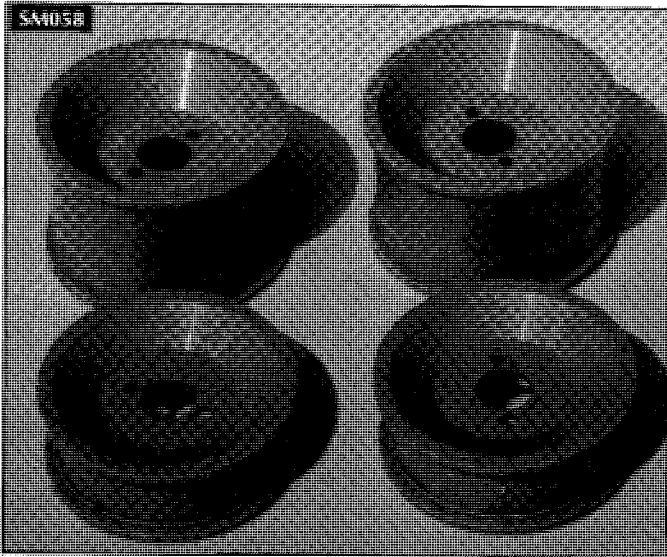
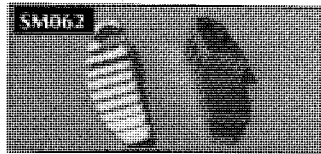

**SM059 MID 4 Middle Heatsink**

Replaces plastic centre section moulding which separates motor plate from the other side with a finned aluminium piece.

**SM060 MID 4 Spur Gears 6 Module**

Moulded. 6 Spur Gears available in the following sizes: 69T/70T/72T/74T

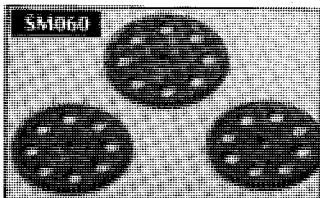

**SM061 Kyosho Burns Centre Differential Blocks with Bearings**

Alloy diff. block, replaces standard nylon units and comes complete with two bearings

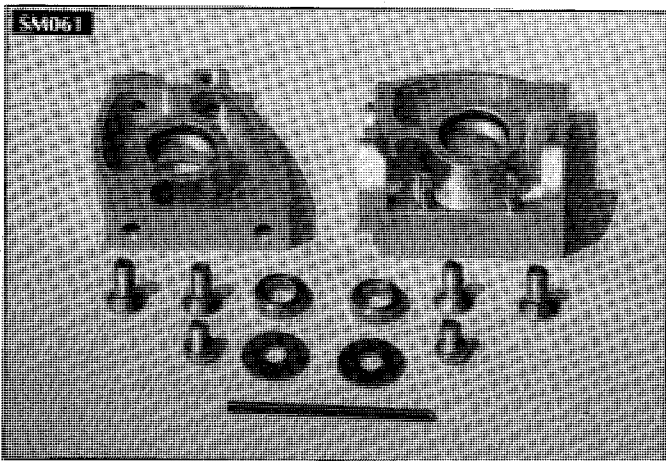

**SM062 Motor Divide Heatsink (2)**

Finned heatsink piece which bolts, one either side of the endbell on the brush screw. This reduces heat build up of the brushes

**SM063 Motorcycle Gear Box Heatsink**

Aluminium finned heatsink

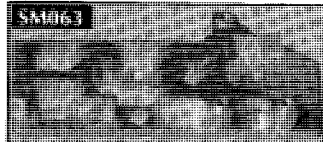

**SM065 Kyosho Burns Wing Mount**

Aluminium replacement wing mount - for a stronger, sturdier, wing support

**SM070 Kyosho Laser Motor Heatsink Plate**

Replacement motor plate in finned alloy

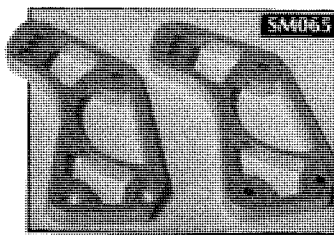

**SM071/1 Motor Heatsink Plate**

For Tamiya C54 Motor

**SM071/2 Motor Heatsink Plate**

For any motor except Tamiya

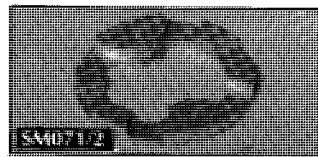

**SM072 Kyosho Laser Front Arm Bracket (2)**

Alloy brackets for improved strength



**Speed Model Pro Peak Charger**

Mosfet pulse current charger. Delta Peak automatic cut off system. Fixed charger rate at 1.5/3A/4.5A or adjustable from 0.8A to 9A. Digital DVM Display for amps and volts. Lightweight and compact. Superb value.

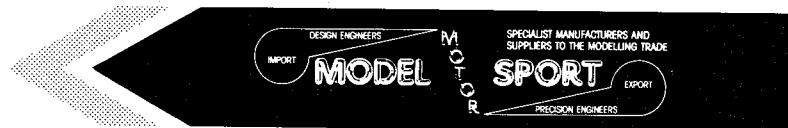

**Model Motor Sport**

Model Motor Sport is a name that is known throughout racing circles as a name for quality and race winning components. None of these add on parts are cosmetic - they really do work and make all the difference between winning and losing.

**ProCat/CAT XLS**

**MMS01 Pro Cat 14 Ball Tri Pulley Diff.**

A unique one piece diff pulley, this unit replaces the standard three pulley set up, resulting in a much more accurate and more efficient drive train giving better speed and duration.

**MMS02 Pro Cat Top Layshaft Pulley**

This unit replaces the complete top layshaft thrust bearing/diff assembly. It is totally fixed and so has to be used in conjunction with MMS01 but again it provides a much smoother more efficient drive.

**MMS03 Pro Cat Front Pulley 51T**

To complete the set and get the maximum from your car the front pulley is essential. Comes ballraced and has two flanges to guide the belt giving it a definite advantage over the standard pulley.

**MMS08 Pro Cat Super Tri Pulley Diff**

This is exactly the same as MMS01 other than it has flanges machined into it to guide all the belts giving trouble free running and eliminating the risk of the belts crossing over.

**MMS06 Pro Cat Sideplate and Linkage Support Bracket**

This is bolted between the two sideplates of the gearbox replacing two small plastic dividers. Due to it being one piece it provides a much more rigid and more accurately aligned gearbox.

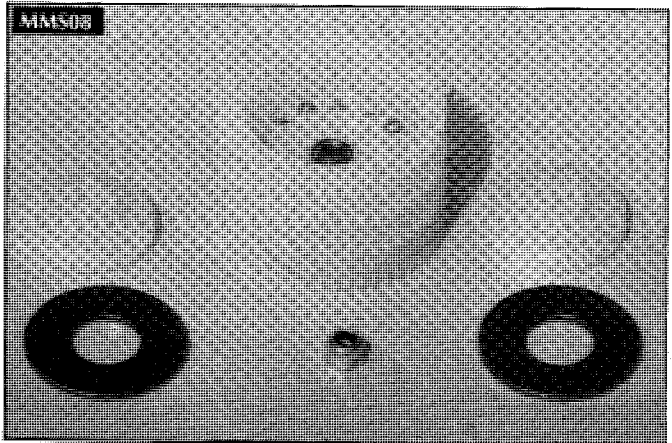

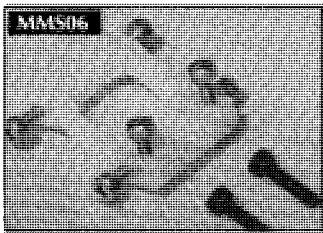

**MMS07 Pro Cat Top Gearbox Heatsink**  
 This slots between the two gearbox sideplates above the motor. It is finned and available in black/blue/red colours.

**MMS11 Cat Sideplate Heatsink**

This bolts to the motor mounting gearbox plate and is also available in black/red/blue. Cougar/TopCat

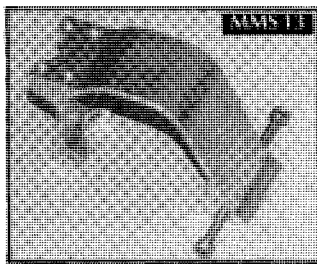
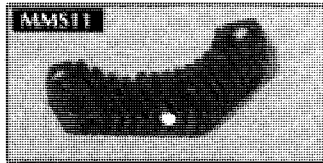

**MMS04 Cougar Diff Pulley**

Similar to MMS01 but made for the Cougar

**MMS05 Cougar Top Layshaft**

**MMS14 Aluminium Procat Side Plate Suspension and Linkage Support Bracket**

**MMS13 Aluminium Inner Transmission Housing**

**MMS18 Kyosho Lazer Heatsink** fits outside face of Motor Plate.

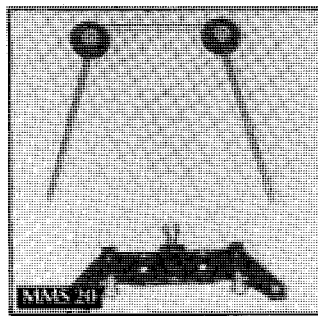

**MMS19**

**MMS19 Pro Cat Steering Arm**

**MMS20 Pro Cat Wing Mount w/Transponder plate and wire**

**MMS22 Cougar Aluminium Wing Mount and wire.**

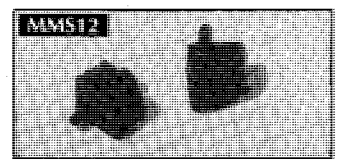

**Miscellaneous**

MMS09 Pressure Pads 14 Ball (Pr)  
 MMS10 Diff Repair Kit 14 Ball (Pr)  
 MMS12 Motor Brush Heatsink (2) Screws to brush scress.

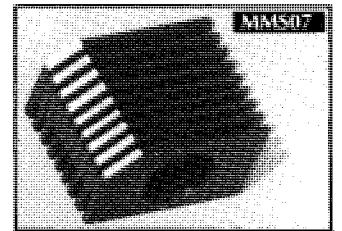
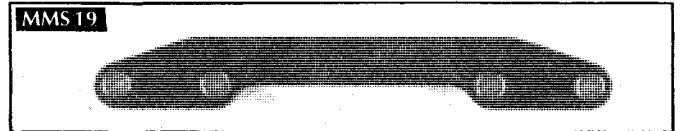

**CML ACCESSORIES**

**CML01 Decal Sheet**

Fluorescent A4 Decal Sheet with various Yokomo, Team Losi, Revolution, Primetime, Novak and Proline Logos

**CML01**



bulkhead caps allowing it to sit flush and butt up to the caps forming a rigid no flex set up. Comes with screws.

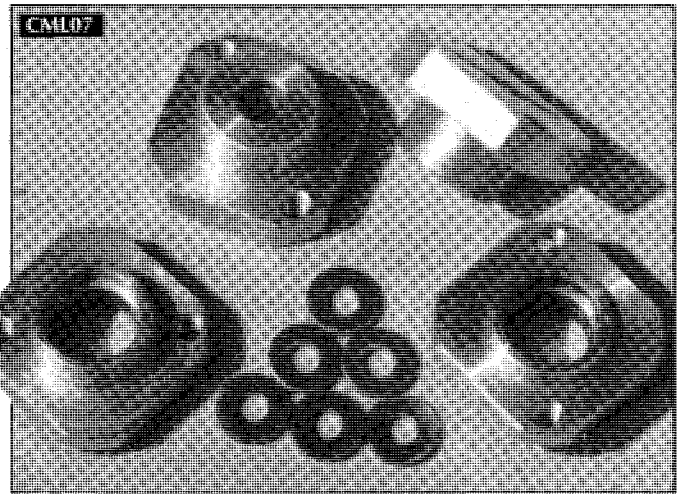

**CML07 JR-X2 Wheel Adaptors for Yokomo Wheels**  
**CML15 Heatshrink** Twin stick and single stick (Clear/Red)

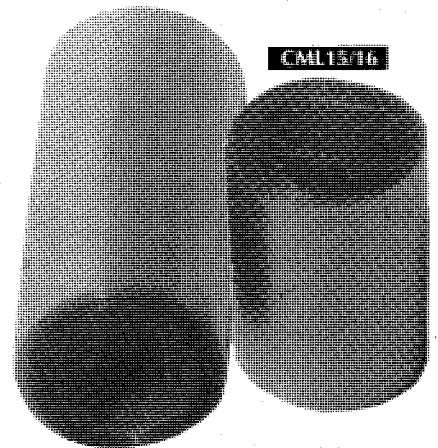

**CML15/16**

**CML02 CML Yokomo Top Brace**

This top brace bolts down in four places, over the front and rear bulkheads. It is milled at the correct angle to the

**CML05 Yokomo Nylon Front Bulkhead**

Quality machined nylon 66 bulkhead. Improved design 3° extra kick up for improved ride over rough ground and better steering at speed. Bearing slots, snap fit.

# Andy's

R/C PRODUCTS

AP3143 SAUBER MERCEDES



AP3162 CHEVY LUMINA



AP3141 JAGUAR

AP3163 FORD COUGAR



AP3146 NISSAN 300 ZX



# LOOKIN' GOOD!



AP3145 NISSAN GT-R

AP3142 TOJ



AP3161



THUNDERBIRD

ALL ANDY'S R/C PRODUCTS ARE DISTRIBUTED BY:



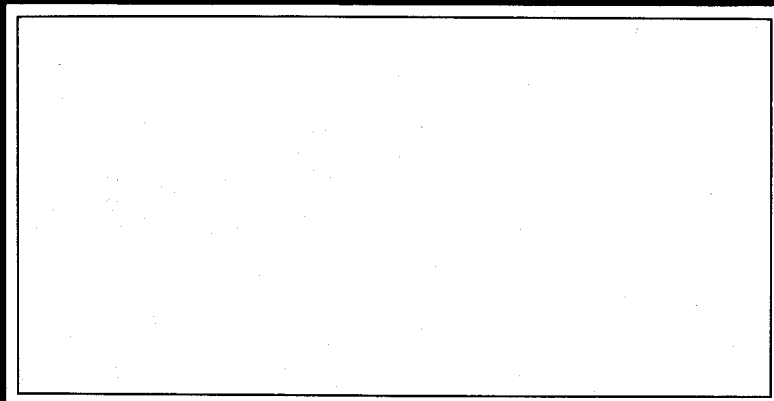

**CML DISTRIBUTION**  
**1684 BRISTOL ROAD SOUTH, REDNAL**  
**BIRMINGHAM, B45 9TZ, ENGLAND**  
**TEL: 021-453-9631 FAX: 021-453-2742**