

# C4.1CENTRO

**DRIVER:** \_\_\_\_\_  
**TRACK:** \_\_\_\_\_  
**EVENT:** \_\_\_\_\_  
**DATE:** \_\_\_\_\_

## Front End

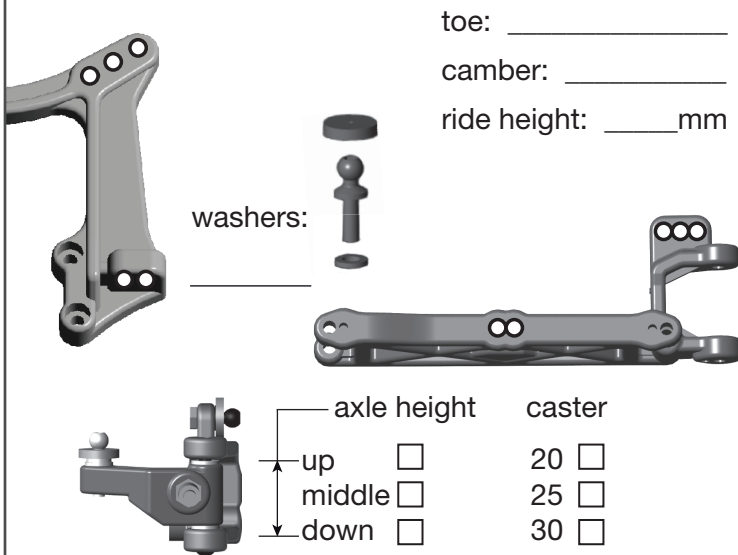

toe: \_\_\_\_\_  
 camber: \_\_\_\_\_  
 ride height: \_\_\_\_\_mm

washers: \_\_\_\_\_

axle height    caster

up        20   
 middle     25   
 down     30

## Rear End

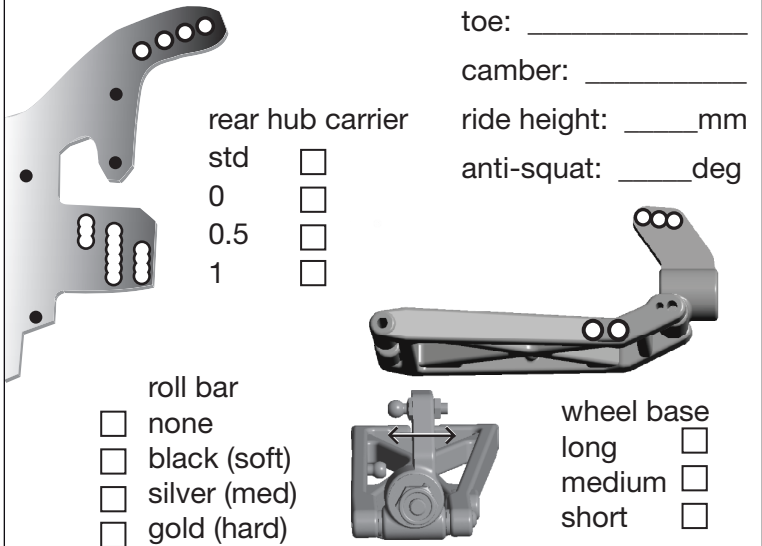

toe: \_\_\_\_\_  
 camber: \_\_\_\_\_  
 ride height: \_\_\_\_\_mm  
 anti-squat: \_\_\_\_\_deg

rear hub carrier

std      
 0      
 0.5      
 1   

roll bar

none  
 black (soft)  
 silver (med)  
 gold (hard)

wheel base

long      
 medium   
 short   

## Front Shocks

spring \_\_\_\_\_ piston \_\_\_\_\_  
 shock oil \_\_\_\_\_ limiter \_\_\_\_\_

## Rear Shocks

spring \_\_\_\_\_ piston \_\_\_\_\_  
 shock oil \_\_\_\_\_ limiter \_\_\_\_\_

## Front Tires

tire: \_\_\_\_\_ compound: \_\_\_\_\_  
 insert: \_\_\_\_\_ wheel: \_\_\_\_\_

## Rear Tires

tire: \_\_\_\_\_ compound: \_\_\_\_\_  
 insert: \_\_\_\_\_ wheel: \_\_\_\_\_

## Electronics

motor & wind: \_\_\_\_\_  
 pinion: \_\_\_\_\_ spur gear: \_\_\_\_\_  
 batteries: \_\_\_\_\_ placement: \_\_\_\_\_  
 radio: \_\_\_\_\_ servo/ expo: \_\_\_\_\_/\_\_\_\_\_

throttle/ brake epa: \_\_\_\_\_/\_\_\_\_\_  
 throttle/ brake expo: \_\_\_\_\_/\_\_\_\_\_  
 esc: \_\_\_\_\_ throttle profile: \_\_\_\_\_  
 initial brake \_\_\_\_\_ drag brake: \_\_\_\_\_

## Body/Wing

body/ wing: \_\_\_\_\_  
 notes: \_\_\_\_\_

## Differential

gear differential/ oil: \_\_\_\_\_/\_\_\_\_\_  
 ball differential/ setting: \_\_\_\_\_/\_\_\_\_\_

## Race/ Car/ Notes

qualify: \_\_\_\_\_ main: \_\_\_\_\_ finish: \_\_\_\_\_  
 \_\_\_\_\_  
 \_\_\_\_\_  
 \_\_\_\_\_  
 \_\_\_\_\_

## Weight distribution

bulkhead

std      
 brass   
 alloy

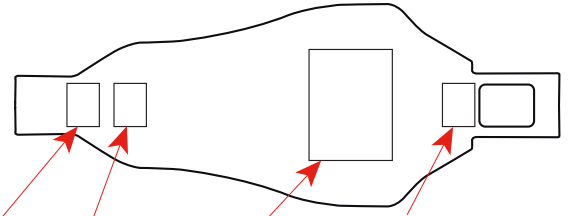

\_\_\_\_\_g    \_\_\_\_\_g    \_\_\_\_\_g    \_\_\_\_\_g