

Front Suspension

Ride Height: \_\_\_\_\_  
 Camber: \_\_\_\_\_  
 Toe: \_\_\_\_\_  
 Anti-Roll Bar: \_\_\_\_\_  
 Arm Type: \_\_\_\_\_  
 Tower Type: \_\_\_\_\_  
 Caster Block Insert: \_\_\_\_\_  
 Steering Block: \_\_\_\_\_  
 Bulkhead Type: \_\_\_\_\_  
 Kick-Up Angle: \_\_\_\_\_  
 Wheel Hex: \_\_\_\_\_

Bump Steer Spacing: \_\_\_\_\_  
 Steering Plate: \_\_\_\_\_  
 Steering Stop Spacing: \_\_\_\_\_  
 Axle Height: +3   
 +2   
 +1   
 0   
 SCH1256   
 Caster Block Spacing: \_\_\_\_\_

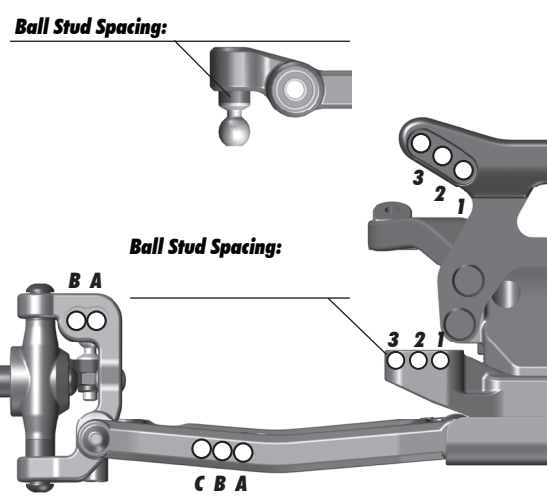

Notes

Rear Suspension

Ride Height: \_\_\_\_\_  
 Camber: \_\_\_\_\_  
 Tower Type: \_\_\_\_\_  
 Wheel Hex: \_\_\_\_\_  
 CVA Bone Length: \_\_\_\_\_  
 CVA Pin Location: \_\_\_\_\_  
 Anti-Roll Bar: \_\_\_\_\_  
 Arm & Position: 73  75  Forward  Back   
 Hub Spacing: Forward  Middle  Back   
 Shock Mounting Position: Front of Arm  Rear of Arm

C Mount Inserts: 1°  0.5°   
 Aluminum  Brass   
 D Mount Inserts: 1°  0.5°   
 Aluminum  Brass

Hub Insert: 3 (∅0/3∅)   
 2 (∅1/2∅)   
 1 (∅1/2∅)   
 0 (∅0/3∅)

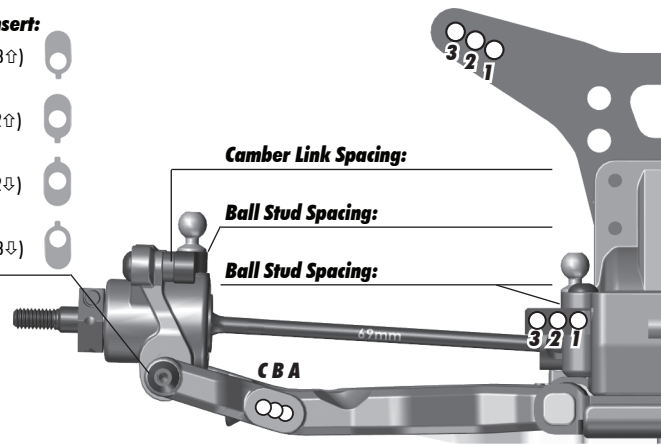

Notes

Track Info, Tires & Aero

Radio: \_\_\_\_\_ Servo: \_\_\_\_\_  
 EPA: Throttle: \_\_\_\_\_ % Brake: \_\_\_\_\_ %  
 ESC: \_\_\_\_\_  
 ESC Settings: \_\_\_\_\_  
 Motor: \_\_\_\_\_ Timing: \_\_\_\_\_  
 Pinion: \_\_\_\_\_ Spur: \_\_\_\_\_  
 Battery: \_\_\_\_\_ Battery Weight: \_\_\_\_\_  
 Battery Position: \_\_\_\_\_

Transmission  Laydown  Layback  Stand-Up   
 3 Gear  4 Gear   
 Differential Height: \_\_\_\_\_  
 Ball Diff: \_\_\_\_\_  
 Gear Diff: \_\_\_\_\_  
 Slipper Type: \_\_\_\_\_  
 # of Pads: \_\_\_\_\_

Shocks	Front	Rear
Piston:		
Fluid:		
Spring:		
Int. Limiter:		
Ext. Limiter:		
Stroke:		
Eyelet Length:		
Cup Offset:		
Notes:		

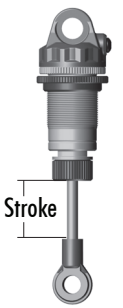

Size: Small  Medium  Large  Extra Large   
 Surface: Dirt  Carpet  Astroturf  Multi Surface   
 Traction: Low  Medium  High  Very High   
 Moisture: Dry  Damp  Wet   
 Condition: Indoor  Outdoor  Dusty  Hard Packed   
 Bumpy  Grooved  Smooth  Loamy   
 Temperature: Ambient: \_\_\_\_\_ Humidity: \_\_\_\_\_

Front Tires: \_\_\_\_\_  
 Front Compound: \_\_\_\_\_  
 Front Insert: \_\_\_\_\_  
 Rear Tires: \_\_\_\_\_  
 Rear Compound: \_\_\_\_\_  
 Rear Insert: \_\_\_\_\_  
 Wheel (F/R): \_\_\_\_\_

Body: \_\_\_\_\_  
 Wing: \_\_\_\_\_  
 Wing Angle: 0°  3°  6°   
 Front Wing: \_\_\_\_\_  
 Chassis Length: \_\_\_\_\_  
 Servo Weights: \_\_\_\_\_  
 Electronic Weights: \_\_\_\_\_  
 Total Vehicle Weight: \_\_\_\_\_

Notes

Notes

Comments