

Front Suspension:

Reset Forms

Ride Height:	17MM
Camber:	-1
Toe:	SLIGHT TOE OUT
Arm Type:	GULL HARD
Tower Type:	GULL KIT
Caster Block Insert:	5 UP
Steering Block:	4
Bulkhead Type:	BRASS
Kick-Up Angle:	25
Wheel Hex:	TITANIUM
Notes:	1MM SHIM BETWEEN BULKHEAD AND CHASSIS PROLINE FRONT WING, CUT MIDDLE

Anti Roll Bar:

White (0.8mm)

Gray (0.9mm)

Blue (1.0mm)

Other:

Bump Steer Spacing: NONE

Axle Height:

+3

+2

+1

0

Ball Stud Spacing: 1

Steering Plate: +1

Steering Stop Spacing: NONE

Ball Stud Spacing: 1

Caster Block Spacing: REAR

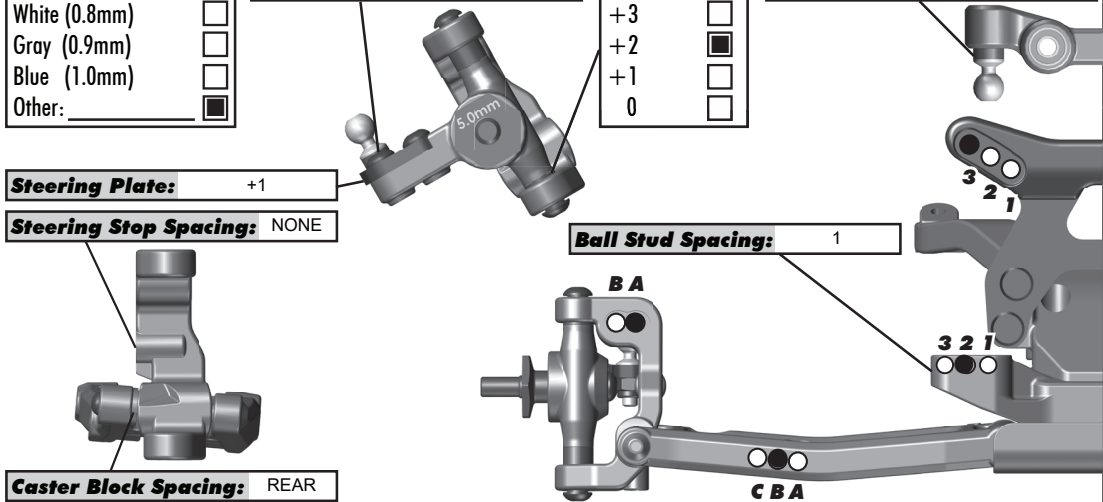

Rear Suspension:

Ride Height:	18MM
Camber:	-1
Tower Type:	KIT
Wheel Hex:	7MM
CVA Bone Length:	67MM
CVA Pin Location:	TOWARDS WHEEL
Hub Spacing:	Forward <input type="checkbox"/> Middle <input checked="" type="checkbox"/> Back <input type="checkbox"/>
Shock Mounting Position:	Front of Arm <input checked="" type="checkbox"/> Rear of Arm <input type="checkbox"/>
Notes:	

Anti Roll Bar:

White (1.2mm)

Gray (1.3mm)

Blue (1.4mm)

Other: NONE

Rear Hub Link Setting:

Plastic Hub Aluminum Hub Ball Stud Spacing:

Up: Down:

C Mount Inserts: 1° 0.5°

Aluminum Brass

D Mount Inserts: 1° 0.5°

Aluminum Brass

Hub Insert:

+3 +2 +1 0

Ball Stud Spacing: 3

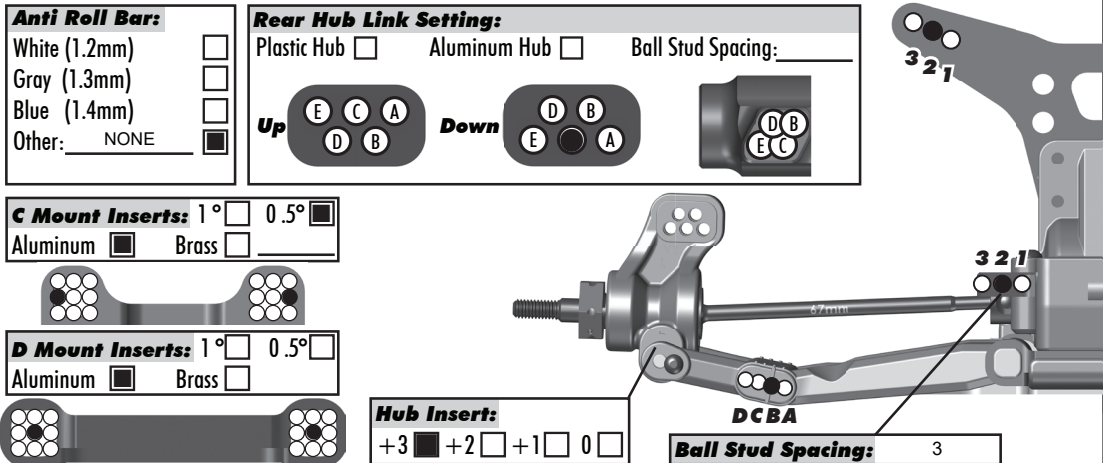

Electronics:

Radio: SANWA	Servo: SAVOX 1257TGB
EPA: Throttle: 100 %	Brake: 100 %
ESC: REEDY BLACKBOX 510R	
ESC Settings: 15DEG TOP SPEED, NO BOOST	
Motor: REEDY MACH 3	
Wind: 7.5	Timing: 30
Pinion: 24	Spur: 78
Battery: CENTRO 3200 LOW PROFILE	
Battery Position: FORWARDS 38G UNDER BATTERY	

Drivetrains:

Transmission:	Laydown: <input checked="" type="checkbox"/>
3 Gear: <input checked="" type="checkbox"/>	Layback: <input type="checkbox"/>
4 Gear: <input type="checkbox"/>	Stand Up: <input type="checkbox"/>
Differential:	Ball Diff: <input checked="" type="checkbox"/>
Height: MID 2	Gear Diff: <input type="checkbox"/>
Notes:	MEDIUM
Slipper Clutch:	
Type:	STD PLATES LCF PADS
# of Pads:	2

Shocks:

	Front	Rear
Piston:	1.6 TMG	1.7 TMG
Fluid:	35 AE	30 AE
Spring:	RED KIT	WHITE V2
Limiters:	NONE	NONE
Stroke:	21.25MM	27MM
Eyelet Length:	SHORT	LONG
Cup Offset:	5MM	5MM
Notes:		

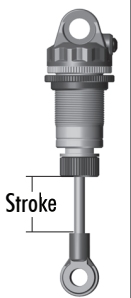

Track Info:

Size:	Small <input type="checkbox"/> Medium <input checked="" type="checkbox"/> Large <input checked="" type="checkbox"/> Extra Large <input type="checkbox"/>
Surface:	Dirt <input type="checkbox"/> Carpet <input type="checkbox"/> Astroturf <input checked="" type="checkbox"/> Multi Surface <input type="checkbox"/>
Traction:	Low <input type="checkbox"/> Medium <input checked="" type="checkbox"/> High <input type="checkbox"/> Very High <input type="checkbox"/>
Moisture:	Dry <input checked="" type="checkbox"/> Damp <input type="checkbox"/> Wet <input type="checkbox"/>
Condition:	Indoor <input type="checkbox"/> Outdoor <input checked="" type="checkbox"/> Dusty <input type="checkbox"/> Hard Packed <input type="checkbox"/> Bumpy <input type="checkbox"/> Grooved <input type="checkbox"/> Smooth <input type="checkbox"/> Loamy <input type="checkbox"/>
Temperature:	Ambient: Track:
Notes:	

Tires:

Front Tires:	SCHU STAGGER
Front Compound:	YELLOW
Front Insert:	NONE
Rear Tires:	SCHU DART
Rear Compound:	YELLOW
Rear Insert:	SCHU MEDIUM BLUE
Wheel (F/R):	SLIM FRONT STD REAR
Notes:	

Body, Wing, Weight:

Body:	B6.1 STD WEIGHT
Wing:	PROLINE TRIFECTA CUT LOW
Wing Angle:	0° <input type="checkbox"/> 3° <input type="checkbox"/> 6° <input checked="" type="checkbox"/>
Servo Weights:	None <input type="checkbox"/> Aluminum <input type="checkbox"/> Steel <input checked="" type="checkbox"/> Other <input type="checkbox"/>
Electronic Weights:	None <input type="checkbox"/> Aluminum <input type="checkbox"/> Steel <input checked="" type="checkbox"/> Other <input type="checkbox"/>
Total Vehicle Weight:	

Vehicle Comments:

Notes: CAR IS EASY TO DRIVE, PLENTY OF FORWARDS TRACTION, Thanks to Roger Mills for the Guidance