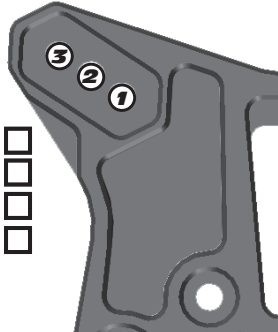

**Front Suspension**
**Steering System:**
**Swing Rack**  **Bellcrank Rack** 
**Anti Roll Bar:**

 2.2mm Green   
 2.3mm White   
 2.4mm Blue   
 2.5mm Yellow 
**Bumpsteer Washers:** \_\_\_\_\_

**Camber:** \_\_\_\_\_

**Caster:** \_\_\_\_\_

**Toe:** \_\_\_\_\_

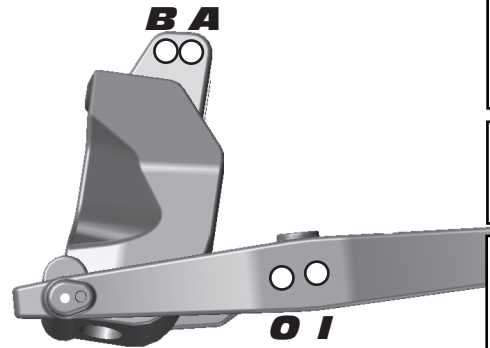
**Upper Hinge Pin Bushing**
**Front #** \_\_\_\_\_  
 Up  Down 
**Rear #** \_\_\_\_\_  
 Up  Down 
**B-Plate Type**

 Low  Original 
**Kickup Bushing A-Plate**
**#** \_\_\_\_\_  
 Up  Down 

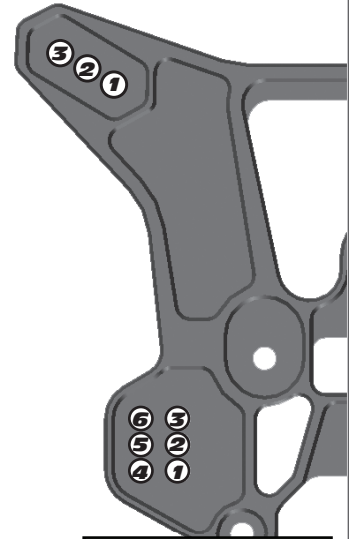
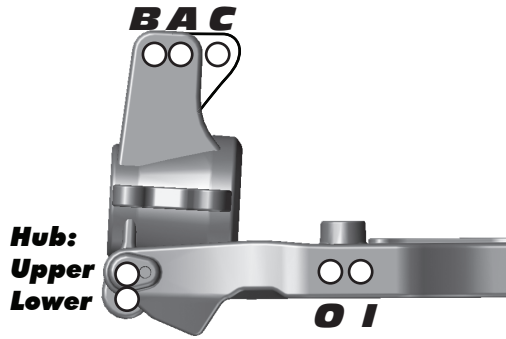
**Ride Height:** \_\_\_\_\_

**Rear Suspension**
**Wheelbase:**
**Long**   
**Medium**   
**Short** 
**Anti Roll Bar:**

 2.5mm Green   
 2.6mm White   
 2.7mm Blue   
 2.8mm Yellow 
**Camber:** \_\_\_\_\_

**Toe Bushing D-Plate**
**#** \_\_\_\_\_  
 In  Out 
**Squat Bushing C-Plate**
**#** \_\_\_\_\_  
 Up  Down 

**Hub:**  
 Upper   
 Lower 
**Ride Height:** \_\_\_\_\_

**Front Shocks**
**Spring:** \_\_\_\_\_ **Shock Cap:** \_\_\_\_\_  
**Shock Fluid:** \_\_\_\_\_ **Length:** \_\_\_\_\_  
**Piston:** \_\_\_\_\_ **Rebound:** \_\_\_\_\_

**Rear Shocks**
**Spring:** \_\_\_\_\_ **Shock Cap:** \_\_\_\_\_  
**Shock Fluid:** \_\_\_\_\_ **Length:** \_\_\_\_\_  
**Piston:** \_\_\_\_\_ **Rebound:** \_\_\_\_\_

**Chassis Braces / Wheel Hex**
**Chassis Braces:**  
**Pivot**   
**Molded**   
**Aluminum** 
**Wheel Hex:**  
**Standard**   
**Narrow** 
**Chassis Weight**
**Weight:** \_\_\_\_\_  
 \_\_\_\_\_  
 \_\_\_\_\_

**Rear Hubs**
**Rear Hubs:**  
**Standard**   
**CNC FT Alum.** 
**Differentials**
**Front Diff Fluid:** \_\_\_\_\_  
**Center Diff Fluid:** \_\_\_\_\_  
**Rear Diff Fluid:** \_\_\_\_\_

**Body / Wing**
**Body Type:** \_\_\_\_\_  
**Wing Type:** \_\_\_\_\_  
**Gap to Tower (MM):** \_\_\_\_\_

**Gearing / Clutch**
**Spur Gear:** \_\_\_\_\_  
**Clutch Bell:** \_\_\_\_\_  
**Clutch Shoes:** \_\_\_\_\_  
**Clutch Spring:** \_\_\_\_\_

**Engine**
**Engine:** \_\_\_\_\_  
**Restrictor:** \_\_\_\_\_ **Temp:** \_\_\_\_\_  
**Muffler:** \_\_\_\_\_  
**Glow Plug:** \_\_\_\_\_ **Fuel:** \_\_\_\_\_

**Tires**
**Tire (F/R):** \_\_\_\_\_ / \_\_\_\_\_  
**Compound (F/R):** \_\_\_\_\_ / \_\_\_\_\_  
**Inserts (F/R):** \_\_\_\_\_ / \_\_\_\_\_  
**Wheel (F/R):** \_\_\_\_\_ / \_\_\_\_\_  
**Notes:** \_\_\_\_\_

**Radio / Servos**
**Radio:** \_\_\_\_\_ **Brake Bias:** \_\_\_\_\_  
**Throttle / Steering Servo:** \_\_\_\_\_ / \_\_\_\_\_  
**Throttle / Brake expo:** \_\_\_\_\_ / \_\_\_\_\_  
**Steering expo:** \_\_\_\_\_  
**Dual Rate:** \_\_\_\_\_

**Race and Vehicle Comments**
**Qualify:** \_\_\_\_\_ **Main:** \_\_\_\_\_ **Finish:** \_\_\_\_\_ **TQ:** \_\_\_\_\_  
**Comments:** \_\_\_\_\_  
 \_\_\_\_\_  
 \_\_\_\_\_

**Track Info**
**Traction:** **High**  **Medium**  **Low**   
**Surface:** **Smooth**  **Bumpy**  **Blue Groove**   
**Soft Dirt**  **Grass**  **Clay**  **Wet**   
**Astroturf**  **Dusty**  **Other:** \_\_\_\_\_